

YINKA
ILORI x **Dunelm**

Yinka
Dining Table
Assembly & Care Instructions

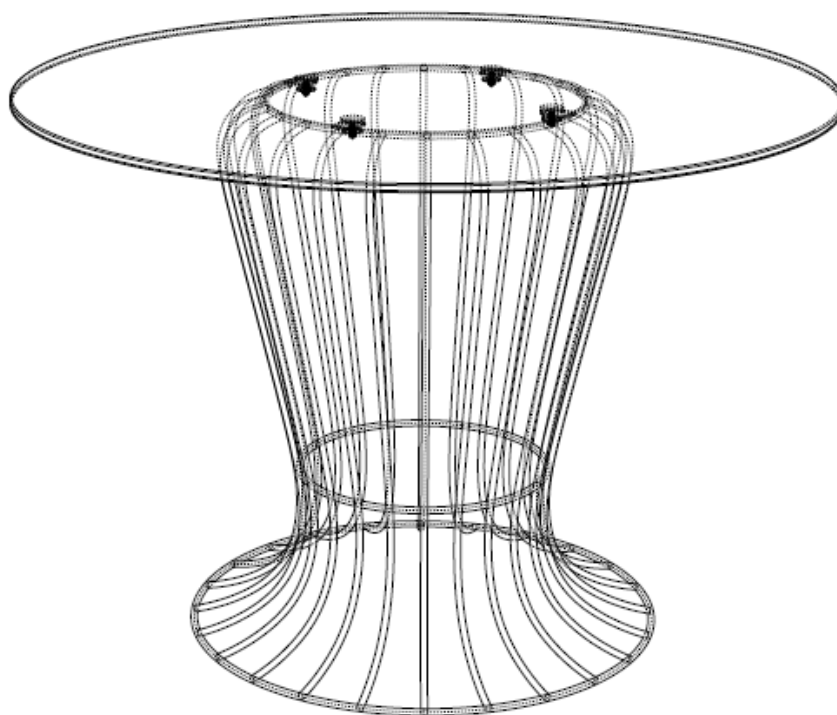





Dunelm
www.dunelm.com

Safety advice.

Dear Customer

- **IMPORTANT** – The first step you need to take is to ensure your safety! Please take the time to read and understand these instructions before assembling the product.
- Please keep these instructions for future reference.
- This item is intended for indoor use only – unless otherwise specified. Avoid exposure to humid conditions.
- Assembly to be carried out by a competent adult only.
- During assembly children should be kept away from the product due to possible risk of injury. The product may contain small parts that could also cause choking if swallowed.
- Products can be dangerous if incorrectly installed or assembled. Assembly should be carried out by a competent person and instructions followed. No liability will be accepted for damage or injury caused by incorrectly installed or assembled products.
- Never use an electric drill to assemble a product, as this can cause damage to parts.
- Regularly check all fastenings to ensure that they are properly tightened.
- Restrain children from climbing or playing on or around the product. Always consider where products are positioned to ensure children cannot get access to long cords or windows.
- Some products will be supplied with anti – tip kits which should always be used to secure the product to the wall and prevent tipping.
- Keep all plastic wrapping materials away from babies and children to avoid danger of suffocation.
- Ensure that all packaging is disposed of carefully and responsibly. Please recycle where possible.
- Once items are part or fully assembled, they are not returnable unless faulty.
- Check all parts are intact and undamaged. Any issues please contact our customer service team.
- Some products will be supplied with anti – tip kits which should always be used to secure the product to the wall and prevent tipping.

Max weight limit	No. of people to assemble	Assembly difficulty	Time to assemble
			
25 KG	2 recommended	Easy	<30 minutes

Parts supplied.

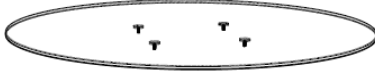
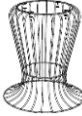
Ref	Part	Visual	Qty
1	TOP		1
2	BASE		1

Ref	Hardware & dimension (mm)	Qty
A	Dome Nut 6 x 10mm	4
B	Washer 7 x 20mm	4

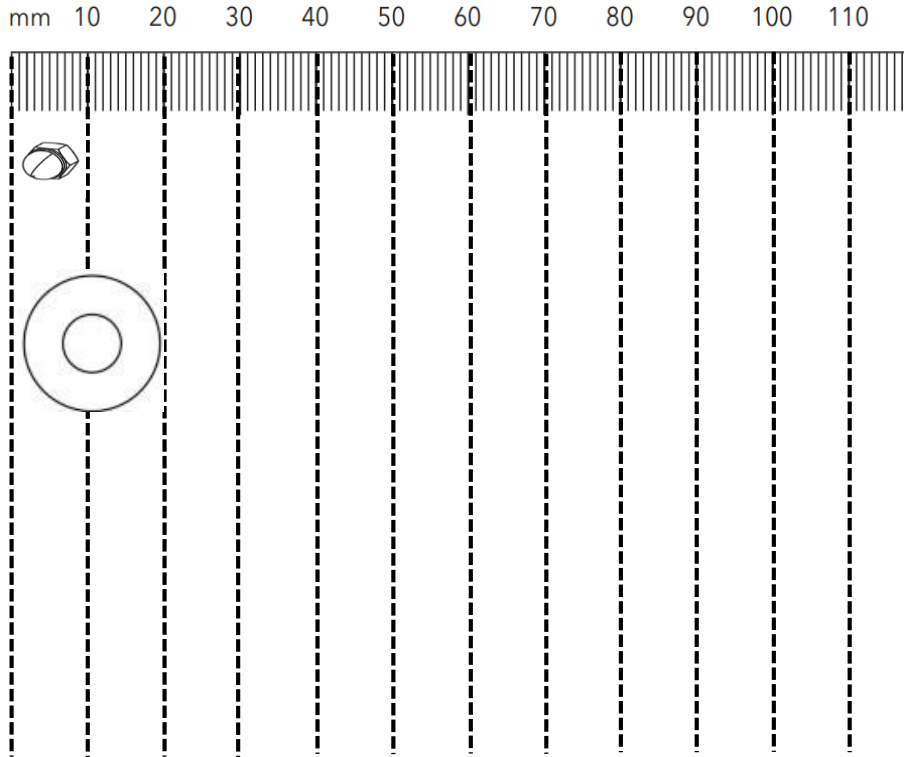

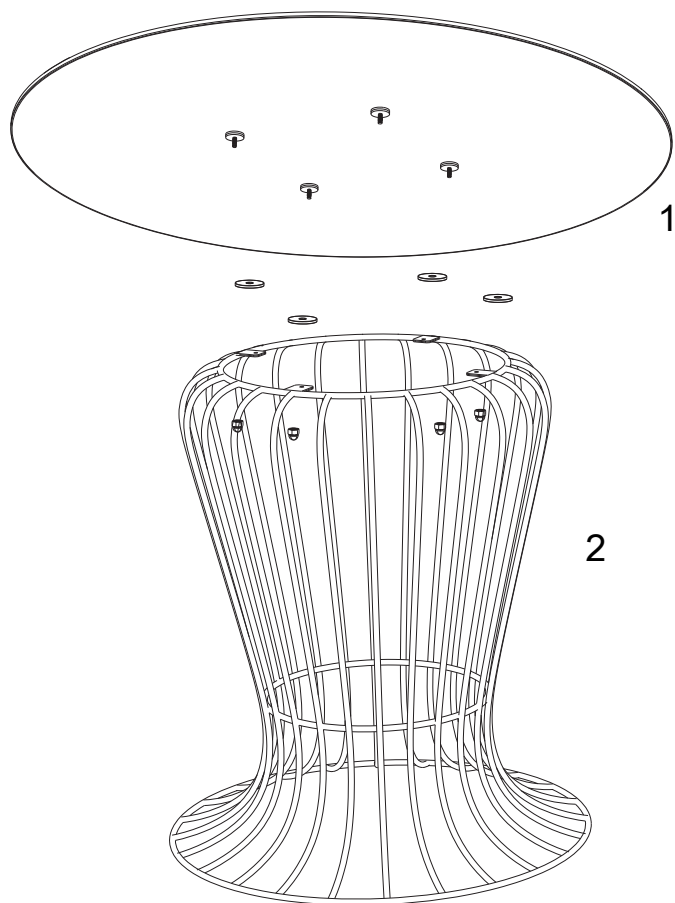

	<p>ALWAYS lay each panel down on a clean and level area, ideally in the room of intended use, ensuring there is enough room to maneuver around the item.</p>
	<p>NEVER pull furniture into place as this causes damage to the internal structure and feet fixings. Always lift to move.</p>
	<p>NEVER flip your upholstery allowing corners to hit the floor as structural damage can be caused. Always turn gently.</p>

1

1	2		
---	---	--	--

2

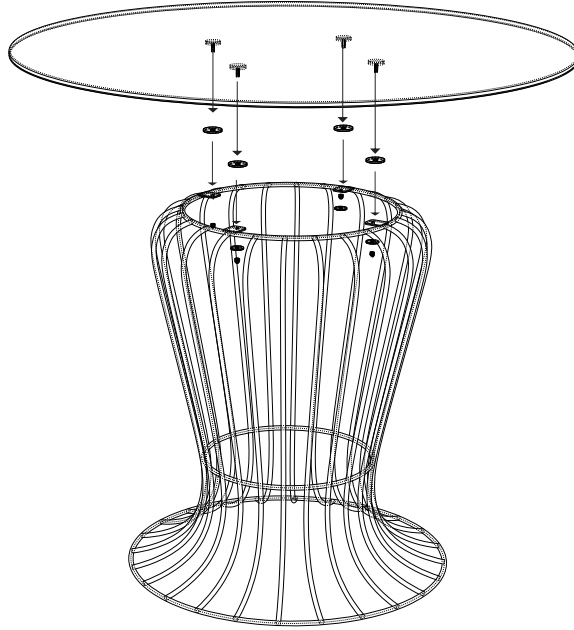

1	2	B X 4		
---	---	-------	--	--

3

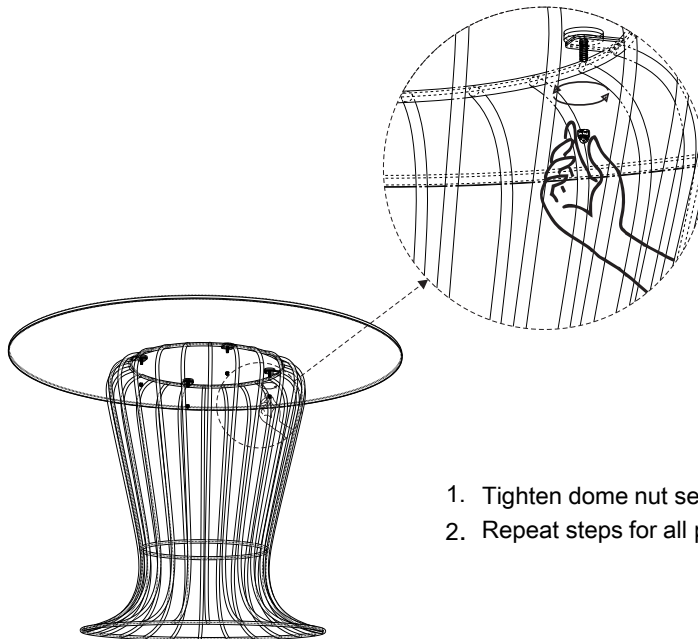

1. Tighten dome nut securely between metal pipes
2. Repeat steps for all parts

1	2	A X 4		
---	---	-------	--	--

4

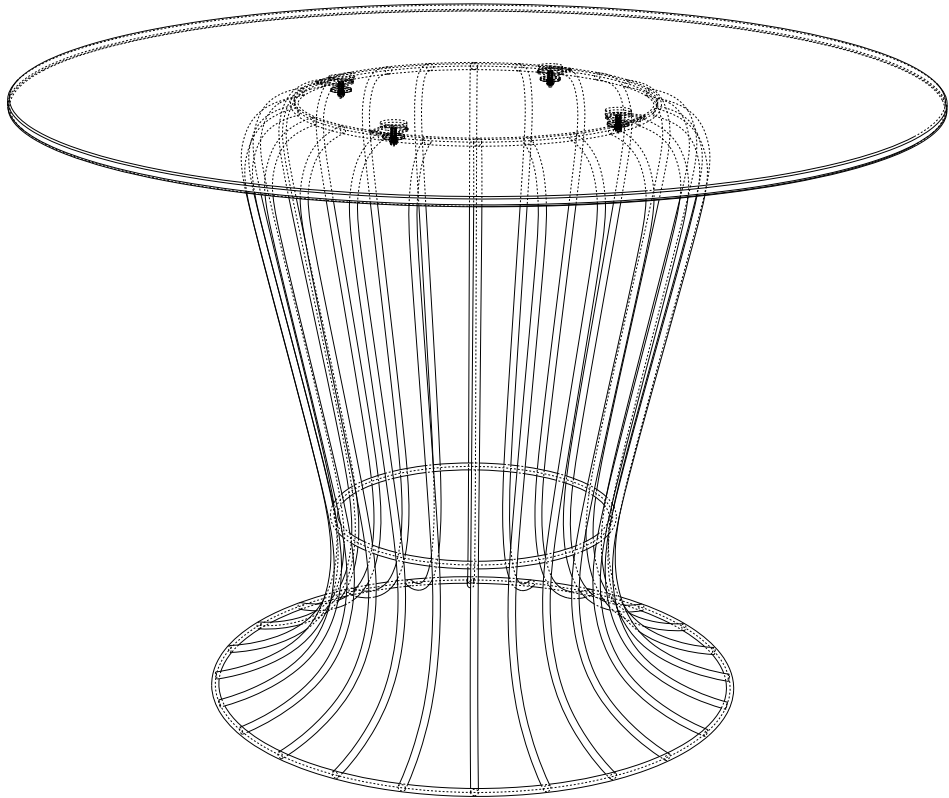

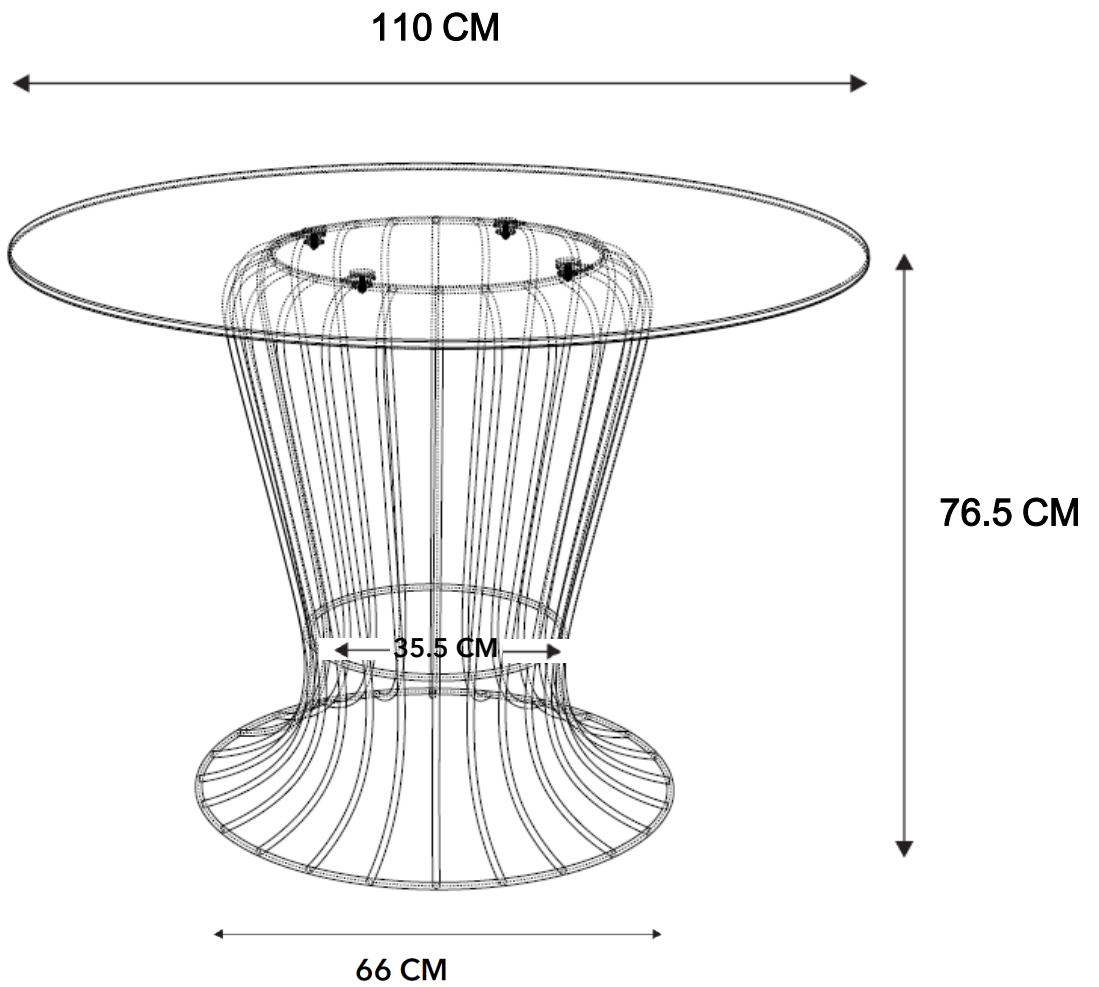

-
- Uneven floors could give the impression that doors are out of alignment or that the furniture is wobbly. Be aware of this and compensate, if necessary, by adjusting the hinges or packing a corner to level the item. Please refer to the assembly instructions and adjust accordingly.
 - If your furniture becomes stained, scratched, chipped or suffers other damage, we recommend professional help is sought to restore it. Please contact our customer services line for recommended agents.
 - **DO** move items such as ornaments or coasters around periodically to allow the colour to mellow evenly.
 - **DO** use mats and coasters to protect the surface from heat, liquids, or items that may cause scratches.
 - **DO** ensure plastic or felt feet protectors are securely fitted into place on the feet and legs to avoid scratches.
 - **DO** check fittings and fixings from time-to-time and tighten when necessary. Stop using the product if still unstable after all screws and bolts are tightened.
 - **DO NOT** drag your furniture when moving it as this can damage joints. Always lift furniture into place.

Glass & Mirror Care

- Mirrors are a potential fire hazard. Keep out of direct sunlight.
- Handle with care.
- Always supervise young children around glass products.
- If the glass is chipped or broken, stop using the product.
- It is not recommended that glass or mirrored items to be positioned over heat sources such as radiators.
- **DO** clean your item, using a soft cloth slightly dampened with water and wipe clean. Then buff with a dry clean cloth. Use washing up liquid if necessary.
- **DO** only use fixings provided with the product.
- **DO** stop using the product if the glass is chipped or broken.
- **DO NOT** place very hot or very cold items directly on glass surfaces. Adequate table mats can be used to prevent such items coming into direct contact with the furniture.
- **DO NOT** sit or stand on glass surfaces.
- **DO NOT** use glass as a chopping board.
- **DO NOT** strike the glass with hard or pointed items or use the glass as a chopping surface.
- **DO NOT** use abrasives cleaning agents, as these may scratch the glass.
- **DO NOT** install this product in a damp environment such as a bathroom or outside, unless the product specifies otherwise, as this may cause the product to warp and become damaged.

Metal Care

- Ensure that mats are placed to prevent hot items coming into contact with the surface.
- **DO** use a clean, dry cloth to dust the surface.
- **DO** use a clean cloth with soapy water to clean stubborn marks, using dry cloth afterwards to remove any smears.
- **DO NOT** use abrasive cleaners or cloths as these can scratch the surface of the metal.
- **DO NOT** use chemical cleaners or polishes on any metal.

If you have any issues with this product, you can call our Customer Service team on:
0345 165 6565 Monday to Friday **9am to 5:00pm.**

Alternatively, you can contact our team by Live Chat on: **Dunelm.com**
Monday to Friday 8am – 8:30pm
Saturdays 8am – 5:30pm
Sundays and bank holidays 9am – 4:30pm.



Dunelm (Soft Furnishings) Ltd. LE7 1AD
& Dunelm (Soft Furnishings) Holdings
Ltd. Dublin D12 WR25.