

# 10 Piece Dining Set Black

## INSTRUCTIONS

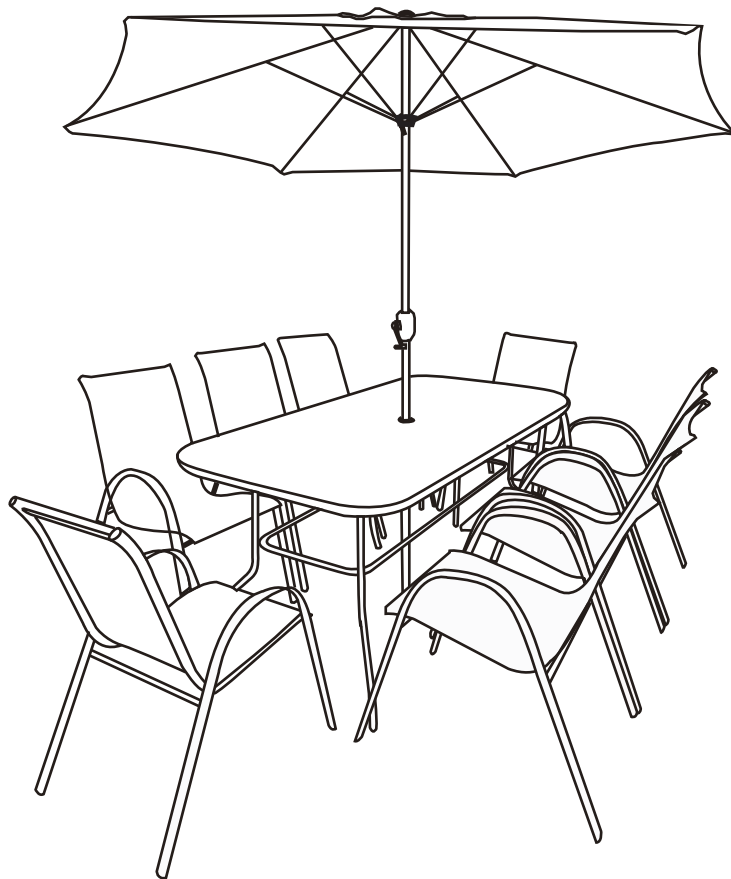

**Dunelm**

[www.dunelm.com](http://www.dunelm.com)

---

# Thank you

---

## Dear Customer

Thank you for purchasing your new piece of furniture from Dunelm. We put a lot of effort in the design and construction of our products to ensure they set the standard for quality, durability and ease of assembly.

If for any reason you feel we haven't lived up to the high standards we set ourselves, please don't hesitate in contacting us on **03451 656565** where our team will be very keen to understand what has gone wrong and, more importantly, put it right.

## The next step...

There is no need to feel daunted by the number of parts and fittings in front of you, we have compiled this straightforward, step-by-step guide to make sure that assembling your furniture is as easy as 1, 2, 3. Before you begin, we advise that you check that you have everything you need to get started.

## Top tip

Find a space to spread everything out across the floor before you begin assembling the item. Lay each panel down on a clean and level area, ideally in the outside of intended use, ensuring there is enough room to manoeuvre around the item. It is recommended that two people assemble this product together. The full list of furniture parts, fixtures and fittings, as well as the tools you will need for assembly can be found in this manual.

## Top tip

Identify all of the fittings, make sure that you have them all prepared and familiarise yourself with each component, to make things easier when you are putting it all together.

## Safety and care advice

**IMPORTANT** - The first step you need to take is to ensure your safety! Please take the time to read and understand these instructions before assembling your furniture.

Please keep these instructions for future reference.

Keep children and animals away from the assembly area. This furniture contains small parts that could cause choking if swallowed.

Keep all plastic wrapping materials away from babies and children to avoid danger of suffocation.

Ensure that all packaging is disposed of carefully and responsibly.

From time to time check that there are no loose fittings on the unit, re-tighten when necessary.



Two people may be required for the assembly of this product.

Once items are part or fully assembled they are not returnable unless faulty.

Some items will be supplied with a wall fixing strap, which we recommend is used to secure the item to the wall, to prevent a child from accidentally pulling furniture over. Furniture can be dangerous if incorrectly installed. Assembly should be carried out by a competent person. No liability will be accepted for damage or injury caused by incorrectly installed or assembled furniture.



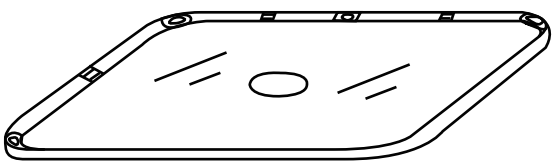

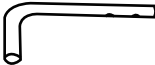
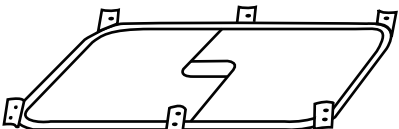
## Component parts supplied for Table

### BOX 1/3

Ref	Dimension	Visual	Qty
1	180*90*3.5CM		1
2	N/A		4
3	N/A		2
4	N/A		1

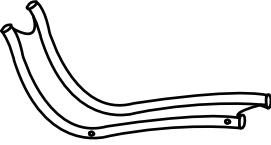
## Component parts supplied for Chair

### BOX 2/3

Ref	Dimension	Visual	Qty
1	N/A		8
2	N/A		8
3	N/A		16
4	N/A		16

## Component parts supplied for Parasol

### BOX 3/3



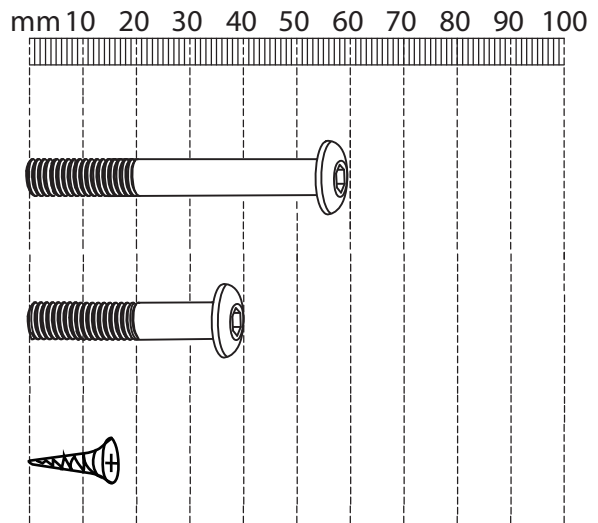

# Parts and fittings for Table

Fixtures and fittings  
supplied (actual size)

Ref	Dimension	Qty
A	M6*55mm	6
B	M6*35mm	6
C	4*14mm	6

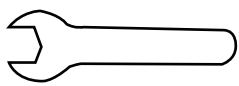

Fixtures and fittings  
supplied (not to scale)

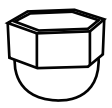
Ref	Dimension	Visual	Qty
D	N/A		1
E	N/A		1
F	N/A		6
G	N/A		12
H	N/A	 M6	12
I	N/A		12

# Parts and fittings for chair



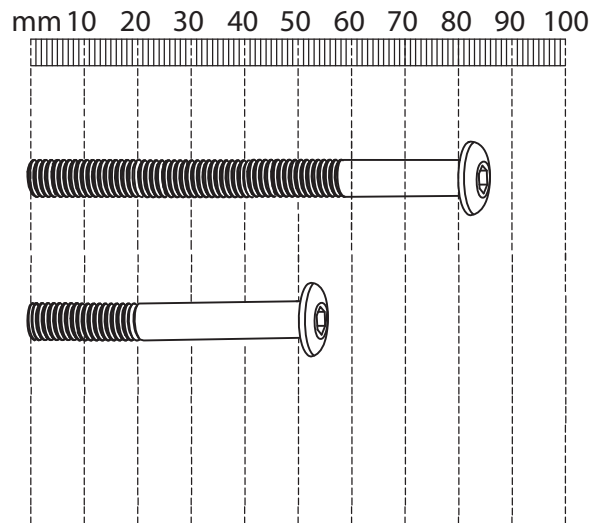

Extra pcs is only for spare.

Fixtures and fittings  
supplied (actual size)

Ref	Dimension	Qty
A	M6*80mm	32
B	M6*50mm	32

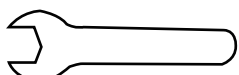

Fixtures and fittings  
supplied (not to scale)

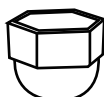
Ref	Dimension	Visual	Qty
C	N/A		1
D	N/A		1
E	N/A		64
F	N/A	 M6	64
G	N/A		32
H	N/A		64

---

## Exploded view for table

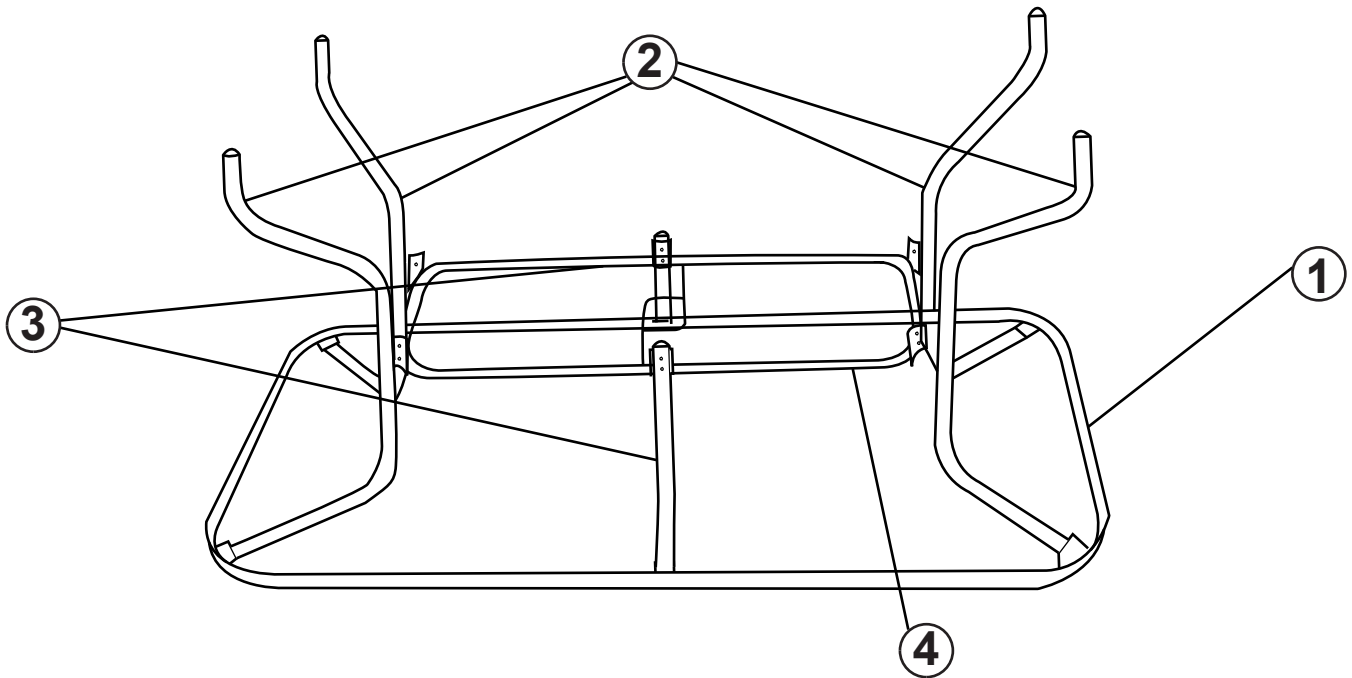

## Exploded view for chair

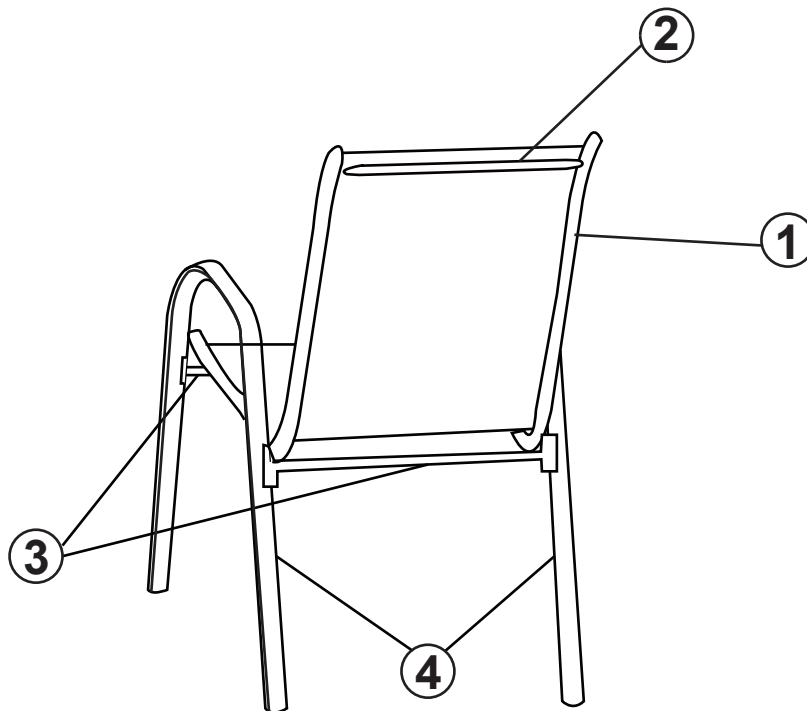

Do not tighten bolts until fully assembled.

**Step 1:**

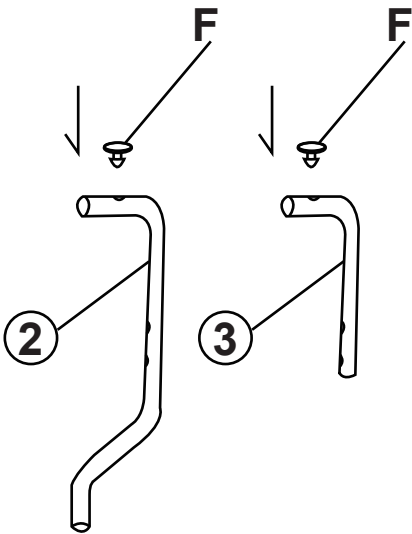

**Step 2:**

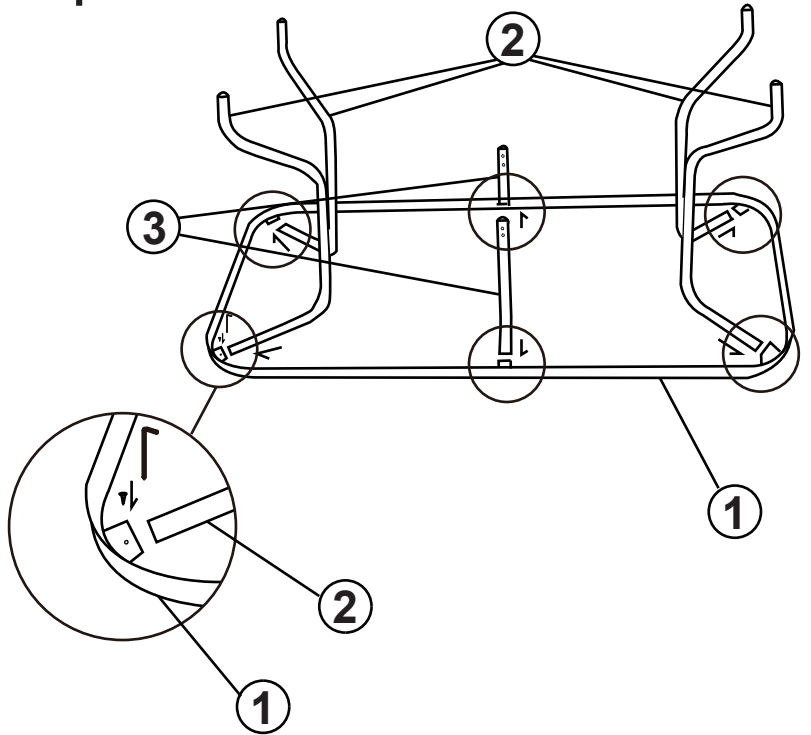

**Step 3:**

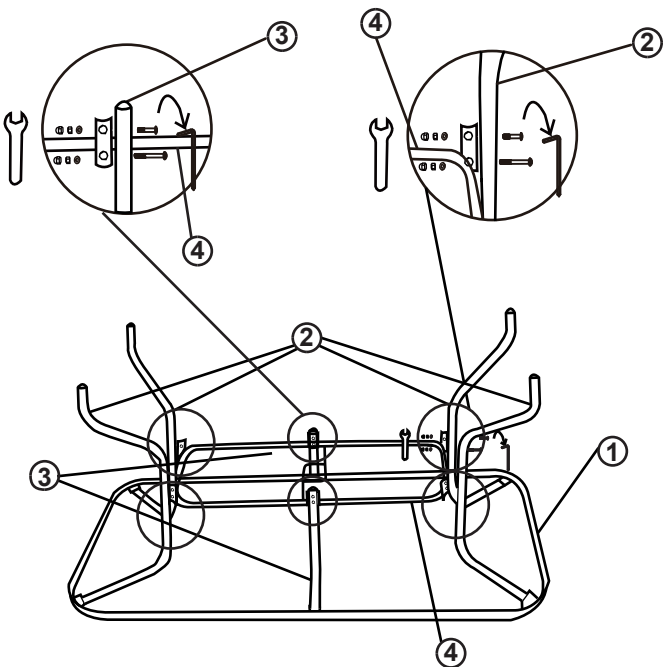

**Step 4:**

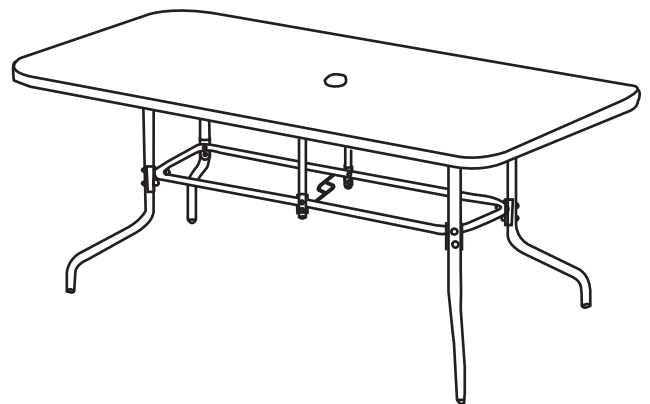

**Warnings:**

1. Always use a parasol with a suitable weighted parasol base.
2. Do not remove the parasol cut-out protector as this prevents direct contact between the glass and the parasol.

# Do not tighten bolts until fully assembled.

## Step 1:

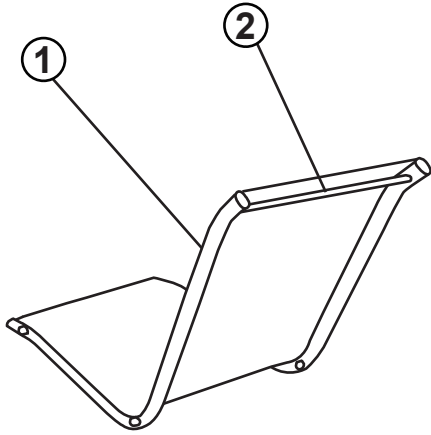

When fixing the back bar, it can be easier to put the chair on table, or put one side of chair on the ground. Fix one side first, then stretch the textilene fabric, enter one corner of the other side, then overturn this side of chair tube to get the hole in.

## Step 2:

Only tighten the below 4 bolts.

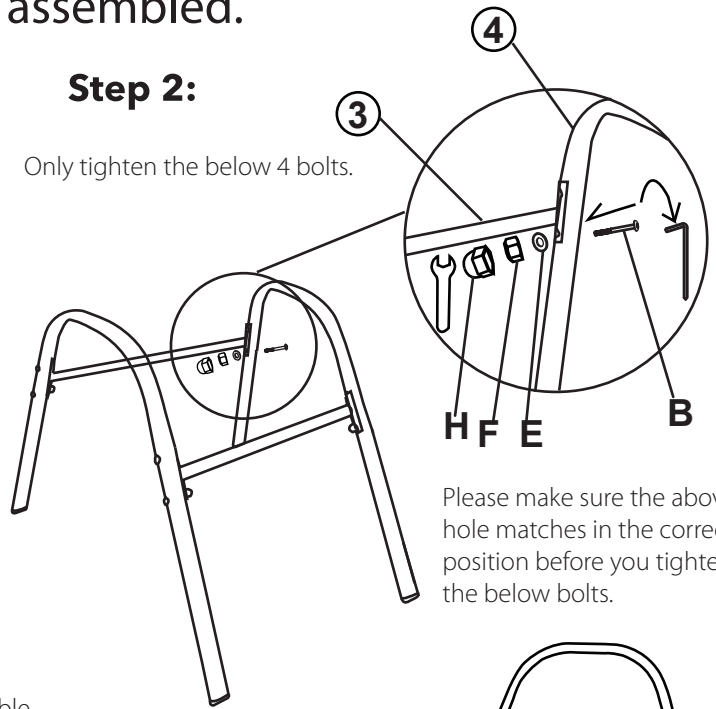

Please make sure the above hole matches in the correct position before you tighten the below bolts.

## NOTICE:

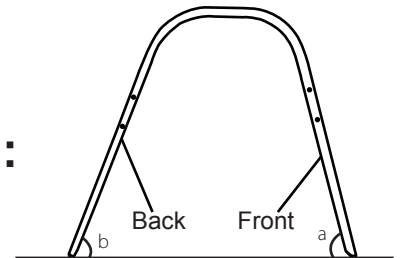

Put the 2 legs flat on the ground, you will see that the angle of 'A' is larger than the angle of 'B'. The back leg is more sloped than the front leg.

## Step 3:

Put the chair on the 2 bars, with the front or back facing towards you. Fix one side to the legs first, with the bolts very loose, this will allow you to stretch the textilene fabric across to the other side.

Fix in the other side, and then alternately tighten each side until the Textilene is taught.

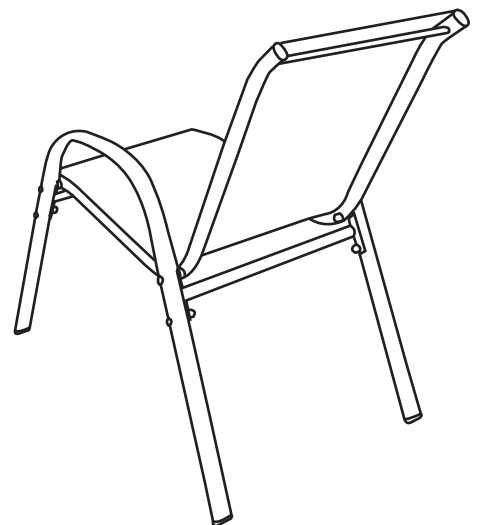
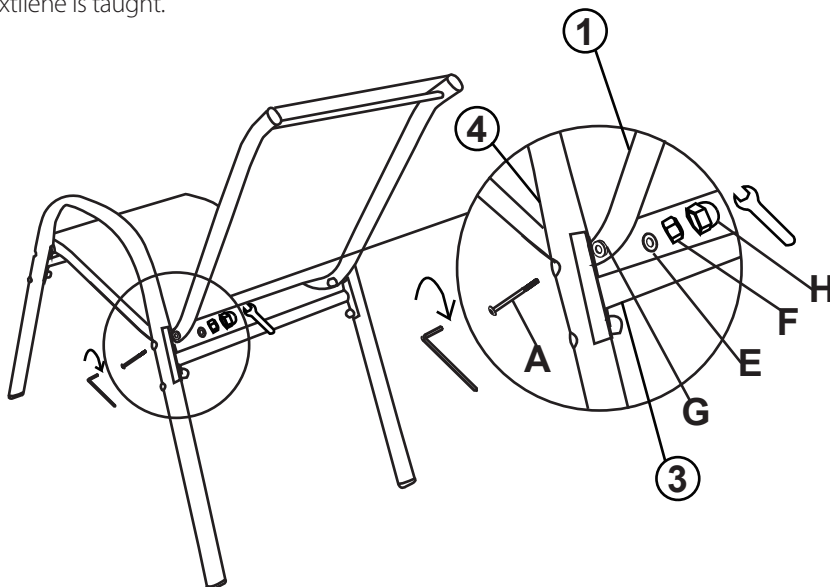

When fixing the seat to the other side of the legs, it can be easier to put the chair in a higher place, or lay the chair on the ground so you can see the fixings and stretch the textilene more easily.



---

# GARDEN FURNITURE CARE GUIDE

---

## General Care Advice:

We recommend that you use a breathable cover for garden furniture when not in use and during the winter it should ideally be stored inside in a cool place with an airflow.

During bad weather and winter months the products should be stored in a dry place to avoid rusting.

Parasols should be left open to dry if they get wet and should always be taken down and put away in windy weather.

If you are placing furniture against a wall, leave a gap of at least 25mm to increase air flow around the product.

Always lift your furniture into place, avoid dragging it across the floor as this can cause damage to joints.

Avoid rocking backwards on two legs of chairs as this will weaken the joints.

Do not use a pressure washer or jet wash on any of your garden furniture.

Periodically, check the tightness of fixings and tighten if necessary.

## Outdoor Cushions Care Advice:

All reversible cushions should be turned daily, and their positions switched, this will help prevent excessive soiling and ensure wear-out is even.

It is essential that all fibre cushions are given a vigorous plumping by shaking and squeezing to redistribute the fibre on a daily basis. This will add air into the fibres to ensure that they perform to the best of their ability and prevent the fibre going flat and lumpy.

Where possible, keep upholstery out of direct sunlight to avoid discolouring and fibre weakening. Garden furniture covers will fade slightly over time if left out in the sun for prolonged periods.

Avoid sharp items such as toys, jean rivets and buckles coming into contact with the upholstery as these can easily snag, tear or pull the fabric.

When not in use, we recommend you store furniture cushions indoors, rather than leaving them outside, as this will prolong their life.

Do not leave cushions out in the rain, if these do become wet, please be aware that the fillings inside may take longer to dry out.

## For Accidental Spills or Stains:

Don't rub or scrub with a cloth as this could damage the fabric and remove the colour. Blot or soak up spills instead.

Don't use washing up liquid, detergents or bleach to remove stains from fabric.

Don't soak or allow fabric to become wet, be aware that the filling of the cushion will take longer to dry than the fabric.

Do not machine wash fabric cushion covers.

## **Glass Outdoor Furniture Care Advice:**

Do not use glass as a chopping board.

Do not use very hot or very cold items on the glass unless adequate table mats are used to prevent such items coming into direct contact with the furniture.

Do not strike the glass with hard or pointed items.

Do not use abrasive cleaners on the glass as these may scratch and damage the glass.

To clean your item, please use a soft cloth slightly dampened with water and wipe clean. Then buff with a dry clean cloth. Use washing up liquid if necessary.

If the glass is chipped or broken, stop using the product and consult Dunelm.

## **Metal Outdoor Furniture Care Advice:**

Use a clean, dry cloth to dust the surface.

If there are stubborn marks use soapy water and a clean cloth, ensure that the water does not touch any other parts of the product. Afterwards use clean, dry cloth to remove any smears.

Do not use abrasive cleaners or cloths as these can scratch the surface of the metal.

Do not use chemical cleaners or polishes on any metal.

Ensure that mats are placed to prevent hot items coming into contact with the surface.

Do not put the chairs upside down on a glass table when not in use or on rainy day.

## **Wooden Outdoor Furniture Care Advice:**

Try to avoid the wood getting too wet by placing a cover over your furniture when it rains.

Wood is a natural product, and each piece is individual. The colour will mellow over time and new items can vary in shade from items that you have already purchased.

Always use mats and coasters to protect the surface when placing items on the furniture. This will help to protect the finish from heat, liquids or items that might scratch your furniture.

Only clean using a damp cloth or sponge and mild detergent or washing up liquid solution, do not use bleach or abrasive cleaners.

Wood can absorb liquids, for this reason, remove any spills immediately to avoid staining.

If your furniture becomes stained, scratched, chipped or suffers other damage, we recommend professional help is sought to restore it. Please contact our customer services line for recommended agents.



