

Assembly Instructions

You have your fittings in place, and tools at the ready, so let's begin

1. Decide on the position of the light fitting or remove existing light fitting. Note the position of the electrical connections, and ensure there is a solid mounting surface, preferably a wooden joist or joist bridge, to support the weight of the light fitting.
2. Separate the glass shade (1) from the ceiling cover (2) by twisting anticlockwise.
3. Use the ceiling cover as a template to mark the screw holes. Taking care to avoid damaging concealed wires and pipes, drill holes and fit supplied wall plugs (3) (suitable for masonry only - for other surfaces use appropriate fixings).
4. Pierce a hole in the rubber grommet fitted in the ceiling cover and pull the household wiring through (4).
5. Secure the fitting to the ceiling by using the supplied screws and rubber washers (5). Take care not to trap any wiring.
6. Connect the house wiring to the terminal block - see expanded wiring diagram (6). **NOTE: This is a Class 1 fitting and must be connected to earth.**
7. Fit the bulb (7). Max. 15W LED E27 GLS. **NOTE: Never fit bulbs of a higher wattage than those specified on the label (as this may cause overheating and damage the fitting).**
8. Refit the glass shade (8) by aligning the gaps in the thread with the raised points on the inside of the ceiling cover and twisting clockwise. Ensure the rubber seal around the glass shade is in place.
9. Turn on the power and test.

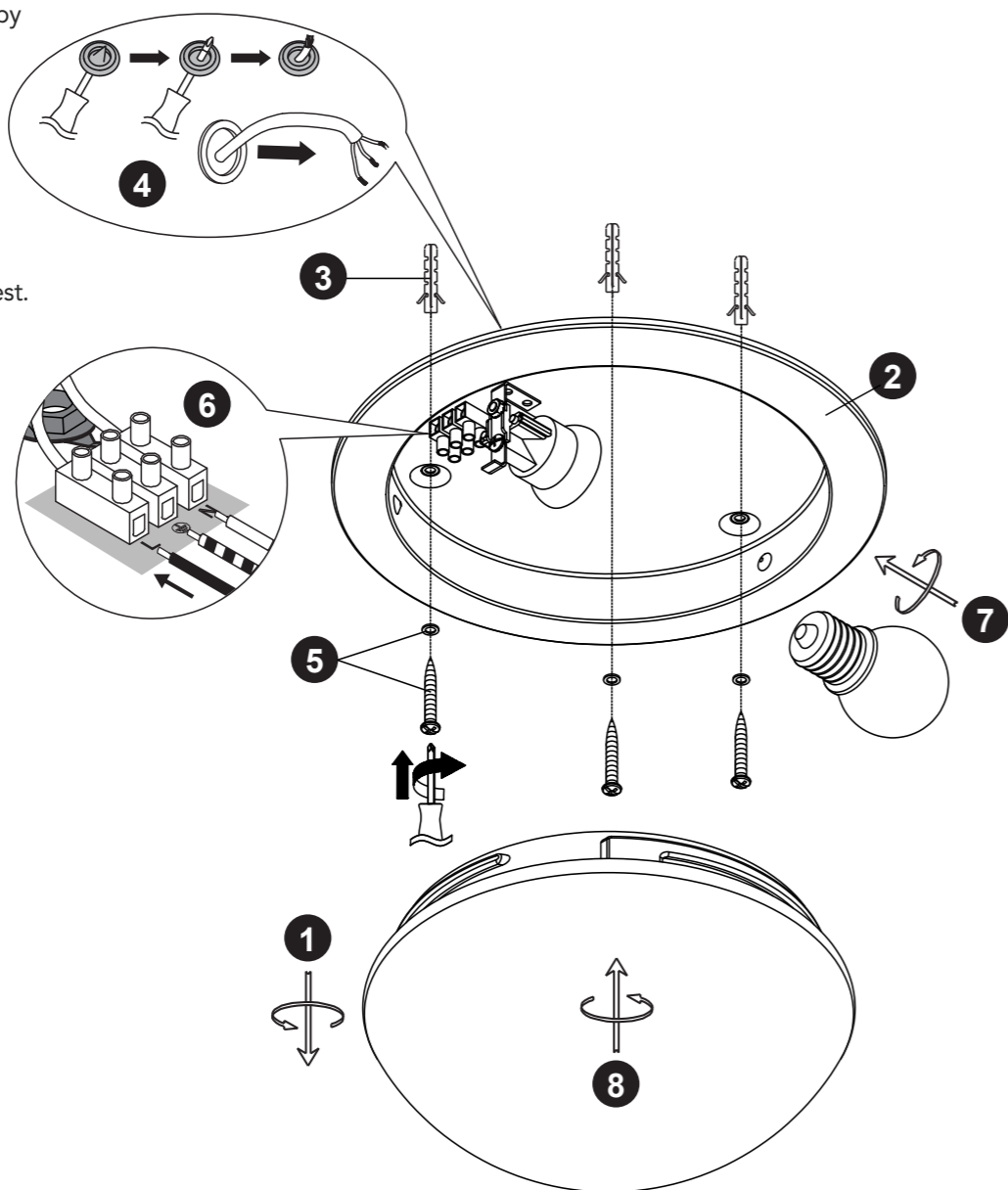

Finally, we hope you enjoy your light for many years to come and thanks again for your purchase.



DEAR CUSTOMER



Thank you for purchasing your new light fitting from Dunelm.

We put a lot of effort into sourcing and supplying great products, so they are:

- Easy to assemble
- Produced using durable, quality materials

If for any reason you are unhappy with this product, please don't hesitate to contact us on **0845 1 65 65 65** where our customer services team will be happy to help.

The next step...

There is no need to feel daunted by the number of parts and fittings in front of you, as we have compiled this straight forward, step-by-step guide to make sure that assembling your fitting is as easy as 1, 2, 3.

Before you begin, we advise that you check that you have everything you need to get started. A full list of components can be found on page 3 of this manual.

TOP TIP

Find a space to lay the fitting and fixtures out before you begin, and familiarise yourself with the parts.

Ready...?

You are nearly ready to begin, but before you do, make sure you take the time to read through and fully understand our SAFETY AND CARE ADVICE detailed on page 2 of this manual.

We hope you enjoy your light for years to come.

The Dunelm Team



Safety and Care Advice

IMPORTANT - The first step you need to take is to ensure your safety! Please take the time to read and understand these instructions before assembling your light, and retain for future reference.

- This product is only suitable for connection to a 240V~50Hz supply in accordance with current IEE wiring regulations. It should be installed in accordance with local building regulations. It is for indoor use only.
- Before installing your light fitting always switch off the mains supply and remove the appropriate fuse or switch off the appropriate circuit breaker before commencing installation.
- This fitting is a Class 1 product, and must be connected to Earth.
- Never fit bulbs of a higher wattage than those specified on the label, as these may cause overheating and damage the fitting.
- This light may be installed in Zone 2 and Outside Zones of a bathroom where water jets are not used for cleaning purposes - See Zone diagram. If installing in a bathroom, a 30mA RCD must be used in accordance with IEE Wiring Regulations and the Building Regulations. An electrician must be consulted if in any doubt about your own competency or meaning of bathroom "Zones", "Equipotential Bonding" or "RCD".
- This product has special protection against the ingress of water, and is rated IP44.
- This product is suitable for use with a dimmer switch, when used with dimmable bulbs.
- If you are in any doubt about your competence please consult a qualified electrician.
- If any modification is made it will invalidate the warranty and may render the product unsafe.
- This product contains delicate parts – be careful during handling and maintenance to avoid breakage.
- Keep children and animals away from the assembly area.
- This fitting contains small parts that could cause choking if swallowed.
- Keep all plastic wrapping materials away from children to avoid danger of suffocation.
- Ensure that all packaging is disposed of carefully and responsibly.

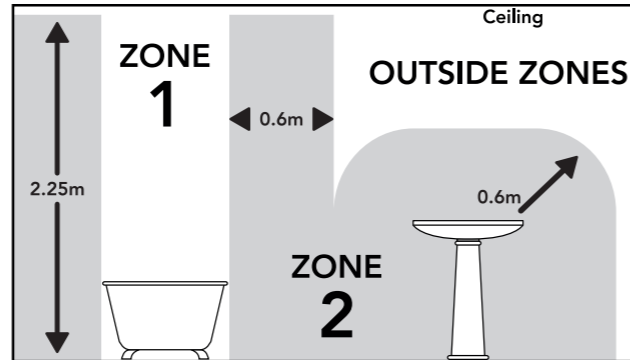

Care and Maintenance Advice

In order to prevent damage or wear to your fitting, take care to ensure the following:

Allow 10 minutes to cool before replacing, adjusting or cleaning.

Clean with a dry cloth only. In order to preserve the finish, do not use liquid or abrasive cleaners on this product.

Glass parts - Remove and wash in warm water or just use a damp cloth. Do not use abrasive materials as these will damage the finish. Take care when handling glass parts to avoid damage or injury.

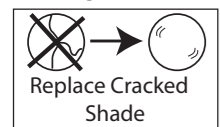

Do not use this product if the shade is cracked or damaged. Do not use the product without the shade attached.

Our packaging is recyclable, please recycle where facilities exist.

Waste electrical products should not be disposed of with household waste. Please recycle where facilities exist. Check with your Local Authority or retailer for recycling advice.

We're happy to recycle your old light for free. Simply bring it to store within 28 days of purchase of your new light, with your receipt, and we'll make sure your old light stays out of landfill.

dunelm.com

Manufactured in China for
Dunelm (Soft Furnishings) Ltd. LE7 1AD
& Dunelm (Soft Furnishings)
Londonderry Ltd. BT48 8QN



03092024 - 30713583_30713584_30921794

Component Parts

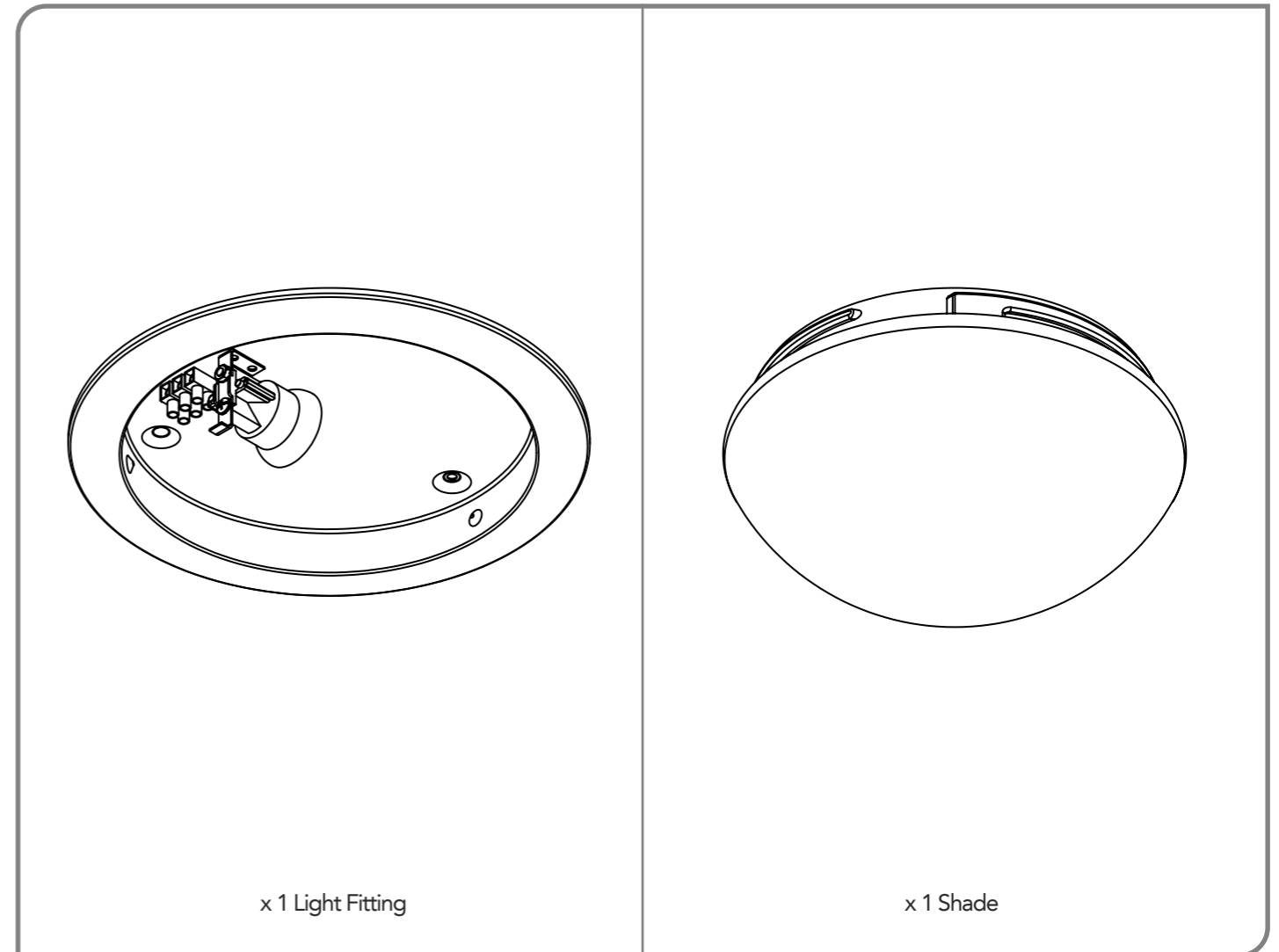

Component Fittings

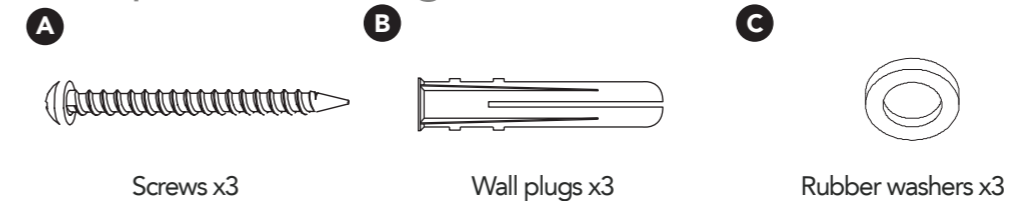

Tools Required

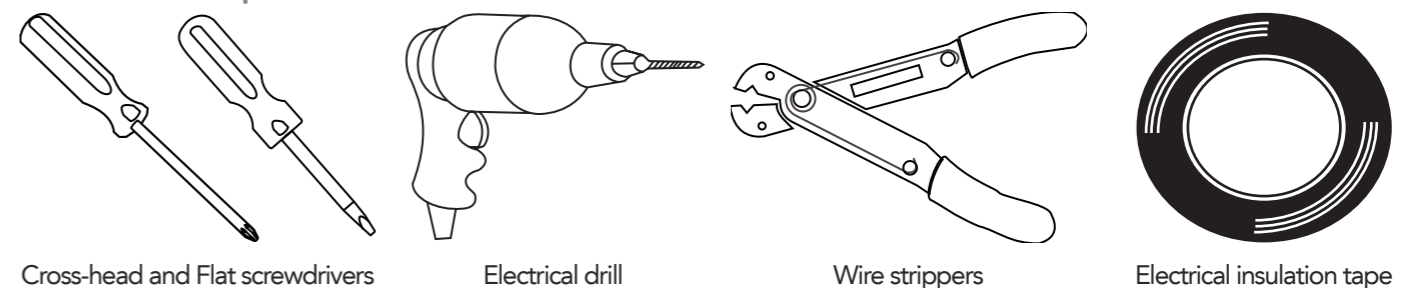

dunelm.com

