

# ASSEMBLY & PRODUCT CARE

4 POSTER 6' BED – 1905 X 2110 X 2000  
5055999243810 / 5055999242837

---

Thank you for purchasing this Bed. Please read the instructions carefully before use to ensure safe and satisfactory operation of this product

---

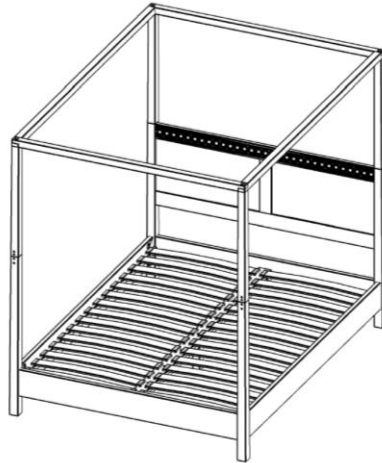

---

## Pre-assembly preparation

Please ensure instructions are read in full before attempting to assemble this product

---

### Necessary Tools

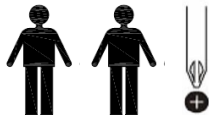

---

Please check the pack contents before attempting to assemble this product. A full checklist of components is given in this leaflet. If any components are missing, please contact the retailer from whom you bought this product.

This product is **HEAVY**, it should be assembled as near as possible to the point of use. **TAKE CARE WHEN LIFTING** to avoid personal injury and (or) damage to the product.  
(Include if relevant)





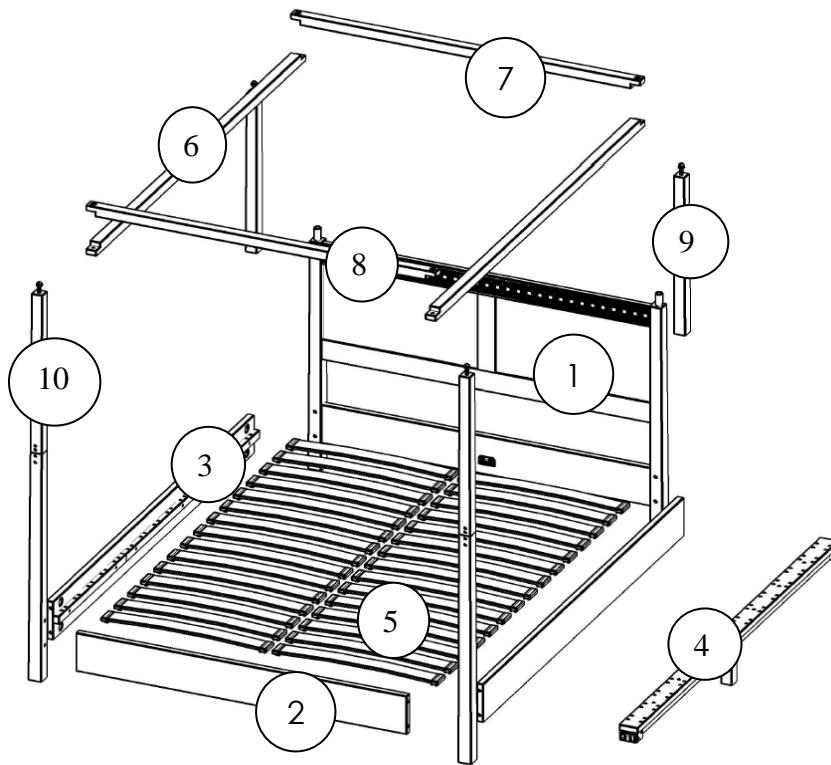

This product takes approximately **45 MINUTES** to assemble with **2 PEOPLE**.

The fittings pack contains **SMALL ITEMS** which should be **KEPT AWAY FROM YOUNG CHILDREN**.

Read this leaflet in full before commencing assembly.

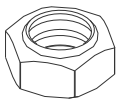
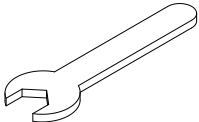
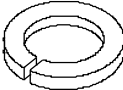
# Fittings and parts checklist



Item	Description	Qty	Item	Description	Qty	Item	Description	Qty
1	Headboard	1	2	Footboard bottom rail	1	3	Side Rail	2
4	Centre rail	1	5	Slats	30	6	Side top rail	2
7	Headboard top rail	1	8	Footboard top rail	1	9	Headboard upper post	2
10	Footboard post	2	11	Plastic socket 	60			
A	Crescent washer 	12	B	Bolt 	12	C	Nut 	12
D	Wrench Key 	2	E	Spring washer 	12	F	Screw+cover 	4
G	Domed Nut 	4	H	Flat washer 	4			

---

## Step by step assembly instructions

---

### Step one

- Screw the Bolt (B) into the holes provided in the footboard post (10) using a screw driver.

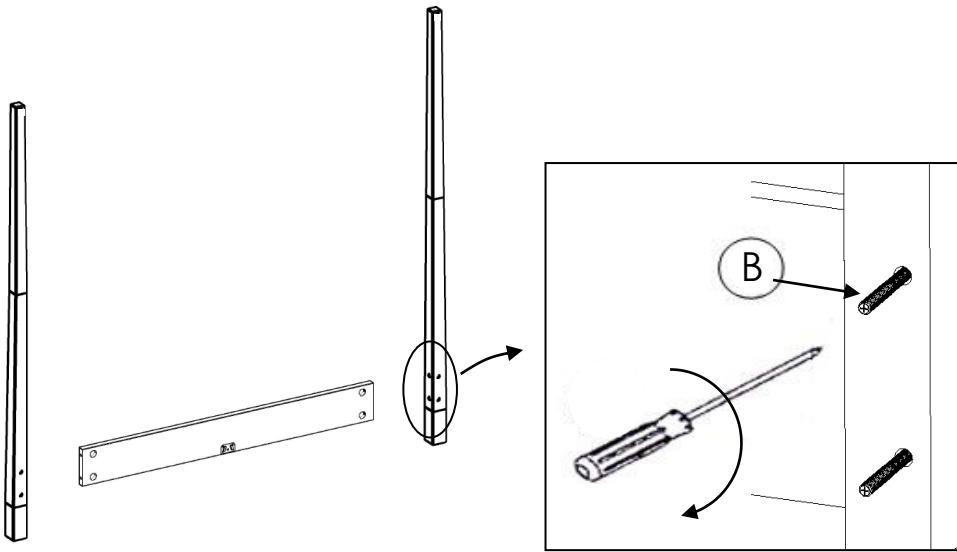

### Step two

- Put the crescent washer (A) and spring washer (E) through the bolt (B). Put the nut (C) on the bolt (B) and tighten the nut with the wrench key (D).

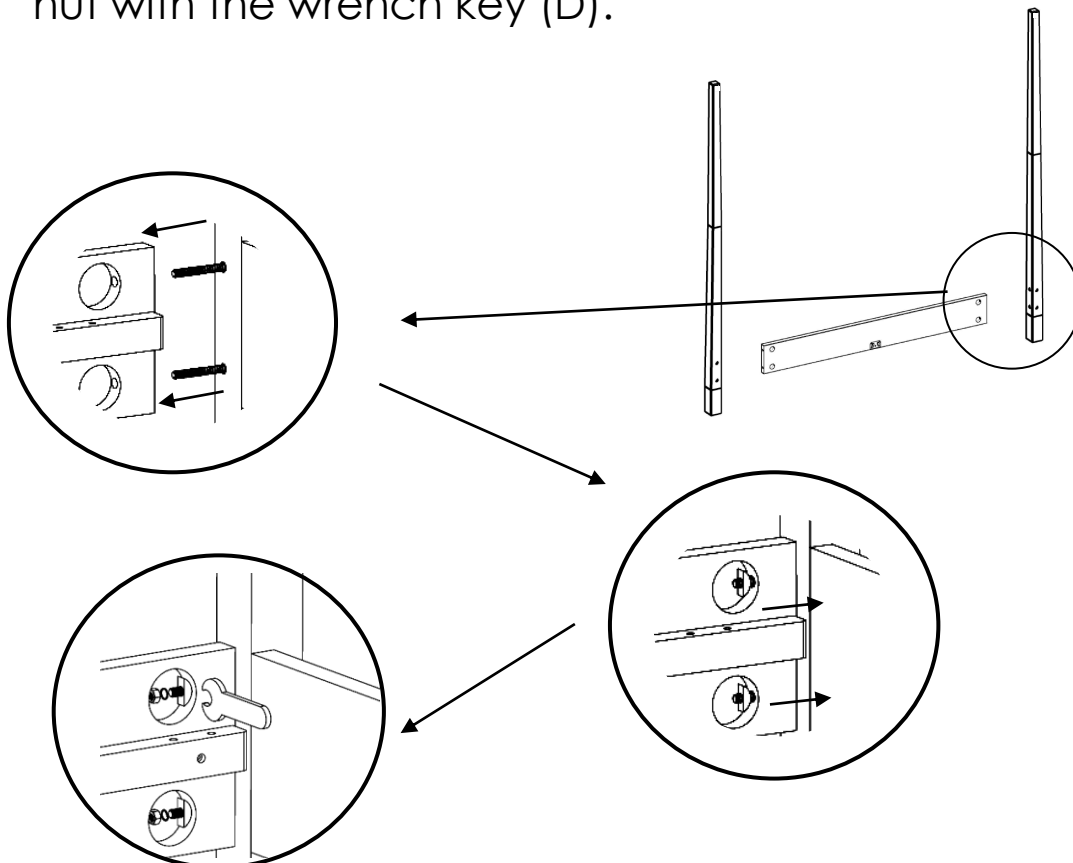

---

## Step three

- Screw the Bolt (B) into the holes provided in the headboard (1) and footboard (2) using a screw driver.

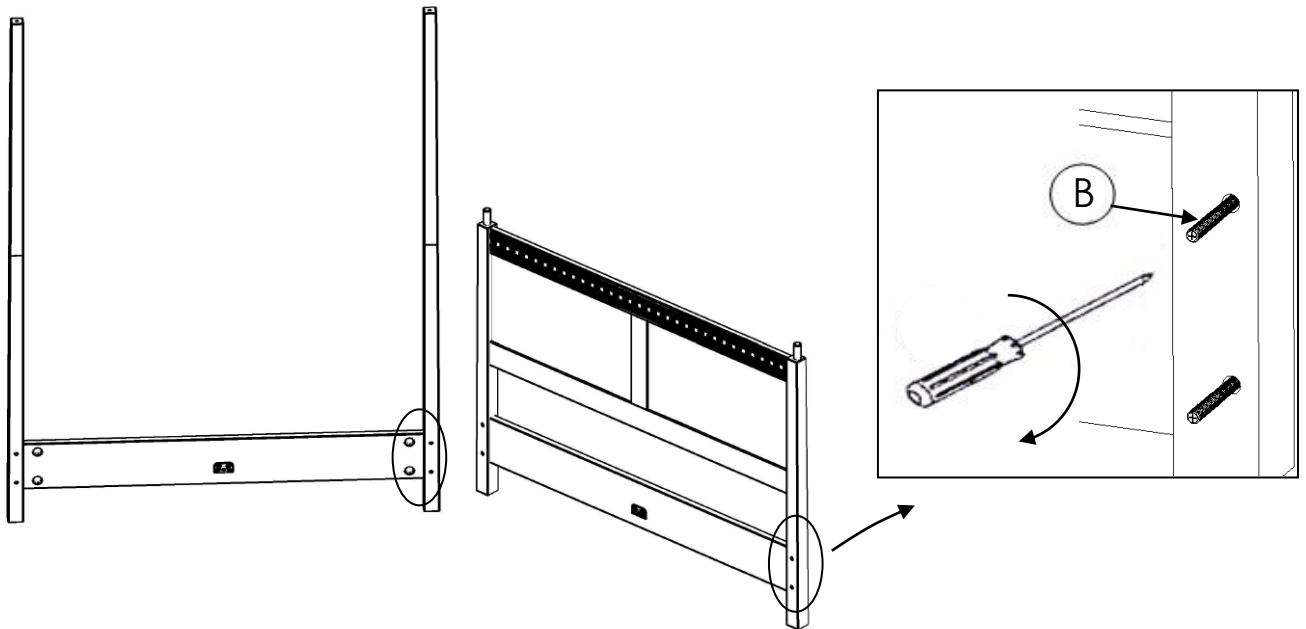

---

## Step four

- While one person holds the headboard (1) upright, the other person slides the side rail (3) over the bolts. Put the crescent washer (A) and spring washer (E) through the bolt (B). Put the nut (C) on the bolt (B) and tighten the nut with the wrench key (D).
- Both people hold the foot end (2) and LIFTING TOGETHER slot the side rails (3) over the bolts and repeat as above.

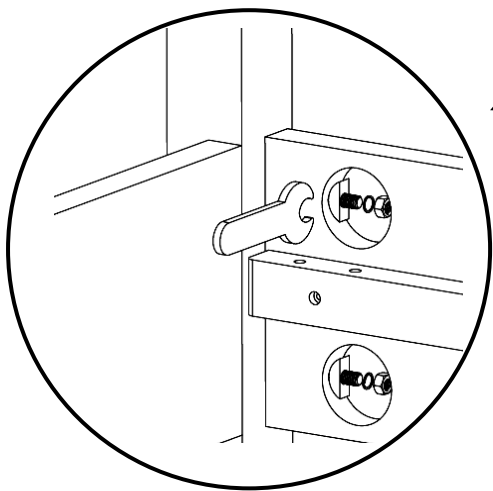
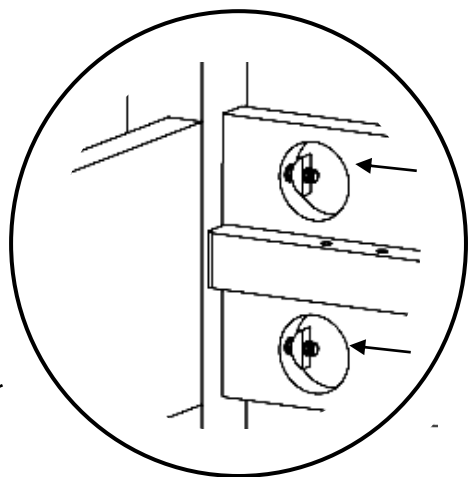
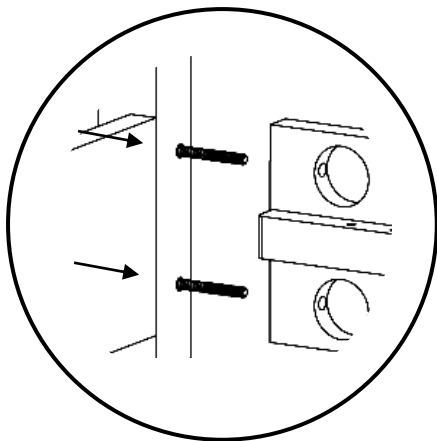
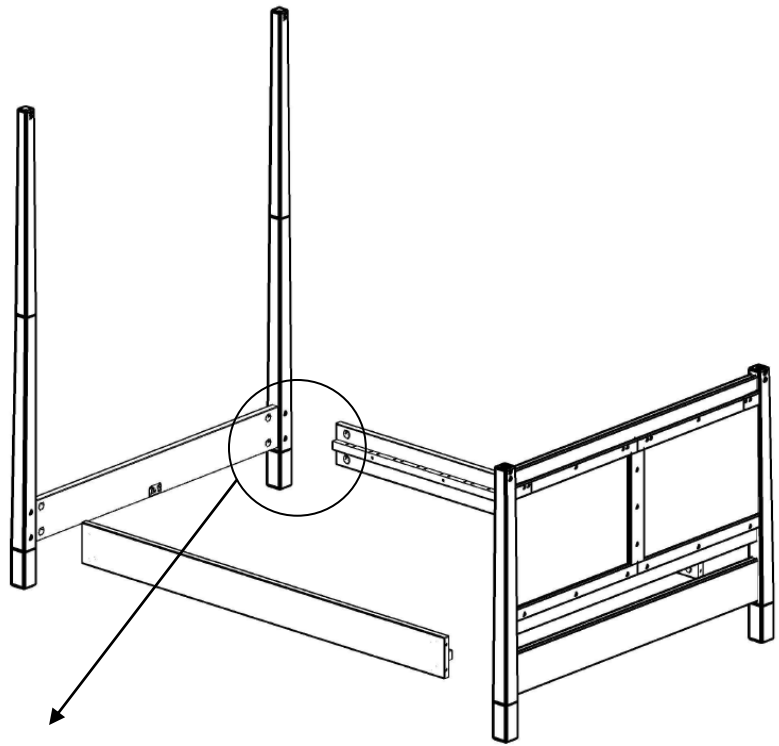

---

## Step five

Push the centre support rail (4) down into place as arrow shown to engage with clips on headboard (1) and footboard (2)

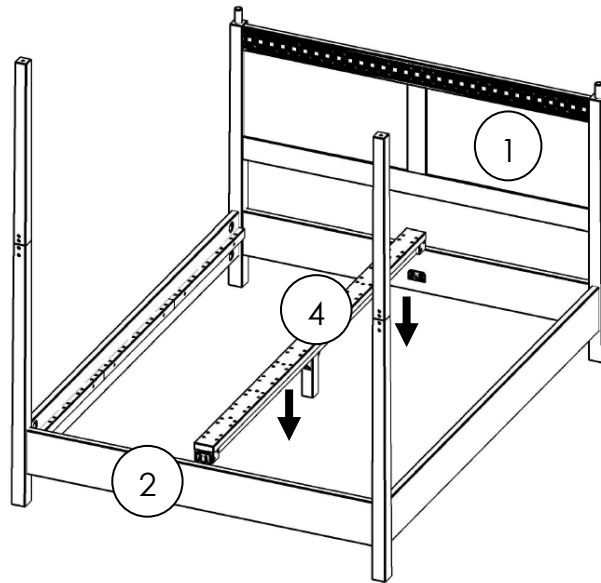

---

## Step six

- Put the top leg (9) into the holes provided in the headboard.
- Screw the joint of the upper post to the leg of the headboard with screw and cover (F) from the back side of the headboard.

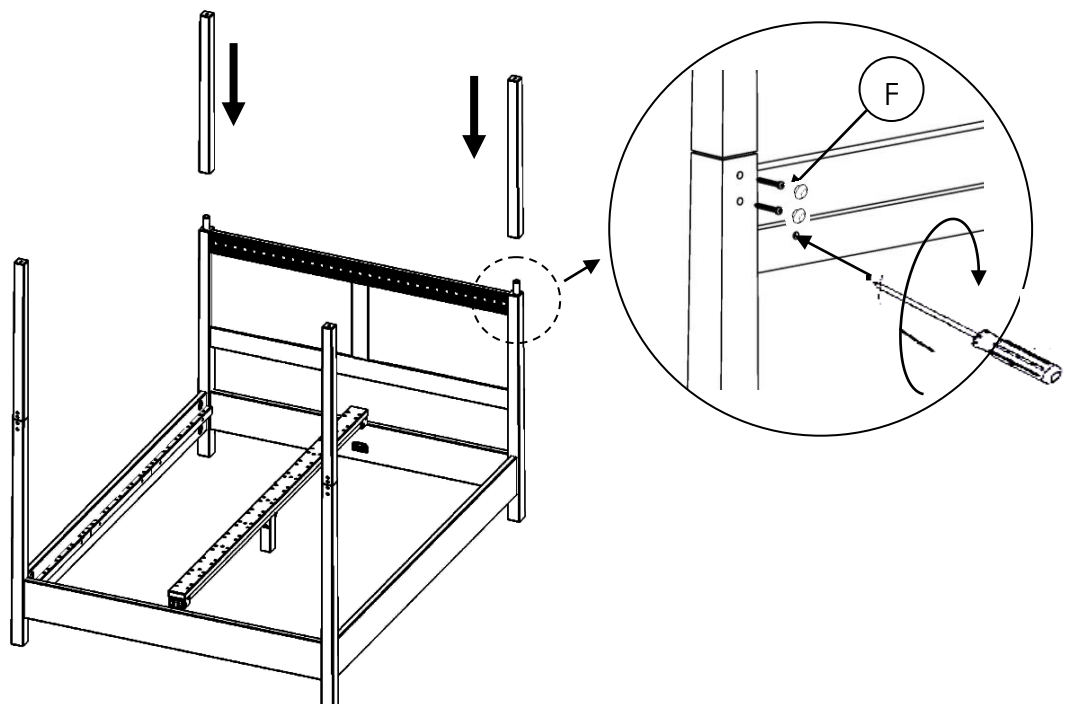

## Step seven

- Put the canopy of the side rail (6) into the holes provided in the headboard upper post (9) and footboard. Tighten using screw driver.
- Put the canopy of the headboard (7) and footboard (8) into the holes provided upon the canopy side rail (6). Put domed nut (G) and flat washer (H) on the bolt and tighten with wrench key (D).

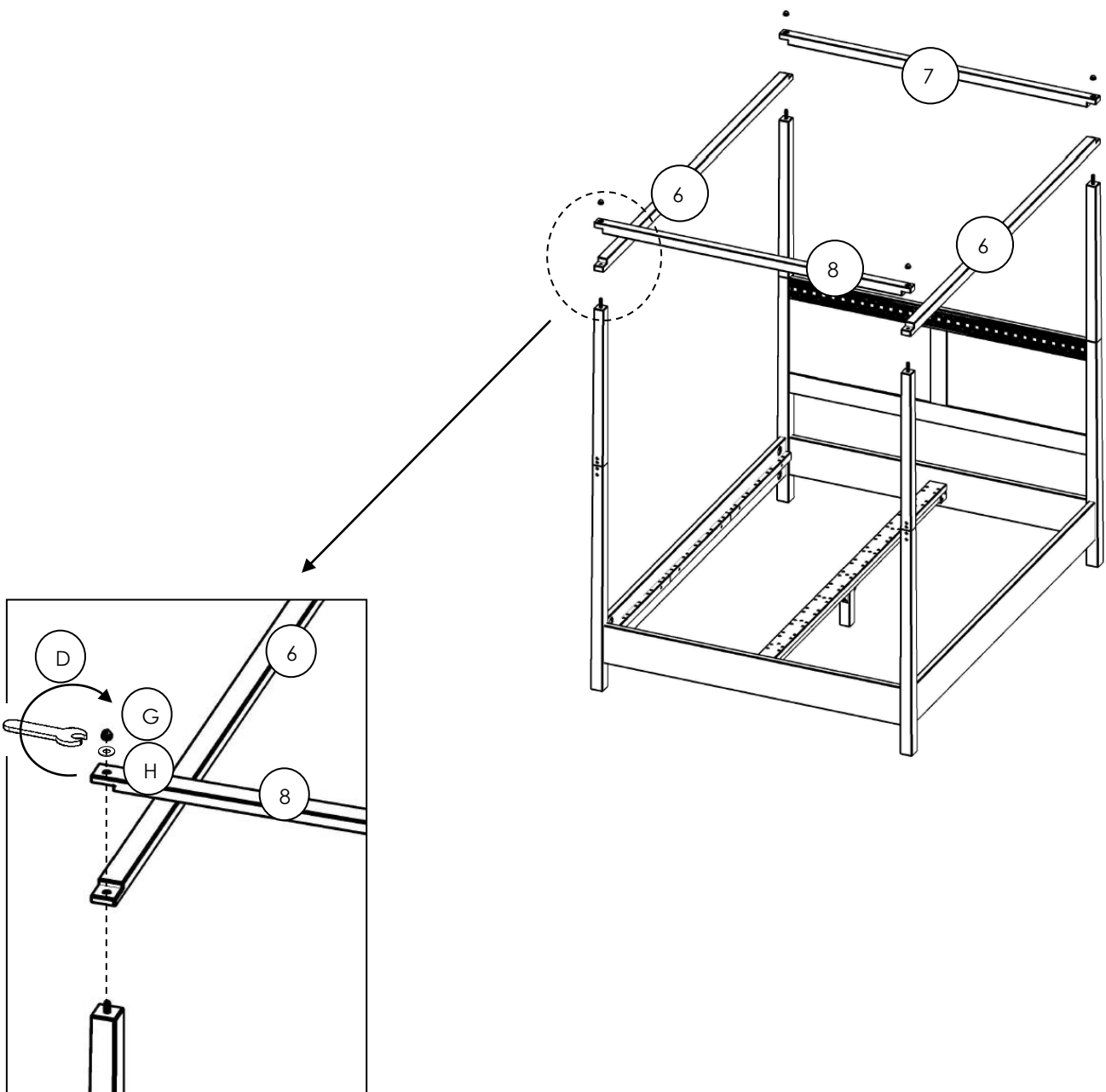

---

## Step eight

Once the plastic sockets (11) are secure onto the slats (5), push them down into the holes provided.

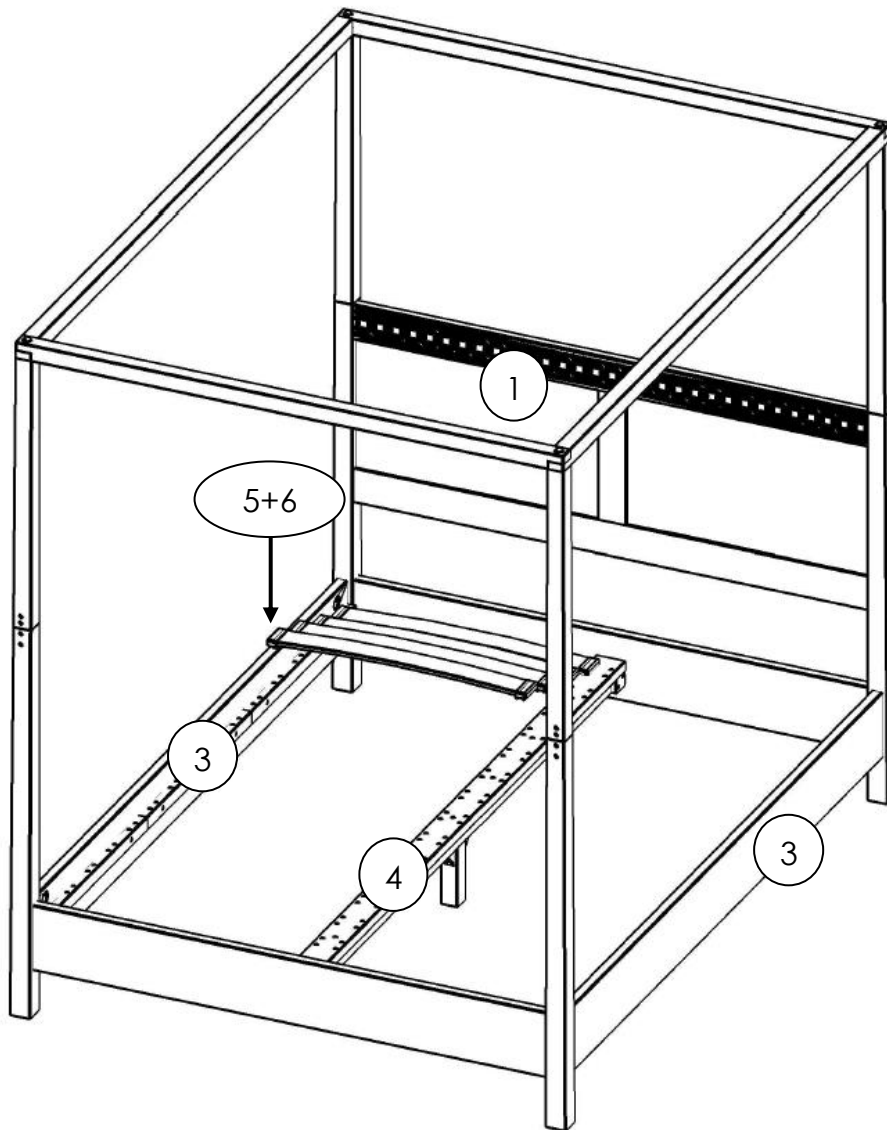



FINISH

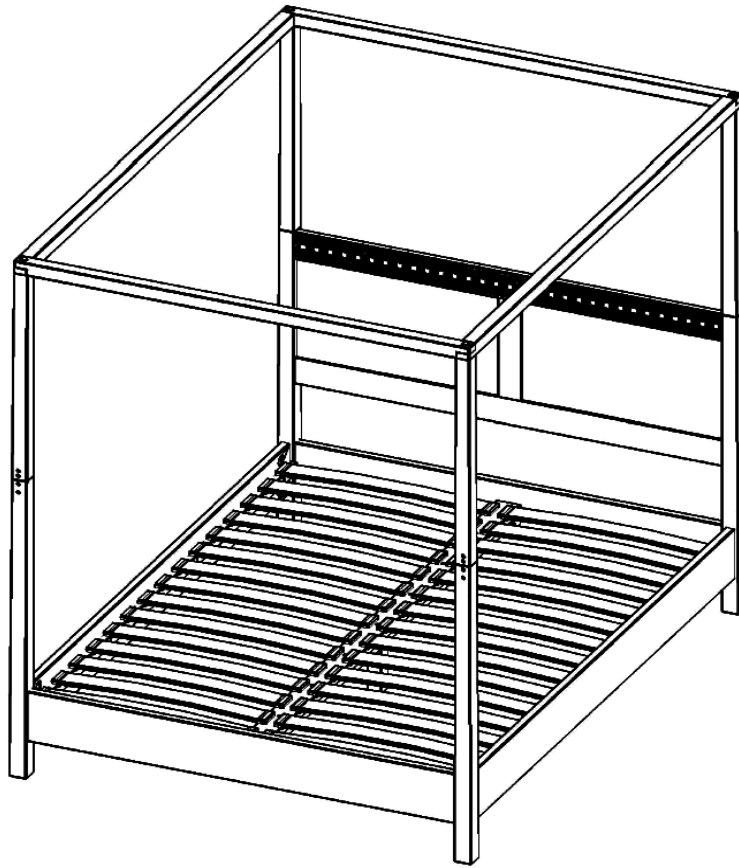

---

## Safety Instructions

---

Never drag furniture when moving it, always lift it.

When lifting or moving a table always do so from under frame and not the table top.

Periodically check all fixings to ensure none have come loose and re-tighten where necessary.

Please take care when handling or moving the furniture as careless handling may cause damage or injury.

Furniture can be dangerous if incorrectly installed. Assembly should be carried out by a competent person. No liability will be accepted for damage or injury caused by incorrectly installed or assembled furniture.

It is recommended that before moving heavy objects to a new location they are completely disassembled to avoid personal injury or damage to the furniture. Please be careful to retain all fittings when doing this.

Never overload an item such as a shelf that may be beyond what the shelf is reasonably expected to hold.

Please do not sit or place an amount of weight onto the edge of a tabletop as this may cause the table to topple.

**IMPORTANT:** If an Anti-topple device is included with this unit, you must install it in accordance with the instructions provided using fixings suitable for the wall type. If unsure, please seek advice of a professional.

---

## Care and Maintenance

---

WHEN CARED FOR PROPERLY, THIS HAND CRAFTED FURNITURE WILL PROVIDE YOU WITH YEARS OF ENJOYMENT IN YOUR HOME.

### How to care for Painted Wood furniture

Never use sharp items on the surface of the product. For example knives and utensils may damage the product. It is also advisable to place a mat under paper when writing.

Hand painted brush stroke finish's will hold up to everyday wear and tear quite nicely. However, it is important to remember that your piece is still a wood piece of furniture and should be cared for as such.

Painted furniture still requires regular dusting with a damp cloth. When very soiled wash with a solution of mild, non-abrasive detergent and warm water. Wring a cloth nearly dry and work on a small section at a time, then rinse with clear water drying after..

Never leave water to settle on the surface as this will cause damage. Any liquid spilled onto the item should be cleaned up immediately using an absorbent cloth.

AVOID chemical cleaners or liquid furniture polish including direct contact with greasy substances.

As with all natural wood products, there will be some movement within the parts as the furniture acclimatises to its surroundings, you may see slight chipping and cracks where panels meet, this is a completely natural occurrence with ALL painted products using natural solid timbers.

Painted surfaces can be carefully touched up with matching paint.

There will be various brush lines, slubs, and little inconsistencies in the painted finish, this is all part of the relaxed handfinished look and feel of hand painted collections.

WHEN CARED FOR PROPERLY, THIS HAND CRAFTED FURNITURE WILL PROVIDE YOU WITH YEARS OF ENJOYMENT IN YOUR HOME.

**PLEASE KEEP THESE INSTRUCTIONS FOR FUTURE REFERENCE**