

STEP 3

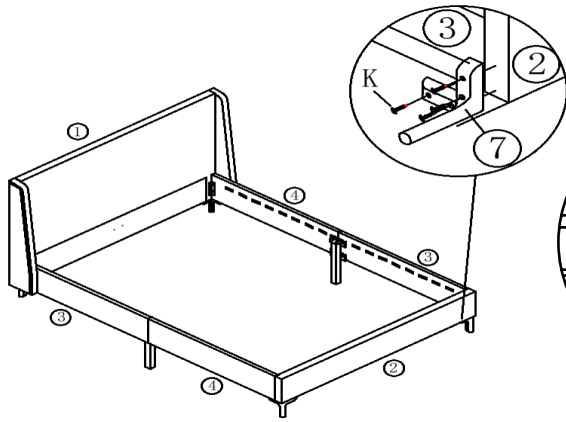

K ← 16pcs

Screw 4x45mm

Ensure to align screw holes with the centre of the frame, use the black fabric as a guide.

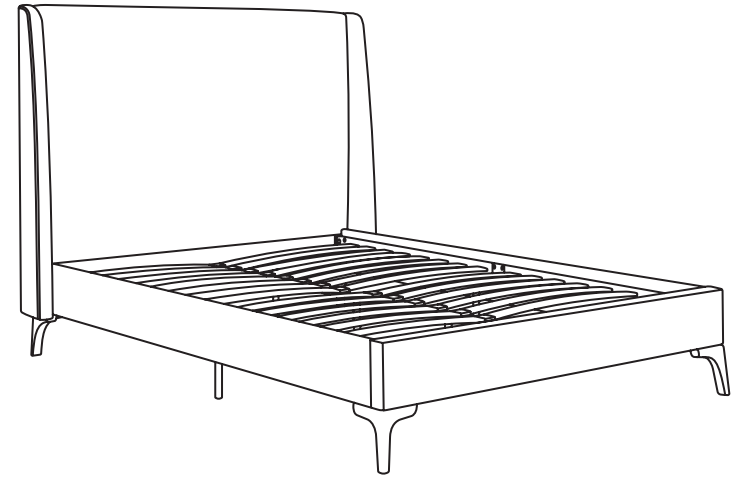

KY409 BED

Thank you for your purchase. The following care instructions will allow you to make the most of your bed; helping to prolong the look and life of it by preventing wear and damage.

IMPORTANT INFORMATION

PLEASE ENSURE YOU READ THIS LEAFLET BEFORE USING YOUR BED. DO NOT DISCARD OF ANY PACKAGING UNTIL YOU HAVE CHECKED THE PRODUCT THOROUGHLY. THE FABRIC ON THIS PRODUCT IS FLAME RETARDANT TREATED AND THEREFORE SHOULD BE SPECIALIST UPHOLSTERY CLEANED ONLY.

STEP 4

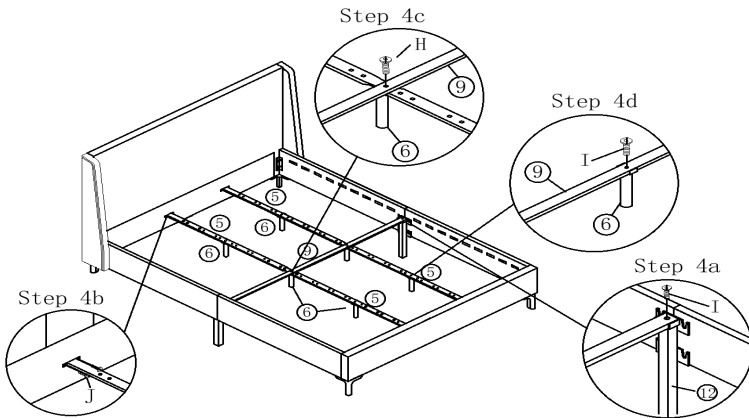

H ← 2pcs
Bolt M6x35

I ← 6pcs
Bolt M6x25

J ← 8pcs
Bolt M6x20

STEP 5

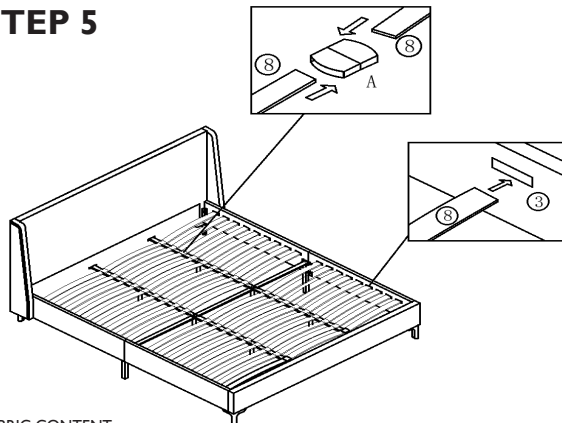

A ← 36pcs
Double
Plastic Cap

FABRIC CONTENT
MAIN FABRIC 100% POLYESTER
OTHER FABRIC (VISIBLE)
NON-WOVEN FABRIC 100% POLYESTER

CARING FOR YOUR BED

- Pre-brush fabric with a soft brush and then gently vacuum.
- Plump any accent/removable cushions regularly to prevent them becoming mis-shaped or flat.
- Use a microfibre cloth to remove dust from wooden surfaces.
- In the event of a spill or stain, use specialist upholstery cleaner or cleaning services.

SUNLIGHT AND HEAT DAMAGE

- Avoid contact with direct sunlight. If needed, move items or change their position to avoid the same area being exposed to repeated sunlight/heat.
- Do not place your bed close to fire places and/or radiators.
- Hot objects such as mugs/plates can permanently mark the fabric and wood, avoid placing these on the bed.

SAFETY WARNINGS

- Do not allow children or pets to climb or jump on the bed.
- Avoid contact with sharp objects such as buckles, toys and jewellery as these can easily snag, tear and/or pull the fabric.
- Avoid the risk of entrapment by using the bed as intended; with a mattress.
- Keep small parts away and out of reach of children and pets.

PARTS LIST

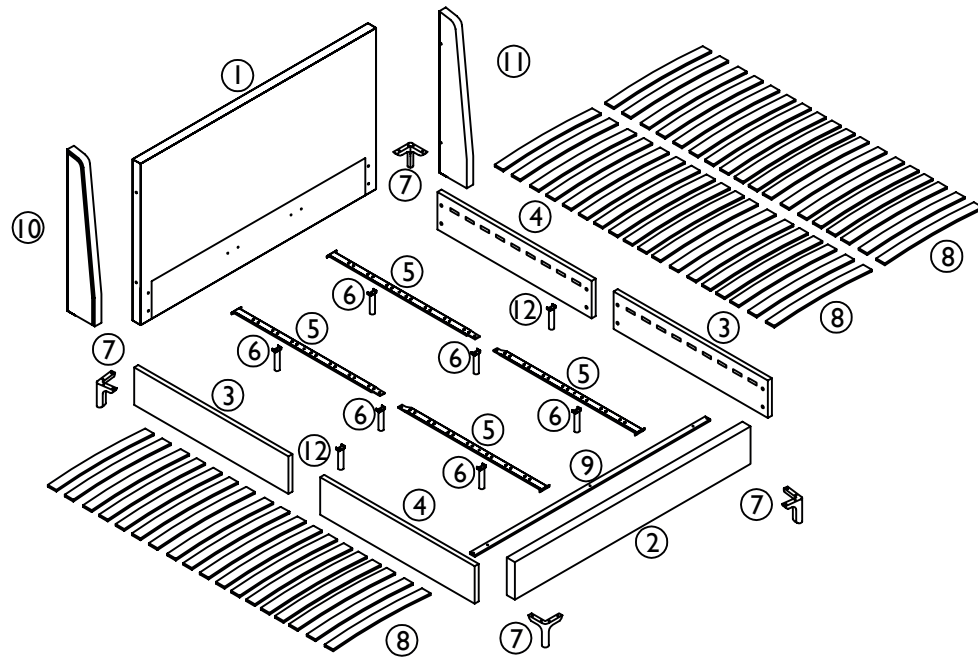

HARDWARE LIST

LABEL	IMAGE	DESCRIPTION	QTY	LABEL	IMAGE	DESCRIPTION	QTY
A		Double Plastic Cap	36	H		Bolt M6 x 35	2
B		Bolt M8 x 45	4	I		Bolt M6 x 25	6
D		Bolt M8 x 25	8	J		Bolt M6 x 20	24
E		Spring Washer	8	K		Screw 4 x 45mm	16
F		Washer M8	12	L		Connection Plate Left	2
				R		Connection Plate Right	2

TOOL LIST

LABEL	IMAGE	DESCRIPTION	QTY
T-1		Screw Driver (not provided)	1
T-2		Allen Key M5	1
T-3		Allen Key M4	1
T-4		Spanner	1

ASSEMBLY INSTRUCTIONS

Unpack your bed and check that all the parts on the Parts List are present. If any are missing, please contact the retailer from whom you purchased the product. We do not advise the use of power tools for assembly - please use the tools advised in the Tool List.

STEP 1

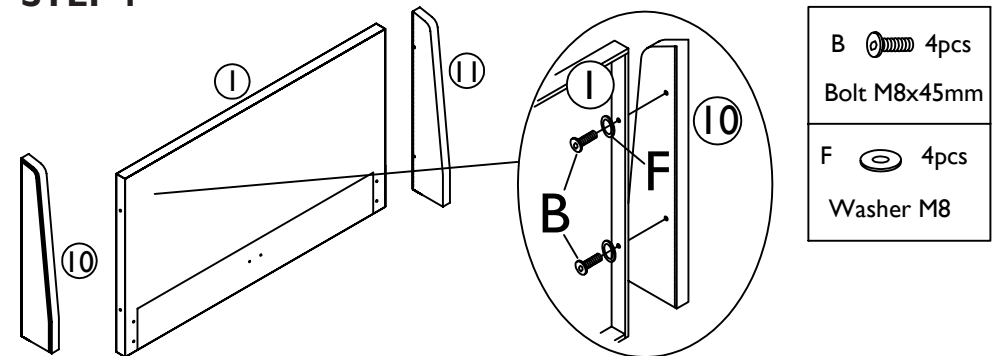

B		4pcs
F		4pcs

STEP 2

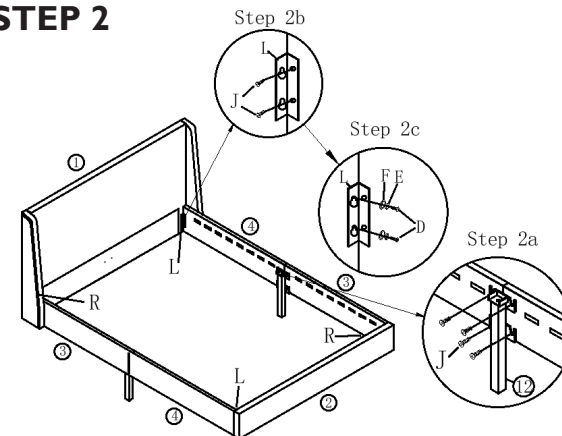

L		2pcs	R		2pcs
D		8pcs	E		8pcs
F		8pcs	J		16pcs