

# Curves Storage Bed

## INSTRUCTIONS

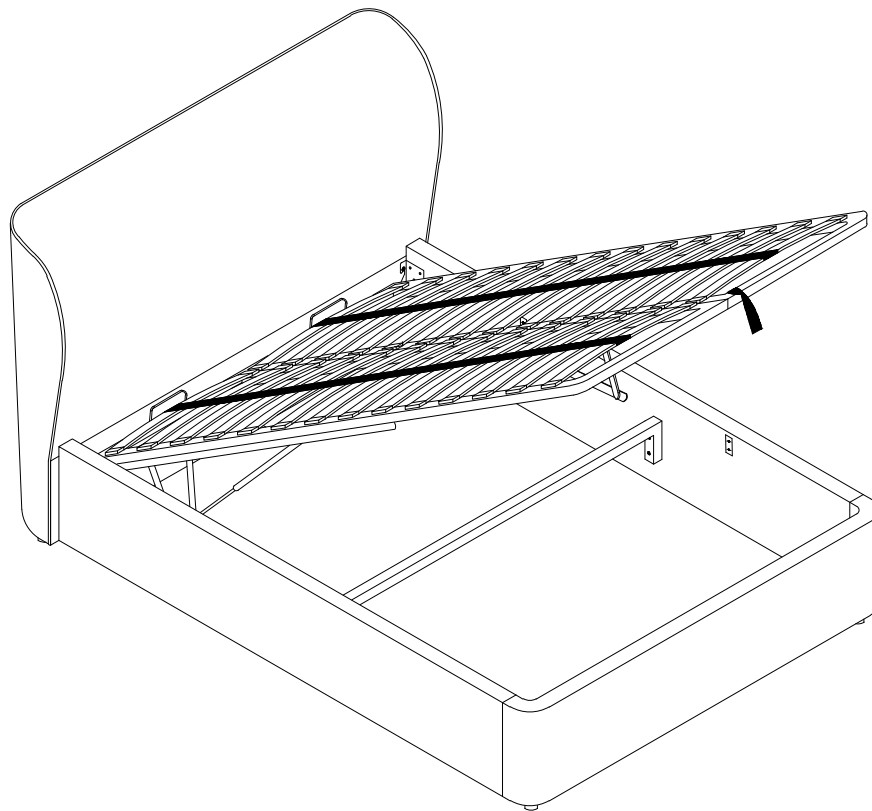

**Dunelm**

[www.dunelm.com](http://www.dunelm.com)

**Dear Customer**

Check the pack and make sure you have all the parts listed below. If not, contact the helpline on **03451 656565** who will be able to help you

**Safety advice**

**IMPORTANT** - The first step you need to take is to ensure your safety! Please take the time to read and understand these instructions before assembling your furniture.

Please keep these instructions for future reference.

Keep children and animals away from the assembly area. This furniture contains small parts that could cause choking if swallowed.

Keep all plastic wrapping materials away from babies and children to avoid danger of suffocation.

Ensure that all packaging is disposed of carefully and responsibly.

From time to time check that there are no loose fittings on the unit, re-tighten when necessary.

Two people may be required for the assembly of this product.

Once items are part or fully assembled, they are not returnable unless faulty.

This item is not for outdoor use - unless stated otherwise.

Some items will be supplied with a wall fixing strap, which we recommend is used to secure the item to the wall, to prevent a child from accidentally pulling furniture over. Furniture can be dangerous if incorrectly installed. Assembly should be carried out by a competent person. No liability will be accepted for damage or injury caused by incorrectly installed or assembled furniture.

Only use the strap to lift and lower the bed frame to avoid finger entrapment!

Please do not allow children or pets inside the storage area.

Please be careful when lifting. Only lift with mattress on top. To be operated by adults only.

Do not overload internal storage base.

Ensure that the ottoman is FULLY open before accessing the storage area.

Do not stand inside the internal storage area of the bed.

# Component parts supplied

## Box 1/4

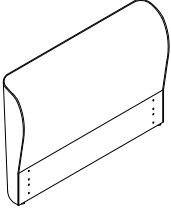
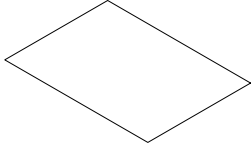
Ref	Dimensions	Visual	Qty
1	Headboard (4'6-1565X1005mm) (5'-1715X1005mm) (6'-2015X1005mm)		1
6	Non Woven Fabric (4'6-1420X2000mm) (5'-1580X2100mm) (6'-1880X2100mm)		1

## Box 2/4

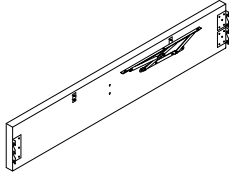
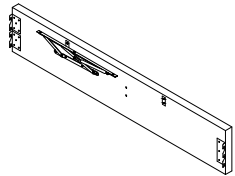
Ref	Dimensions	Visual	Qty
3	Side Rail (4'6-1860X340mm) (5'-1960X340mm) (6'-1960X340mm)		1
4	Side Rail (4'6-1860X340mm) (5'-1960X340mm) (6'-1960X340mm)		1

## Box 4/4

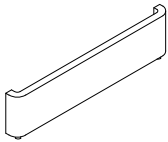
Ref	Dimensions	Visual	Qty
2	Footboard (4'6-1490X350mm) (5'-1640X350mm) (6'-1940X350mm)		1

## Box 3/4

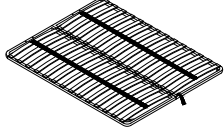
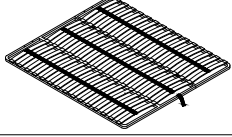
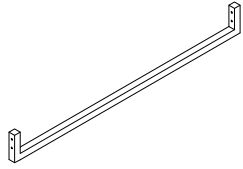
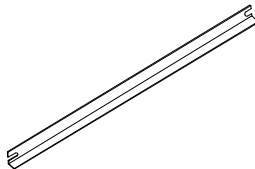
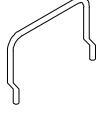
Ref	Dimensions	Visual	Qty
5	Metal Frame Base (4'6-1355X1900mm) (5'-1505X2000mm) (6'-1805X2000mm)	Double / King 	1
		Super King 	1
7	U' Shaped Cross Bar (4'6-1380X25mm) (5'-1530X25mm) (6'-1830X25mm)		1
8	Metal Horizontal Support Bar (4'6-1345mm) (5'-1495mm) (6'-1795mm)		Double King 1
			Super King 2
9	Mattress Stopper (210X125mm)		2

# Parts and fittings

Fixtures and fittings  
supplied (actual size)

Ref	Dimensions	Qty
A	M8X25mm	18
B	M8X12mm	24
C	M8X17mm	34
D	M5	1
E	M8X50mm	10
F	M8X13mm	6
G	M14	1
H	Stator	2
I	M8	2

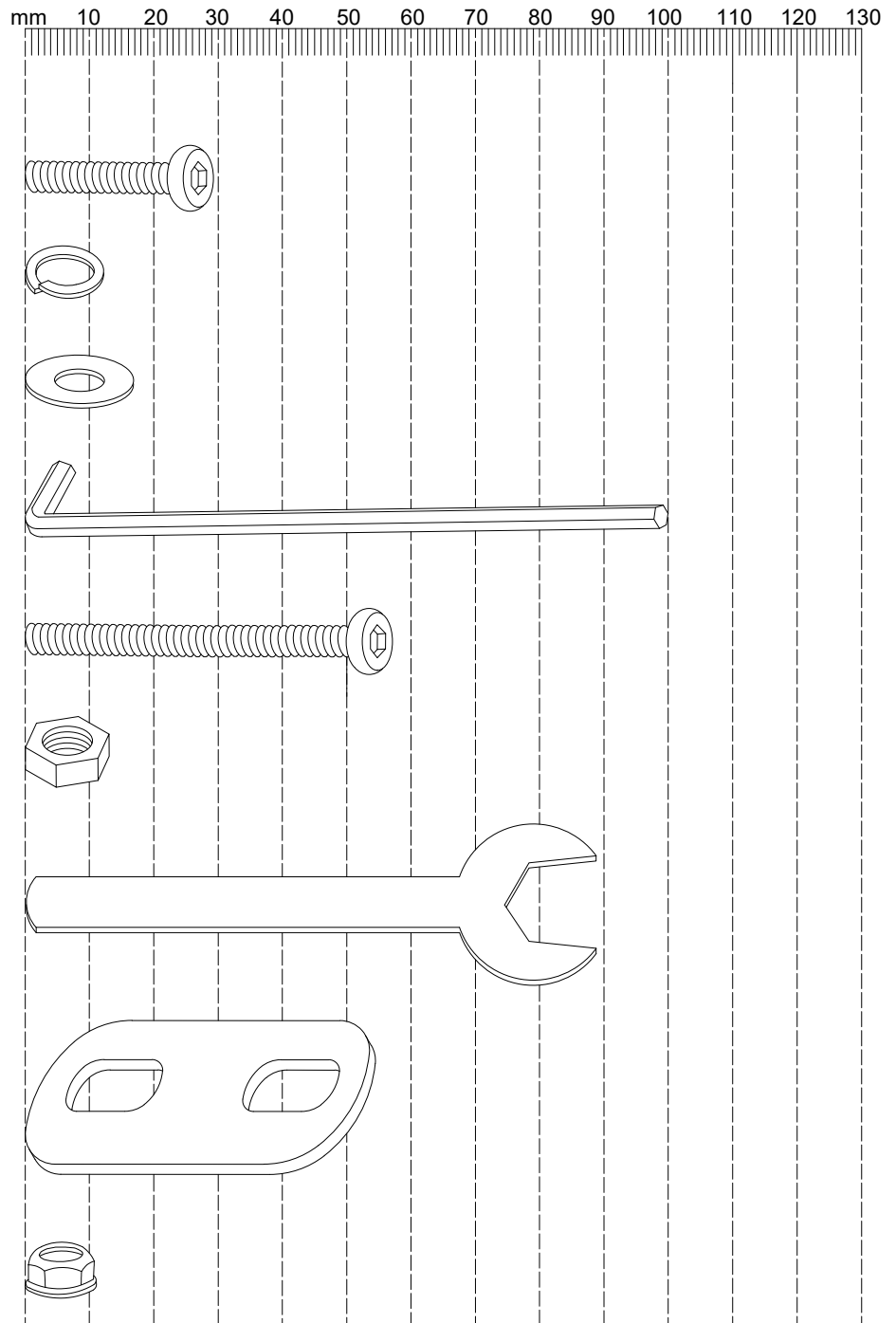

Step 1:

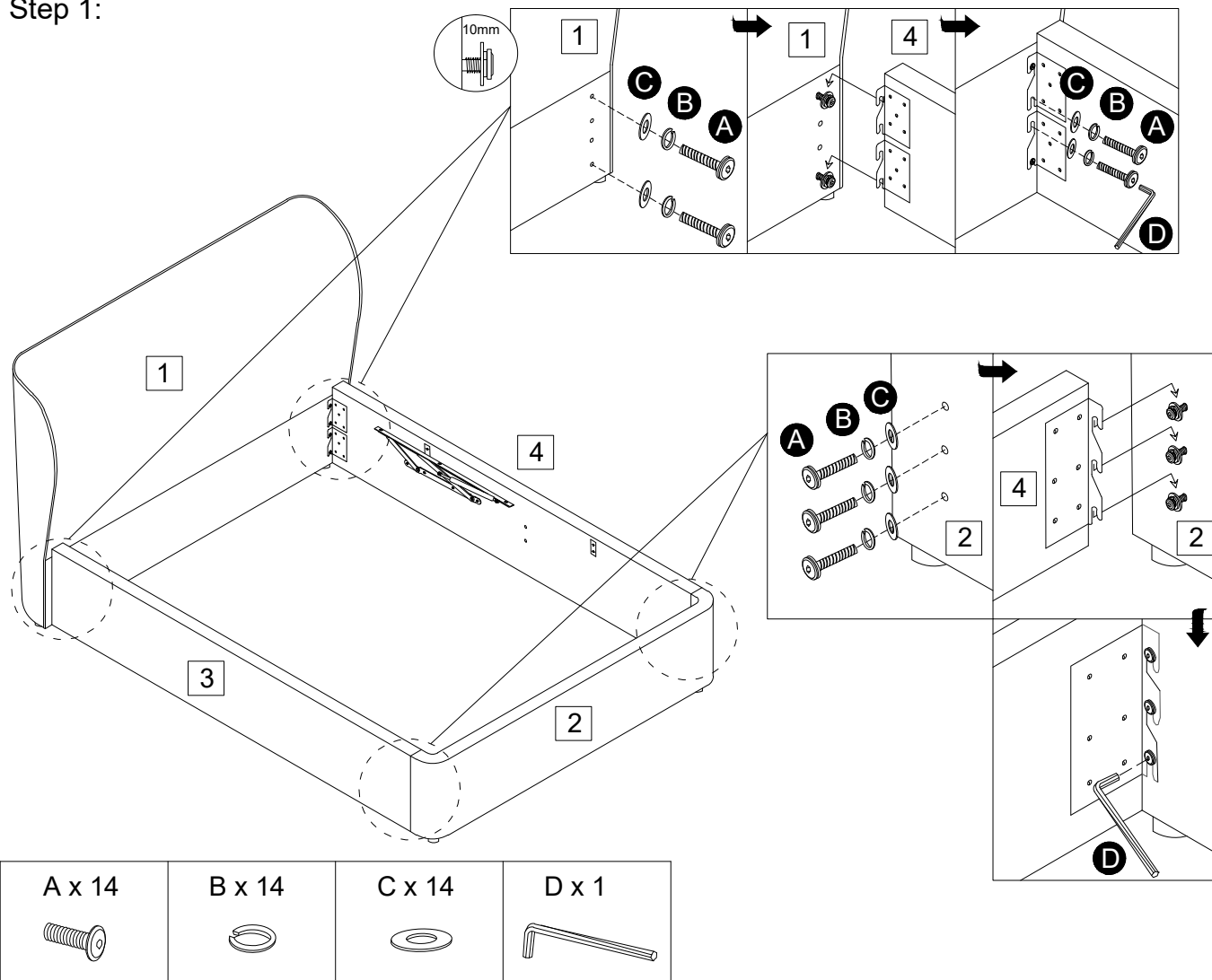

Step 2:

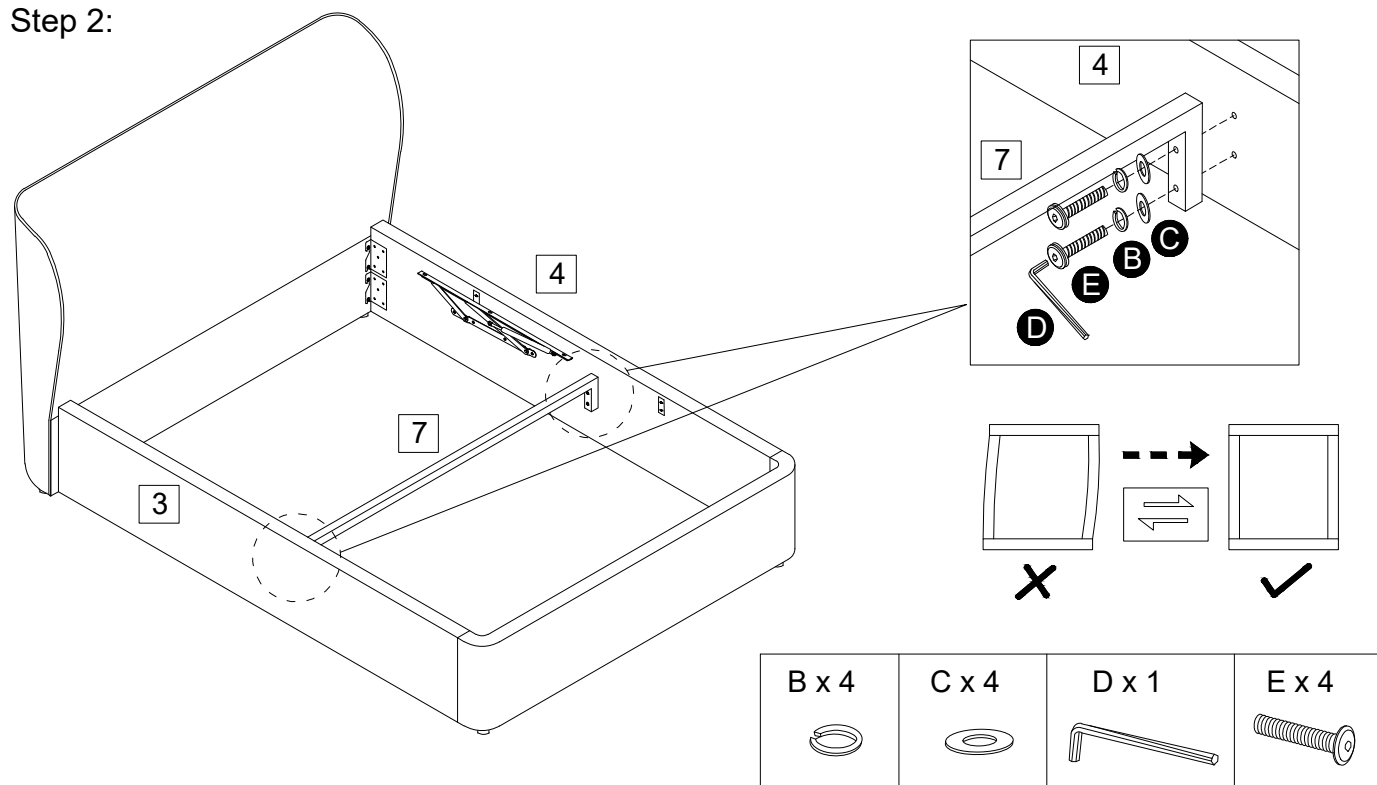

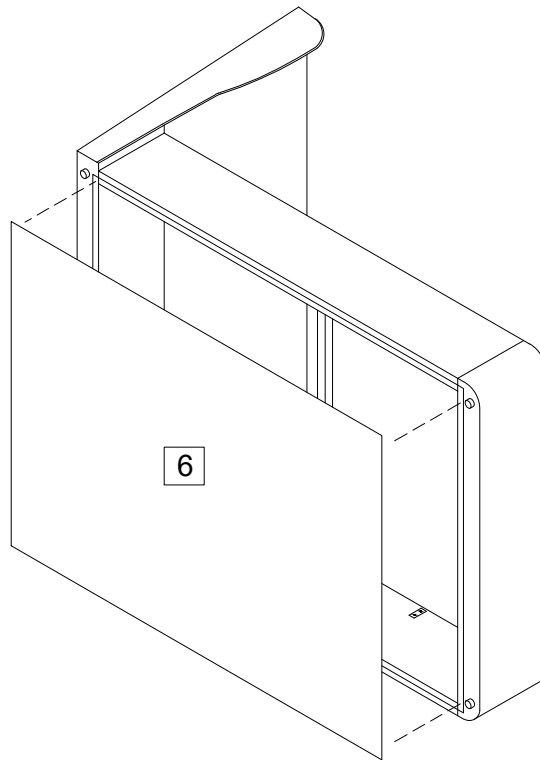

Step 3:

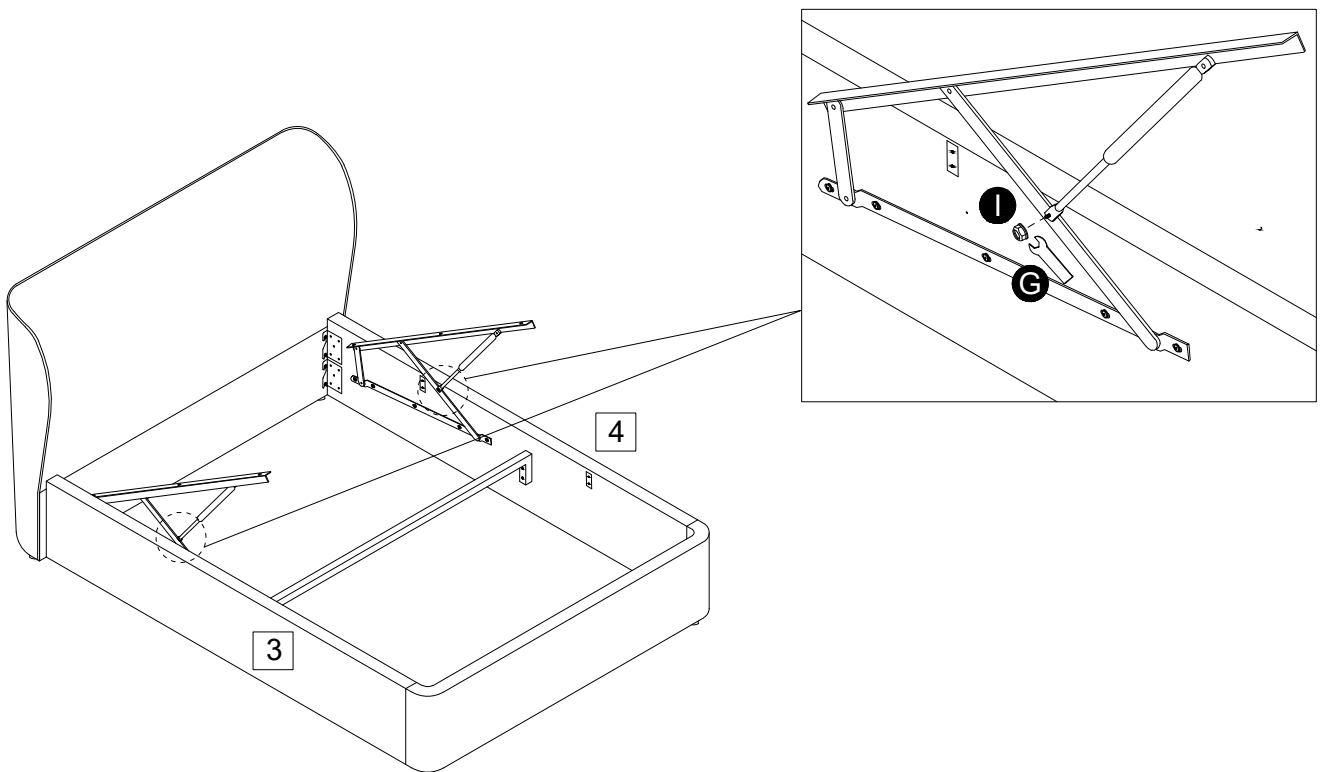

Step 4:



G x 1	I x 2
	

Step 5:

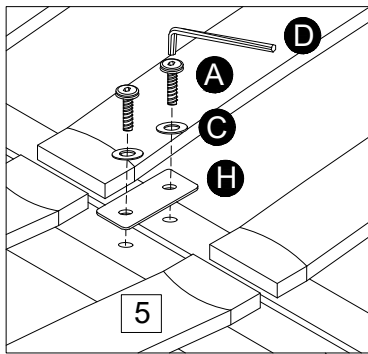

Double / King

5

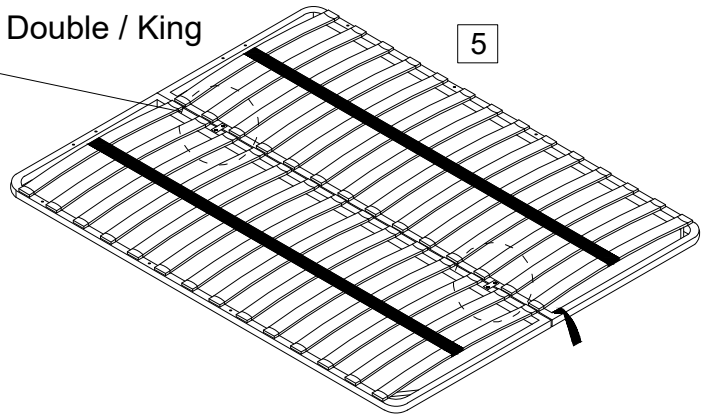

Super King

5

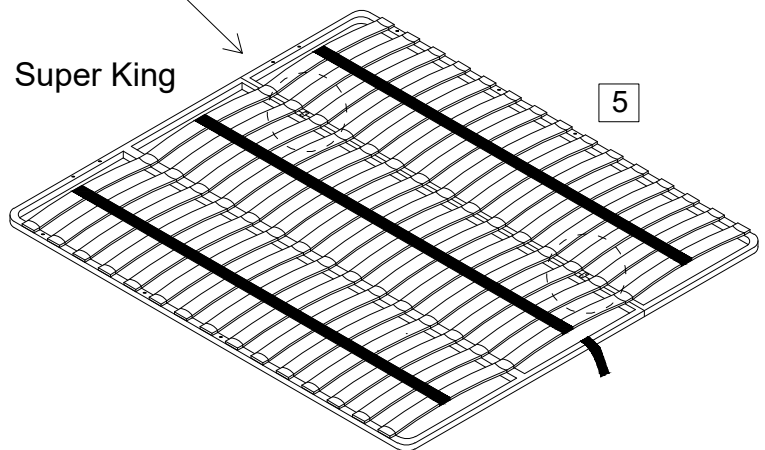

A x 4



C x 4



D x 1



H x 2



Step 6:

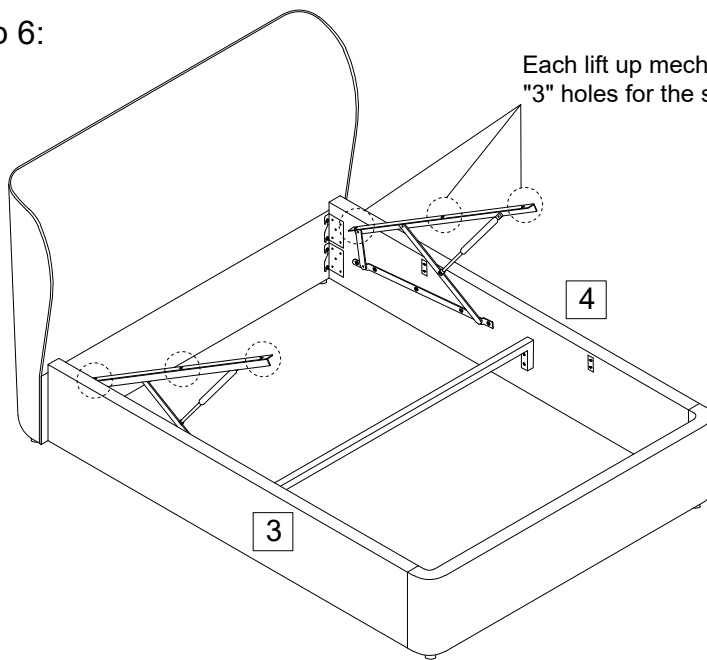

Each lift up mechanism has "3" holes for the screw.

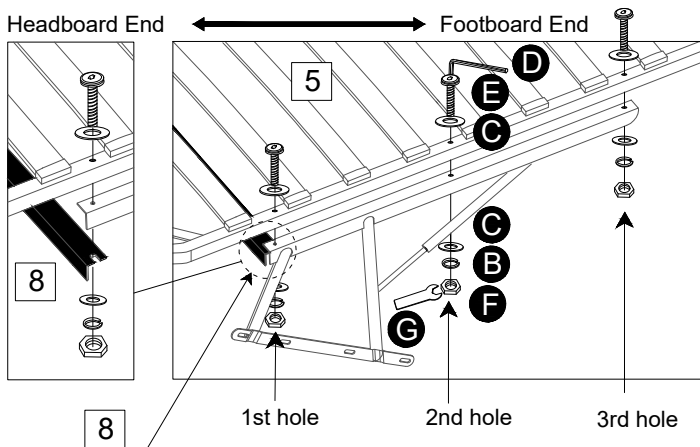
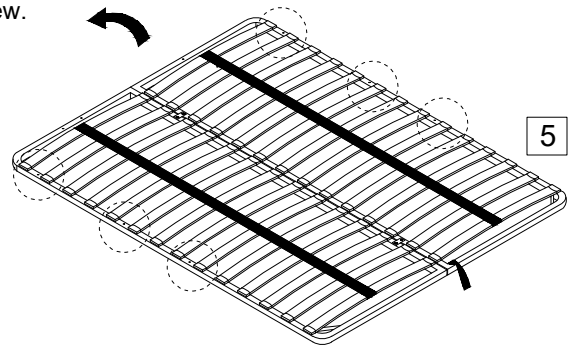

Double / King

**Warning:** Don't 100% tighten any accessory until all of them are fixed accordingly.

**8**  
Metal horizontal support bar

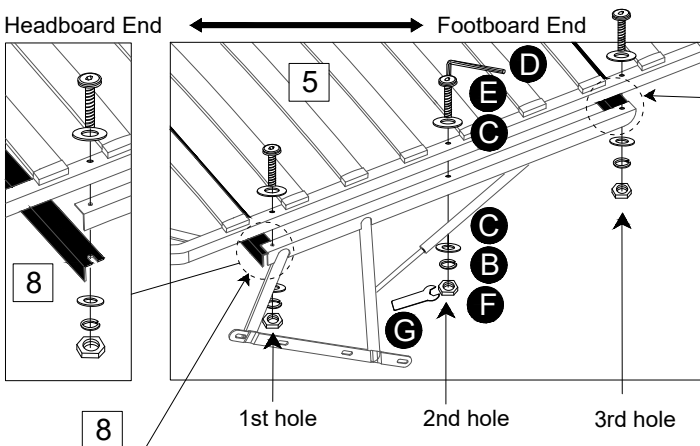

Super King

**8**  
Metal horizontal support bar

B x 6	C x 12	D x 1	E x 6	F x 6	G x 1



Step 7:

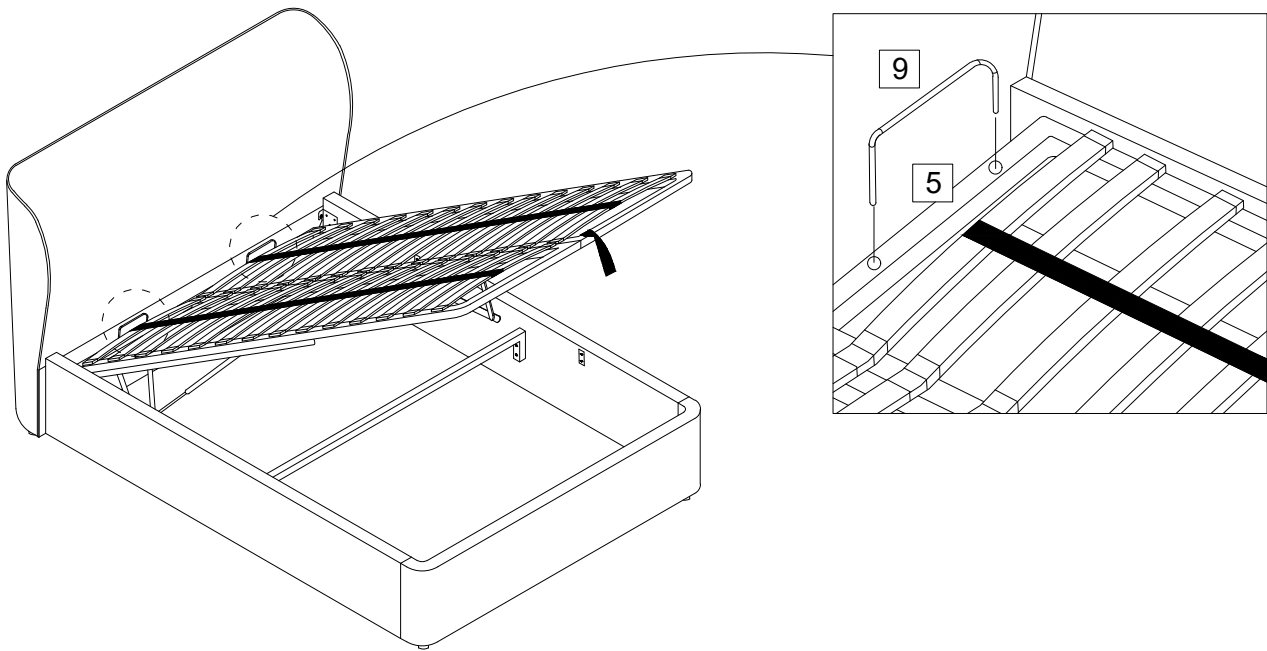

Product Size

DOUBLE : W1570 x L2190 x H1010/350mm

KING : W1720 x L2290 x H1010/350mm

SUPER KING : W2020 x L2290 x H1010/350mm

Internal Dimensions

DOUBLE : W1375 x L1925mm

KING : W1525 x L2025mm

SUPER KING : W1825 x L2025mm

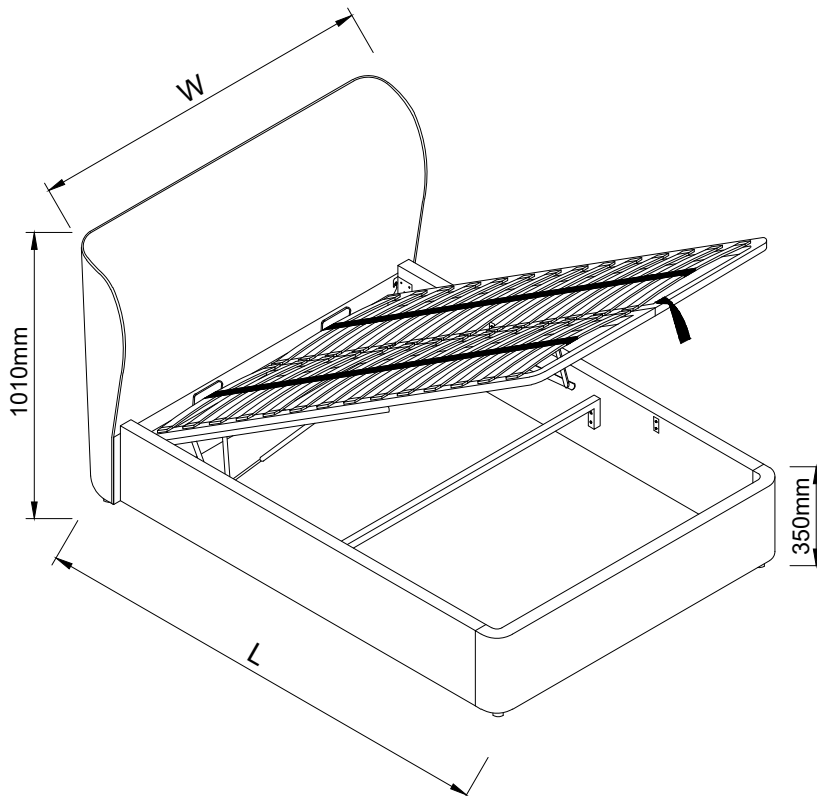

# Upholstery care advice

## Regular care advice

Vacuum clean your upholstery at least once a week, dust removal may be improved by pre-brushing with a soft cloth.

All reversible cushions should be turned daily, and their positions switched, this will help prevent excessive soiling and even out wear.

## Cushion care

It is essential that all fibre cushions are given a vigorous plumping by shaking and squeezing to redistribute the fibre on a daily basis. This will add air back into the fibres to prevent the fibre from going flat and lumpy.

## General care advice

For items with wooden legs/ feet never place on a damp floor.

Keep upholstery out of direct sunlight to avoid discolouring.

Do not place the furniture in a conservatory, excessively dry or humid conditions.

Avoid sharp items such as toys, jean rivets and buckles coming into contact with the upholstery as these can easily snag, tear or pull the fabric.

To maintain the appearance and durability of your suit, restrain children and pet from climbing and jumping on the sofa.

Leather is a natural product and can display natural marks and characteristics such as healed scars, grain directions and creases. These are natural features not faults. Aniline leather will mark naturally and have an antique affect after years of use, this is part of the nature of the leather. Care for the leather is required to maintain it over the years.

Velvet has a directional pile resulting in colour change when the pile is brushed the wrong way or when the light catches it. Velvet can easily mark and may appear crushed when new, to resolve this sweep with a clothes brush to refresh the pile. Over time the pile may crush due to wear, but this is a characteristic of the velvet. For extreme cases the pile can be restored by steaming but consult a professional first.

## For accidental spills or stains

Don't rub or scrub with a cloth as this could damage the fabric and remove the colour.

Don't use washing up liquid, detergents or bleach to remove stains.

Don't soak or allow fabric to become wet.

Do blot or soak up spills immediately using a dry soft colourfast cloth.

Do use specialist upholstery cleaner if needed, always follow the manufacturer's instructions and always test on a hidden area to check colour fastness.

Manufactured in China for  
Dunelm (Soft Furnishings) Ltd. LE7 1AD  
& Dunelm (Soft Furnishings) Londonderry Ltd. BT48 8QN  
**dunelm.com**