











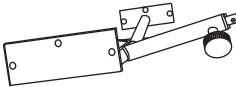



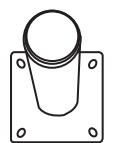

|   |   |   |
|---|---|---|
| ① x1<br><br>chair base (big)     | ② x1<br>                         | ③ x1<br><br>chair seat (big)     |
| ④ x1<br><br>ottoman base (small)  | ⑤ x2<br><br>backrest             | ⑥ x1<br><br>ottoman seat (small) |
| ⑦ x1<br><br>headrest             |   |   |
| ⑧ x1<br><br>ottoman base (small) | ⑨ x1<br><br>ottoman seat (small) | ⑩ x1<br><br>ottoman seat (small) |
| A x6<br><br>M6*25mm             | B x10<br><br>M6*18*1mm          | C x2<br><br>M8*25mm             |
| D x3<br><br>M8*45mm            | E x3<br><br>M8*14mm            | F x2<br><br>M8*22*1.5mm        |
| G x4<br><br>M6*20mm            | H x1<br><br>M5                 | I x1<br><br>14#                |

# MC606/MC606-G



30 min

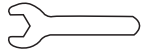
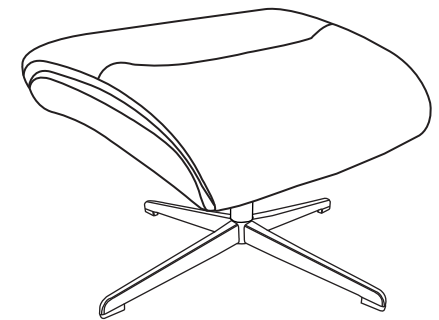
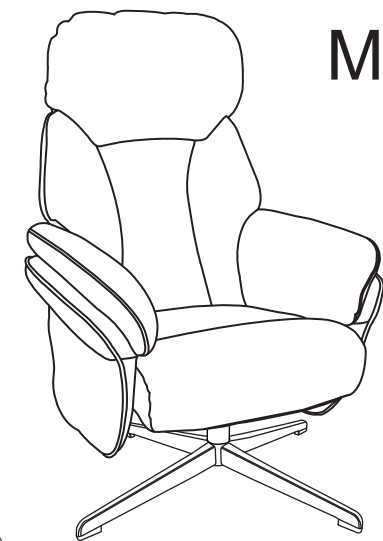
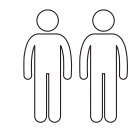

x2

**1**

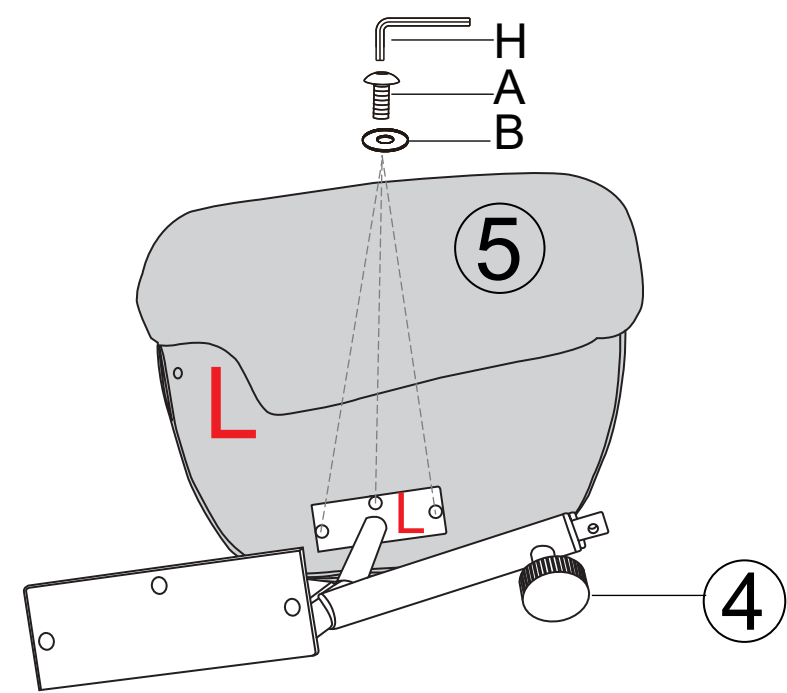

2

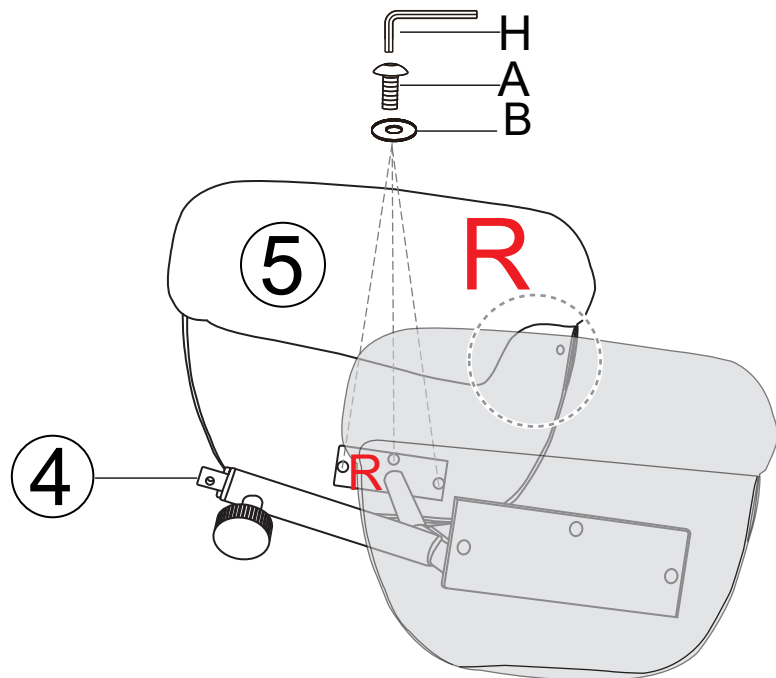

3

Insert seat cushion between armrest

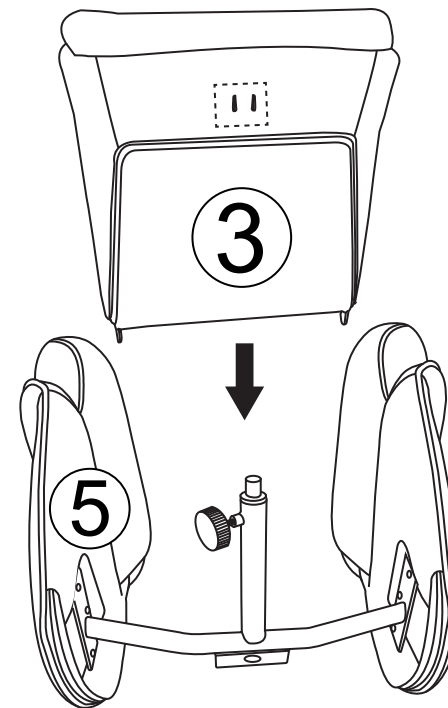

4

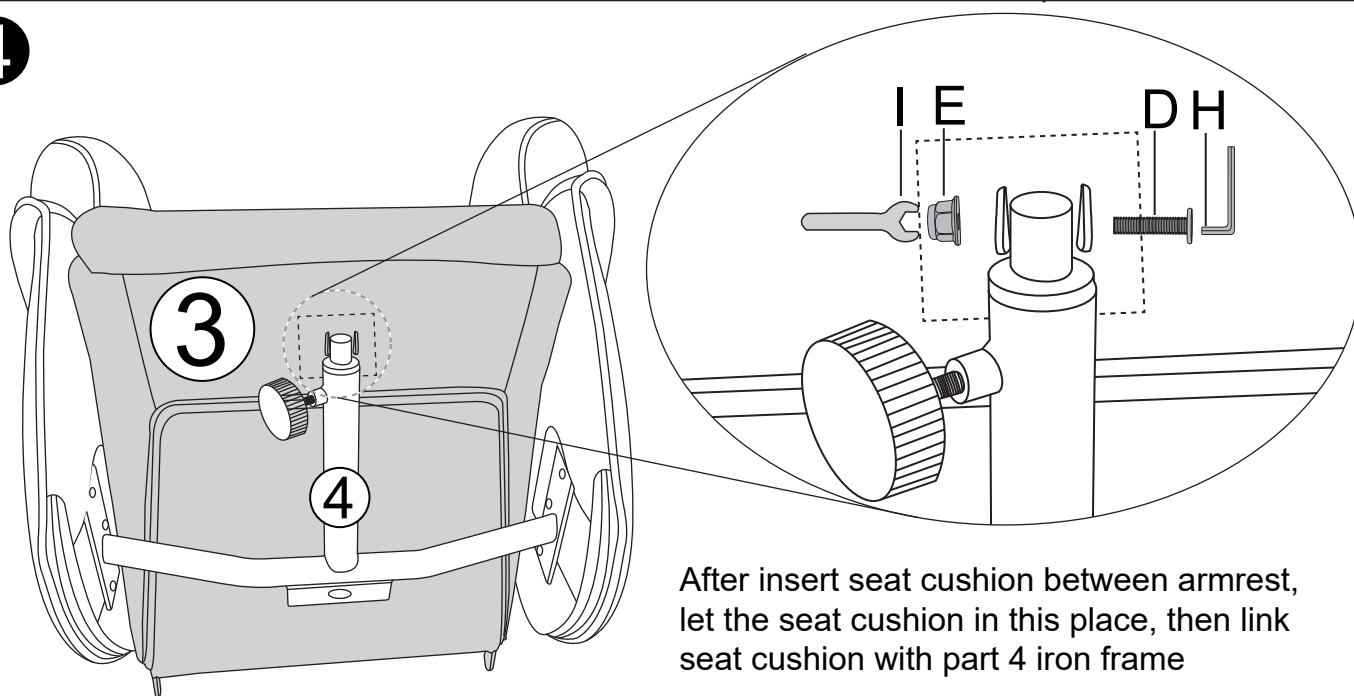

After insert seat cushion between armrest, let the seat cushion in this place, then link seat cushion with part 4 iron frame

5

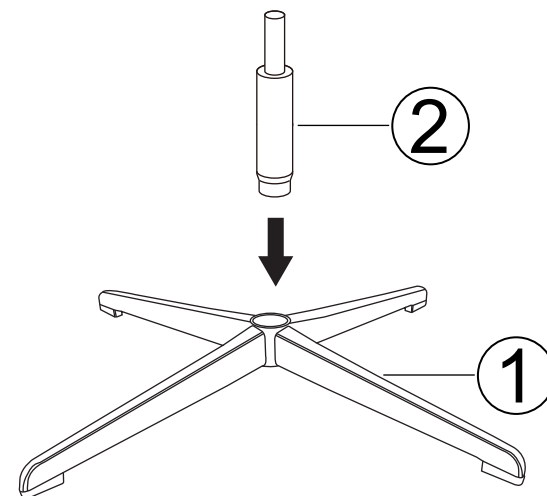

6

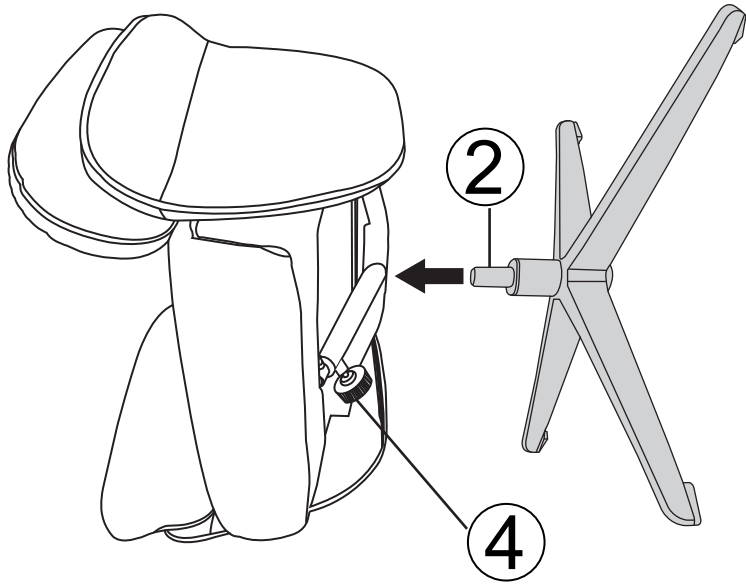

7

insert headrest into bakcrest,let them link

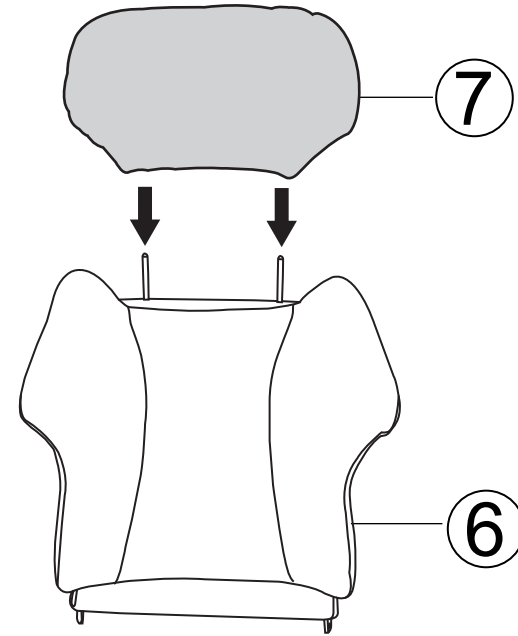

8

Assemble backrest with seat

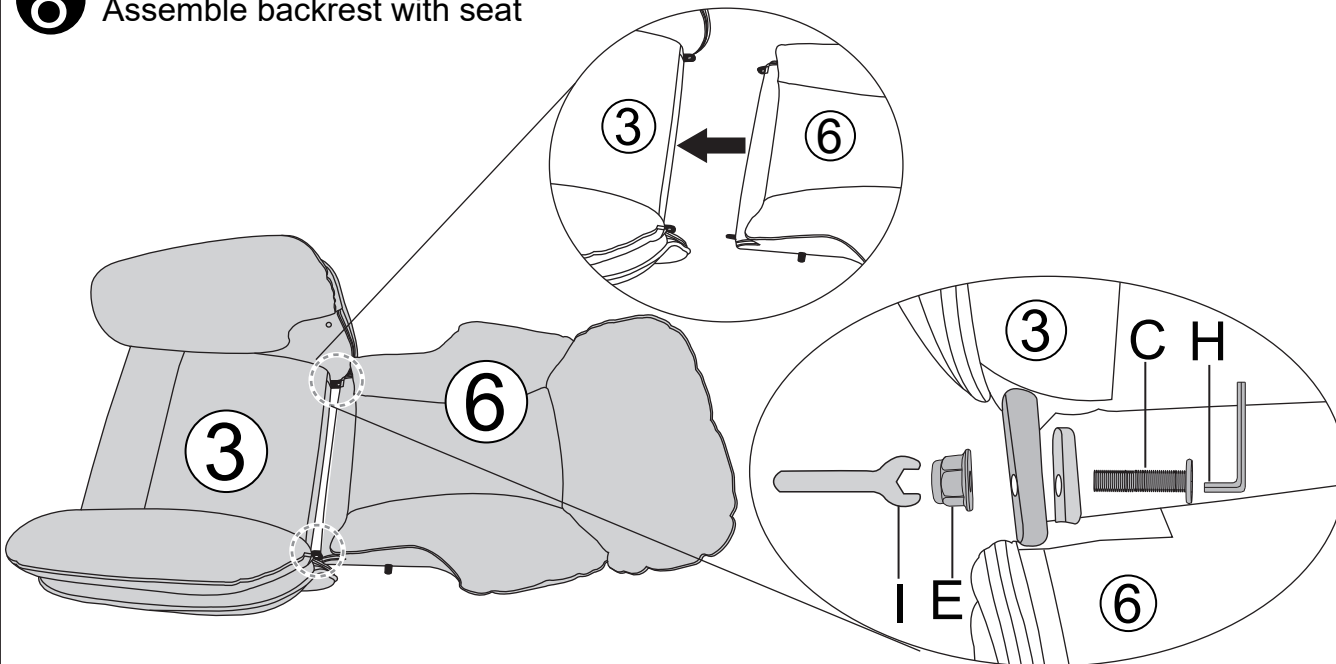

9

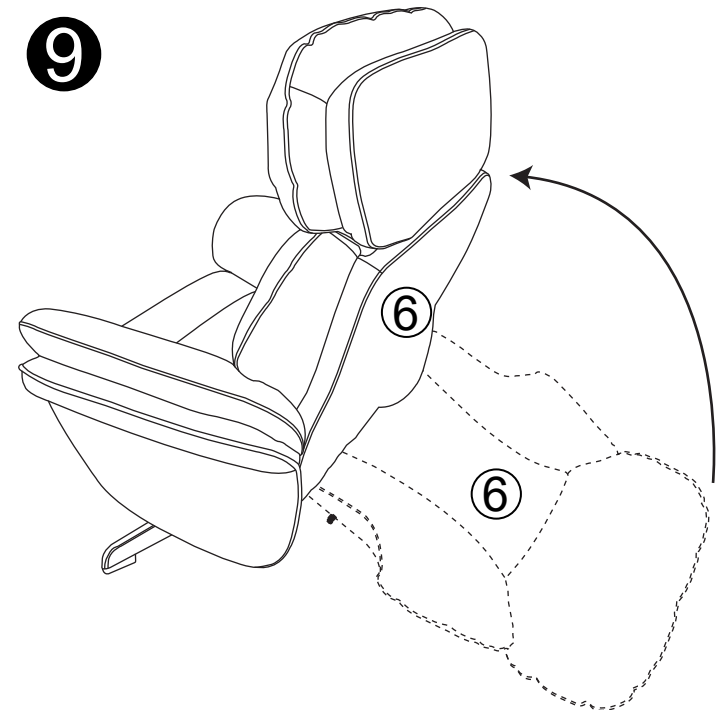

**10**

Assemble backrest with armrest, firstly, open armrest zipper, then let backrest screw hole link with armrest screw hole, then use screw and washer assemble

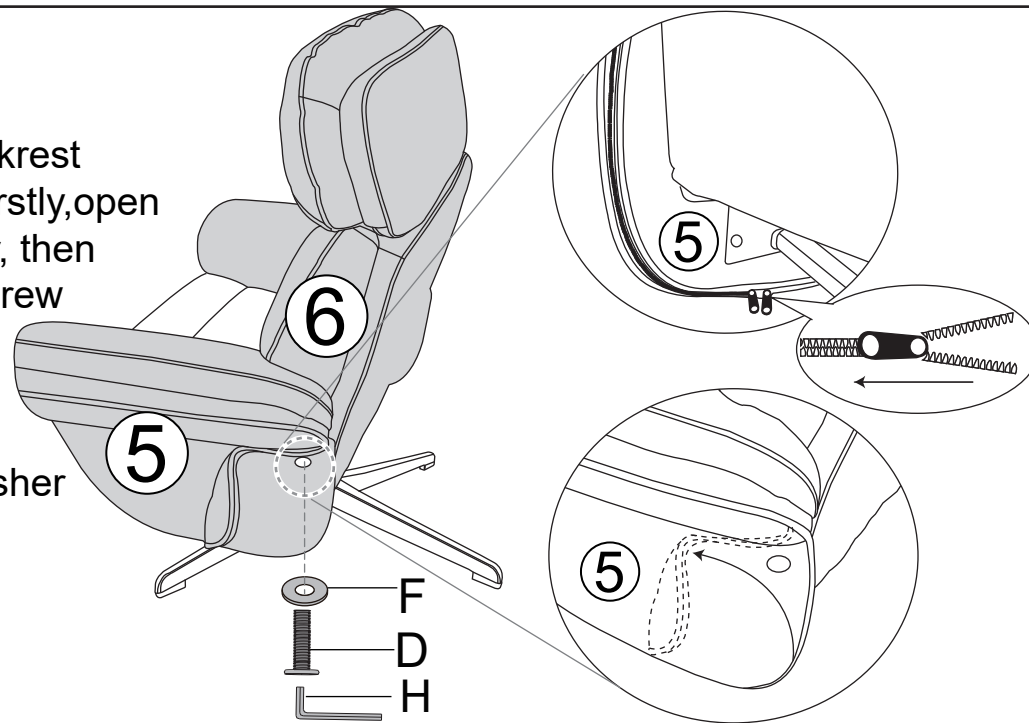

**11**

close armrest zipper

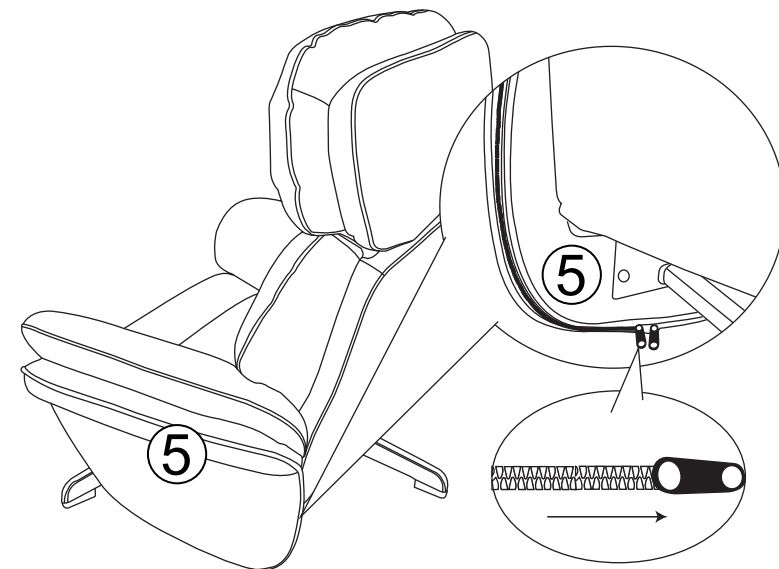

**12**

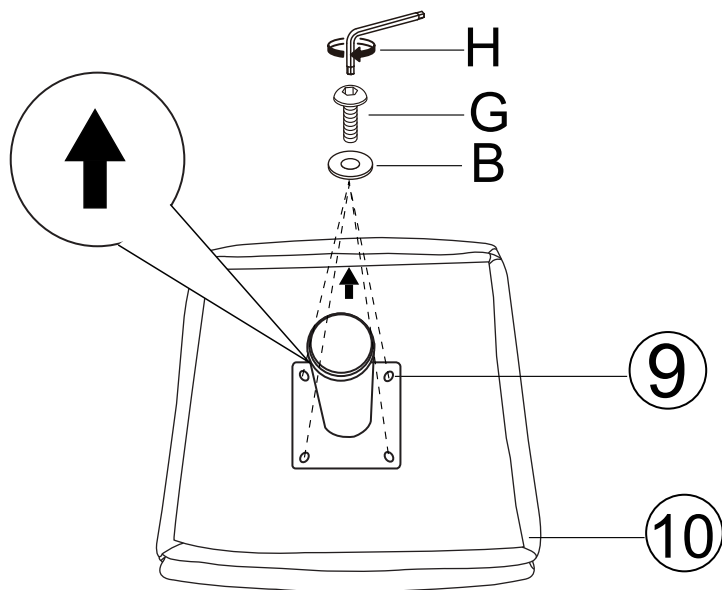

**13**

