

Ginny

Office Chair

Assembly & Care Instructions











1. Check you have received all parts listed on the component and hardware pages and the correct quantity of each . Beware that sometimes parts are packaged within the product so not immediately visible after opening . Please check the assembly section for more details . If anything is missing , stop assembling the product and contact our customer service team .
2. Check all parts are intact and undamaged . Any issues , stop assembling the product and contact our customer service team .

Safety advice.



Dear Customer

- **IMPORTANT** - The first step you need to take is to ensure your safety ! Please take the time to read and understand these instructions before assembling the product .
- Please keep these instructions for future reference .
- This item is intended for indoor use only - unless otherwise specified . Avoid exposure to humid conditions .
- Assembly to be carried out by a competent adult only .
- During assembly children should be kept away from the product due to possible risk of injury . The product may contain small parts that could also cause choking if swallowed .
- Products can be dangerous if incorrectly installed or assembled . Assembly should be carried out by a competent person and instructions followed . No liability will be accepted for damage or injury caused by incorrectly installed or assembled products .
- Never use an electric drill to assemble a product , as this can cause damage to parts .
- Regularly check all fastenings to ensure that they are properly tightened .
- Restrain children from climbing or playing on or around the product . Always consider where products are positioned to ensure children cannot get access to long cords or windows .
- Some products will be supplied with anti - tip kits which should always be used to secure the product to the wall and prevent tipping .
- Keep all plastic wrapping materials away from babies and children to avoid danger of suffocation .
- Ensure that all packaging is disposed of carefully and responsibly . Please recycle where possible .
- Once items are part or fully assembled , they are not returnable unless faulty .

Max weight limit	No . of people to assemble	Assembly difficulty	Time to assemble
			
110 KG	1 recommended	Easy	<30 minutes

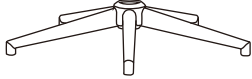
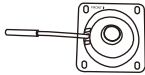
Ref	Visual	Qty
A		1
B		1
C		5
D		1

Ref	Visual	Qty
E		1
F		1

Ref	Visual	Qty
G	 <p>118005 M8x20mm</p>	4
G1	 <p>118006 M8x25mm</p>	4
L	 <p>118001 5#</p>	1

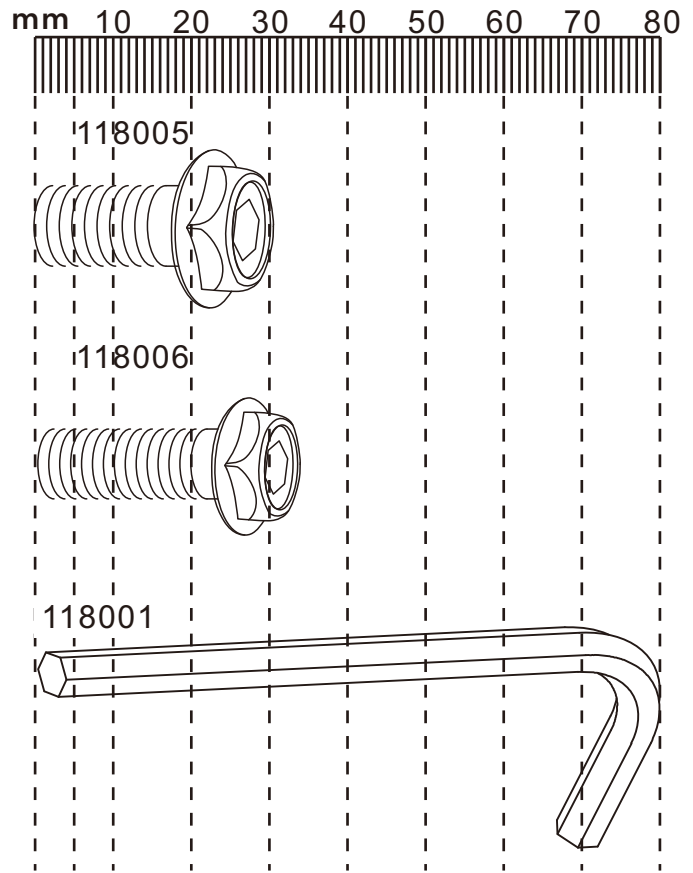

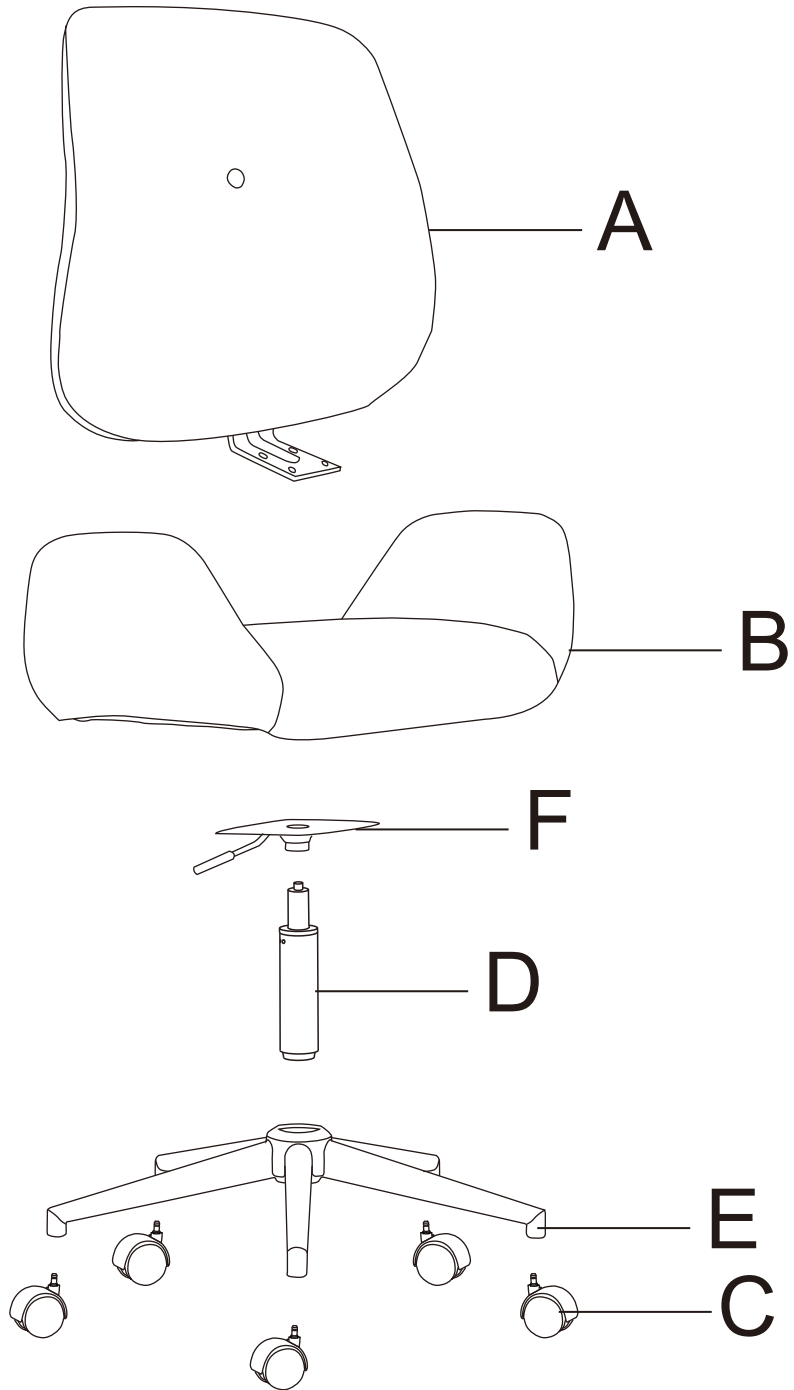

Assembly instructions.

	<p>ALWAYS lay each panel down on a clean and level area, ideally in the room of intended use, ensuring there is enough room to maneuver around the item.</p>
	<p>NEVER pull furniture into place as this causes damage to the internal structure and feet fixings. Always lift to move.</p>
	<p>NEVER flip your upholstery allowing corners to hit the floor as structural damage can be caused. Always turn gently.</p>

1

Please remove cap from top gaslift before assembling

C x 5	D x 1	E x 3

2

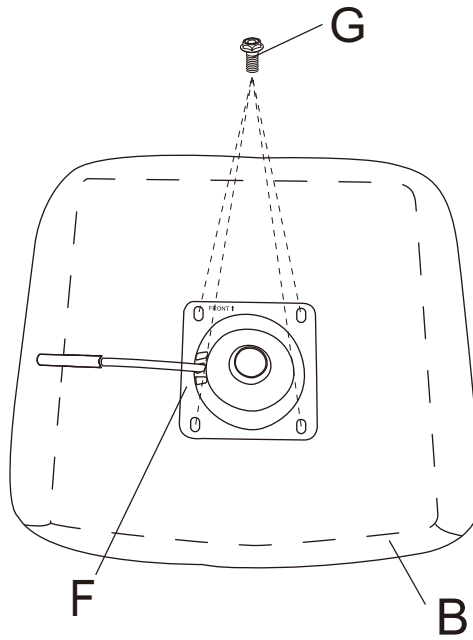

F x 1

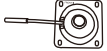

B



G x 4



3

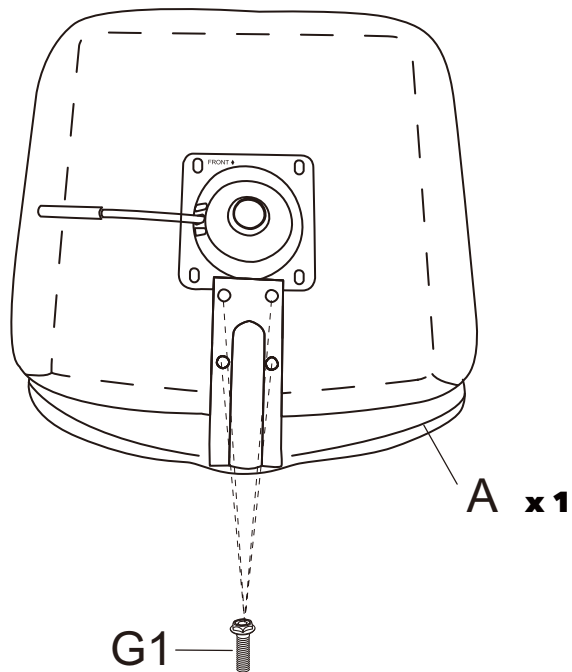

A x 1



G1 x 4



4

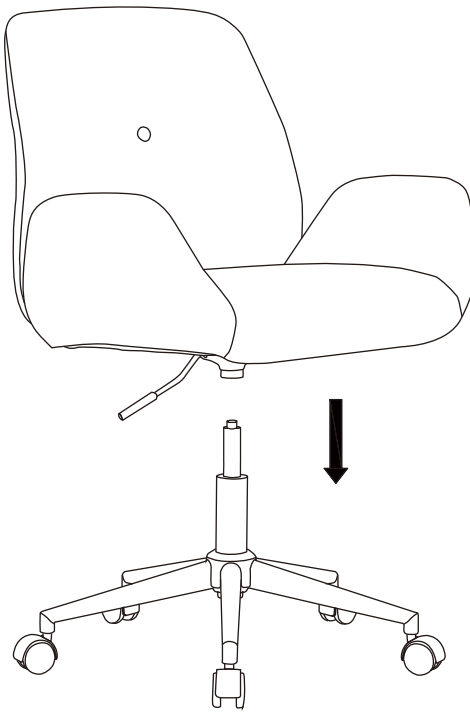

Final product.

5

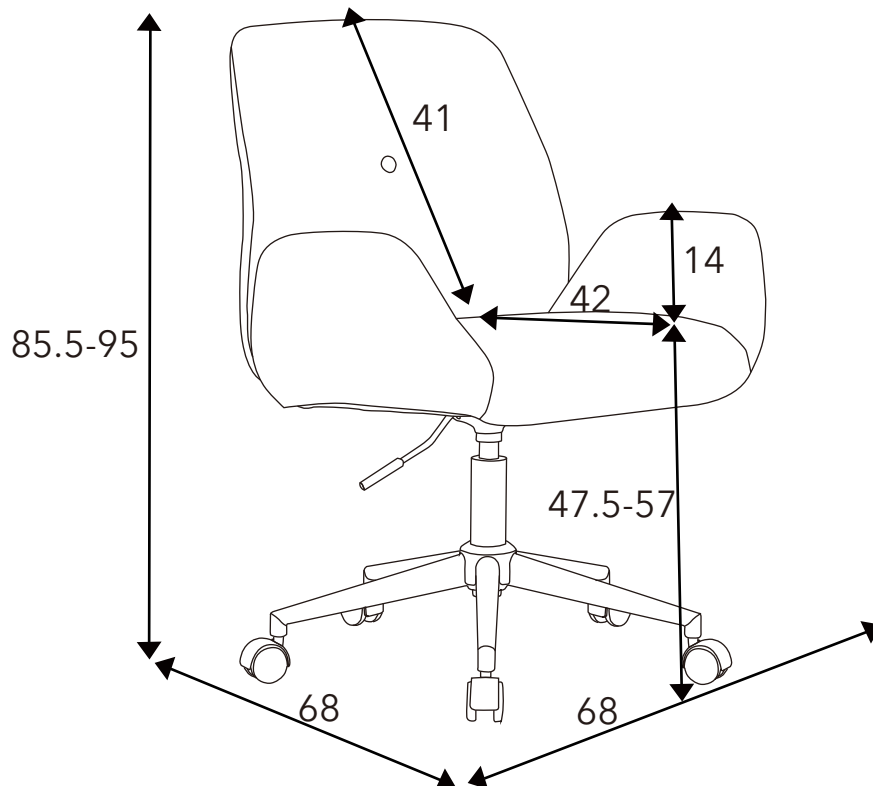

Customer service



If you have any issues with this product, you can call our Customer Service team on:
0345 165 6565 Monday to Friday **9am to 5:00pm**.

Alternatively, you can contact our team by Live Chat on: **Dunelm.com**

Monday to Friday 8am - 8:30pm

Saturdays 8am - 5:30pm

Sundays and bank holidays 9am - 4:30pm.



Dunelm (Soft Furnishings) Ltd. LE7 1AD
& Dunelm (Soft Furnishings) Holdings
Ltd. Dublin D12 WR25.