

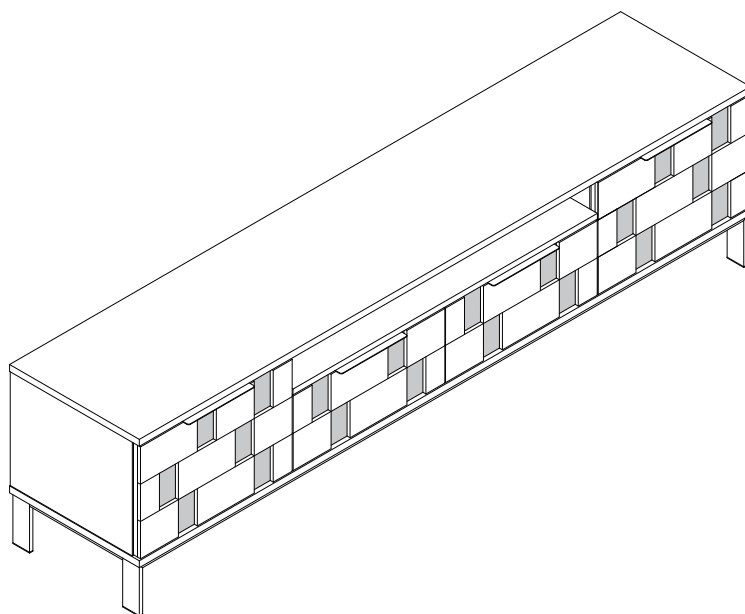

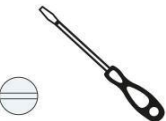



# Watson Extra Wide TV Unit

Assembly & Care Instructions







1. Check you have received all parts listed on the component and hardware pages and the correct quantity of each. Beware that sometimes parts are packaged within the product so not immediately visible after opening. Please check the assembly section for more details. If anything is missing, stop assembling the product and contact our customer service team.
2. Check all parts are intact and undamaged. Any issues, stop assembling the product and contact our customer service team.
3. Check you have the right tools for the job. Required tools which are not provided are listed below. If you are unsure of how to use these tools, please contact a professional tradesperson. We recommend Airtasker as an easy way to find trades people in your local area.







Tools required which are not included					
Flat head screwdriver	Cross head screwdriver	Spirit level	Tape measure	Pencil	Drill
					

## Safety advice.

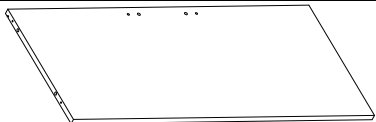
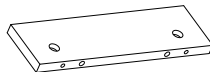
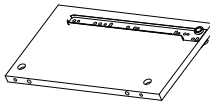
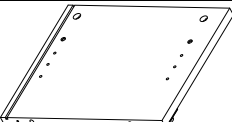
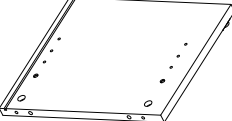
### Dear Customer

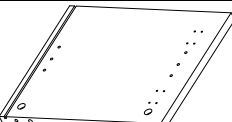
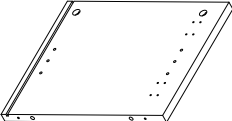
- **IMPORTANT** – The first step you need to take is to ensure your safety! Please take the time to read and understand these instructions before assembling the product.
- Please keep these instructions for future reference.
- This item is intended for indoor use only – unless otherwise specified. Avoid exposure to humid conditions.
- Assembly to be carried out by a competent adult only.
- During assembly children should be kept away from the product due to possible risk of injury. The product may contain small parts that could also cause choking if swallowed.
- Products can be dangerous if incorrectly installed or assembled. Assembly should be carried out by a competent person and instructions followed. No liability will be accepted for damage or injury caused by incorrectly installed or assembled products.
- Never use an electric drill to assemble a product, as this can cause damage to parts.
- Regularly check all fastenings to ensure that they are properly tightened.
- Restrain children from climbing or playing on or around the product. Always consider where products are positioned to ensure children cannot get access to long cords or windows.
- Some products will be supplied with anti – tip kits which should always be used to secure the product to the wall and prevent tipping.
- Keep all plastic wrapping materials away from babies and children to avoid danger of suffocation.
- Ensure that all packaging is disposed of carefully and responsibly. Please recycle where possible.
- Once items are part or fully assembled, they are not returnable unless faulty.

Max weight limit	No. of people to assemble	Assembly difficulty	Time to assemble
			
60 KG	2 recommended	Medium	30 mins-1 hour





Ref	Part	Visual	Qty
<b>1</b>	Middle shelf (91.5×39×1.5cm)		<b>1</b>
<b>2</b>	Back support panel (29×8.2×1.5cm)		<b>1</b>
<b>3</b>	Middle vertical partitional panel (35.2×20.1×1.5cm)		<b>1</b>
<b>4</b>	Left vertical partitional panel (36.7×29.8×1.5cm)		<b>1</b>
<b>5</b>	Right vertical partitional panel (36.7×29.8×1.5cm)		<b>1</b>
<b>6</b>	Back panel (92.3×20.8×0.27cm)		<b>1</b>
<b>7</b>	Left side panel (36.7×29.8×1.5cm)		<b>1</b>
<b>8</b>	Right side panel (36.7×29.8×1.5cm)		<b>1</b>
<b>9</b>	Base panel (183.7×39×1.8cm)		<b>1</b>
<b>10</b>	Metal leg (182.7×13.5×5cm)		<b>2</b>
<b>11</b>	Metal bar (28×2×1cm)		<b>2</b>
<b>12</b>	Metal support leg (12×5×5cm)		<b>1</b>

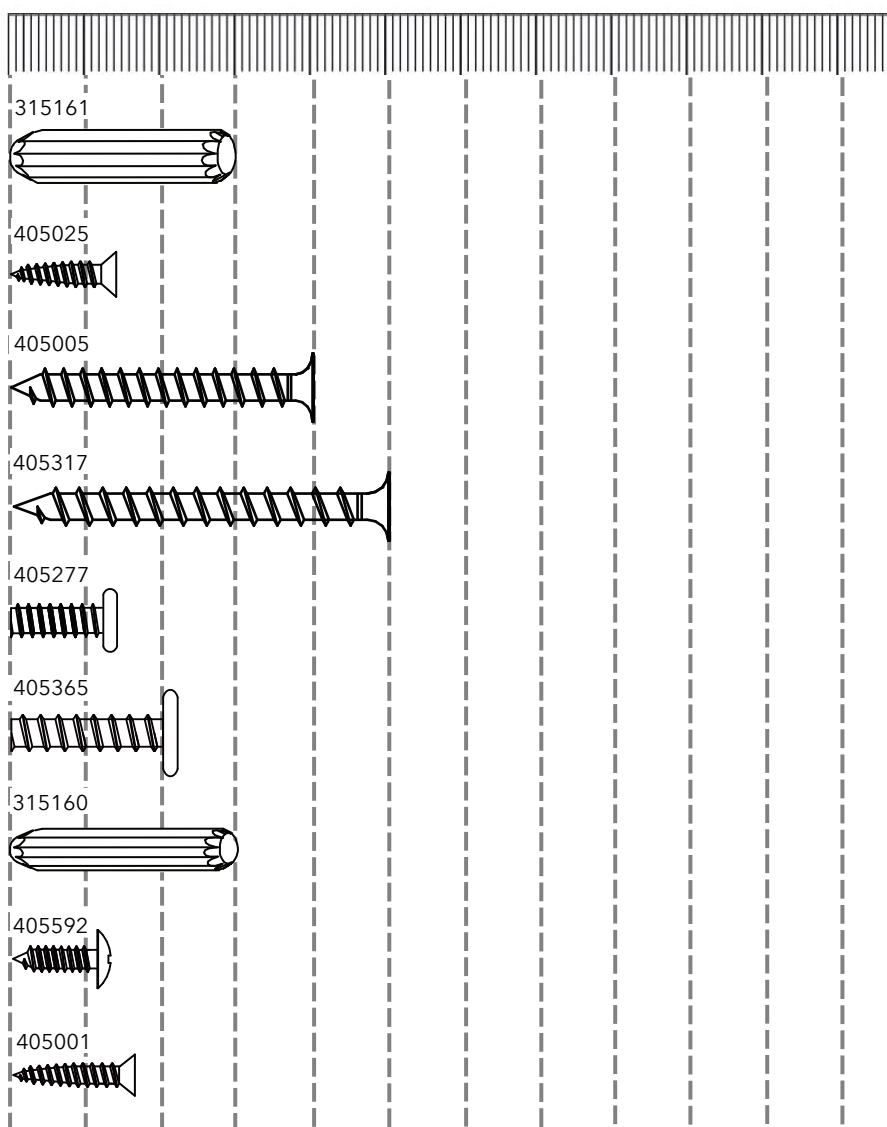

Ref	Part	Visual	Qty
<b>13</b>	Back panel (43.7×30.5×0.27cm)		<b>2</b>
<b>14</b>	Top panel (183.7×39×1.8cm)		<b>1</b>
<b>15</b>	Left door panel (45.6×29.1×2.1cm)		<b>1</b>
<b>16</b>	Right door panel (45.6×29.1×2.1cm)		<b>1</b>
<b>17</b>	Shelf (42.8×35×1.5cm)		<b>2</b>
<b>18</b>	Drawer left side panel (34×14×1.2cm)		<b>2</b>
<b>19</b>	Drawer right side panel (34×14×1.2cm)		<b>2</b>
<b>20</b>	Drawer back panel (40.1×14×1.2cm)		<b>2</b>
<b>21</b>	Drawer base panel (40.9×33.5×0.27cm)		<b>2</b>
<b>22</b>	Left drawer front panel (45.6×19.4×2.1cm)		<b>1</b>
<b>23</b>	Right drawer front panel (45.6×19.4×2.1cm)		<b>1</b>

mm 10 20 30 40 50 60 70 80 90 100 110

Ref	Hardware & dimension (mm)	Qty
<b>C</b>	Wooden Dowel M8×30mm	<b>28</b>
<b>D</b>	Screw M3.5×14mm	<b>24</b>
<b>E</b>	Screw M5×40mm	<b>14</b>
<b>F</b>	Screw M5×50mm	<b>10</b>
<b>G</b>	Bolt M6×12mm	<b>4</b>
<b>H</b>	Bolt M6×20mm	<b>20</b>
<b>I</b>	Wooden Dowel M6×30mm	<b>8</b>
<b>J</b>	Screw M4×12mm	<b>12</b>
<b>K</b>	Screw M3x16mm	<b>12</b>

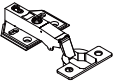
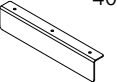

Ref	Dimensions	Visual	Qty
<b>A</b>	7×37mm	 <p>405037</p>	<b>20</b>
<b>B</b>	15×9.6mm	 <p>405448</p>	<b>20</b>
<b>L</b>	N/A	 <p>407034</p>	<b>12</b>
<b>M</b>	N/A	 <p>406376</p>	<b>1</b>
<b>N</b>	N/A	 <p>406362</p>	<b>1</b>

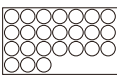
Ref	Dimensions	Visual	Qty
<b>O</b>	N/A	 <p>406341</p>	<b>4</b>
<b>P</b>	N/A	 <p>404323</p>	<b>4</b>
<b>Q</b>	N/A	 <p>408111</p>	<b>8</b>
<b>R</b>	N/A	 <p>408182</p>	<b>24</b>

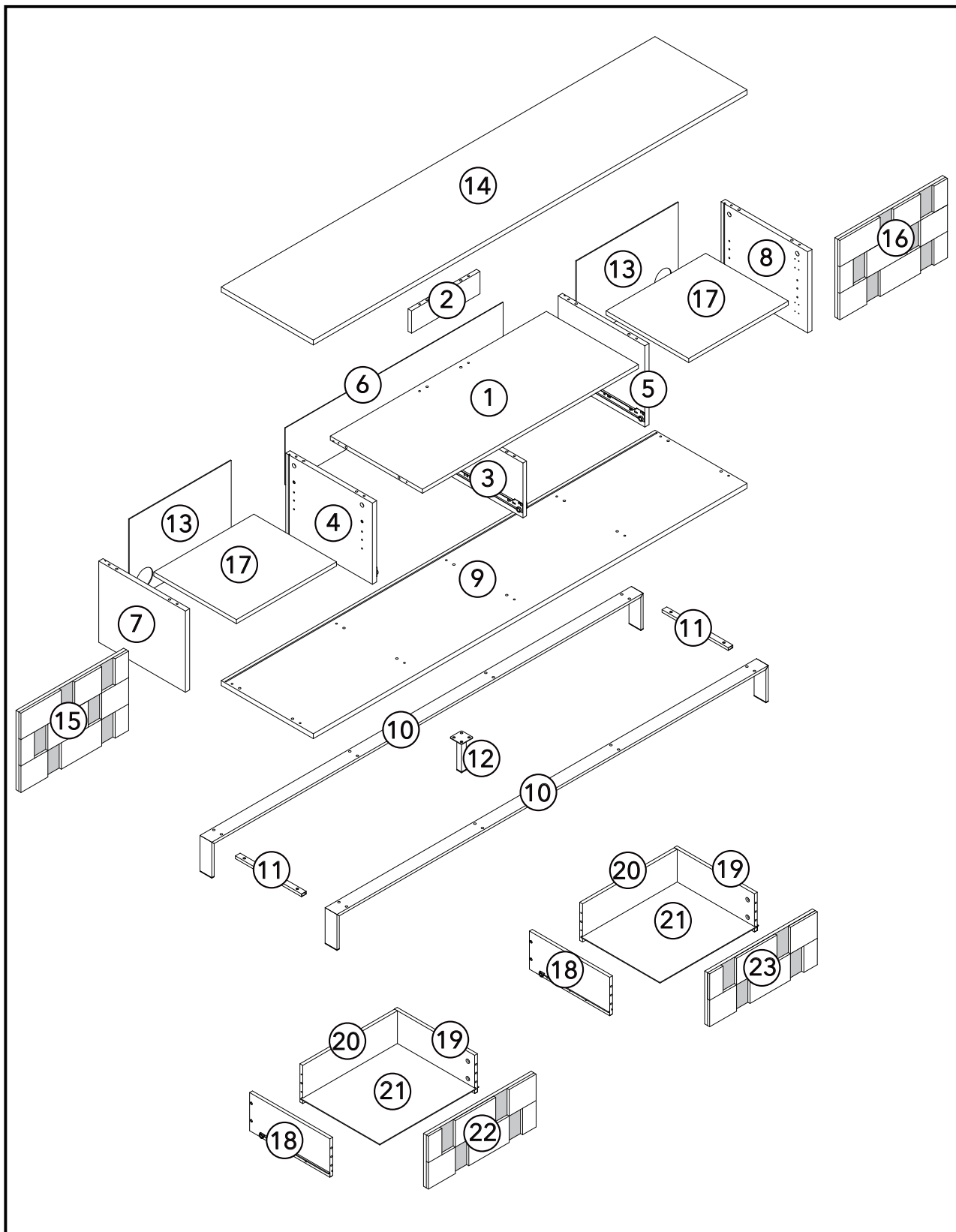

	<p><b>ALWAYS</b> lay each panel down on a clean and level area, ideally in the room of intended use, ensuring there is enough room to maneuver around the item.</p>
	<p><b>NEVER</b> pull furniture into place as this causes damage to the internal structure and feet fixings. Always lift to move.</p>
	<p><b>NEVER</b> flip your upholstery allowing corners to hit the floor as structural damage can be caused. Always turn gently.</p>

1

**A x 2**

**CAM-LOCK**  
Tighten until shoulder is flush with panel. Do not overtighten or undertighten (see example below)

Shoulder  
**NO GAP**

**2**

**E**

5 x 40mm

**F**

5 x 50mm

**C**

8 x 30mm

**I**

6 x 30mm

**C x 2**

**E x 2**

**3**

**C**

8 x 30mm

**I**

6 x 30mm

WHEN FITTING CAMS  
ENSURE STARTING POSITION IS CORRECT  
BEFORE YOU INSERT CONNECTING CAM-PILLAR  
TURN CLOCKWISE UNTIL SECURE

✓  
CORRECT

✗  
INCORRECT

**B x 2**

**C x 2**

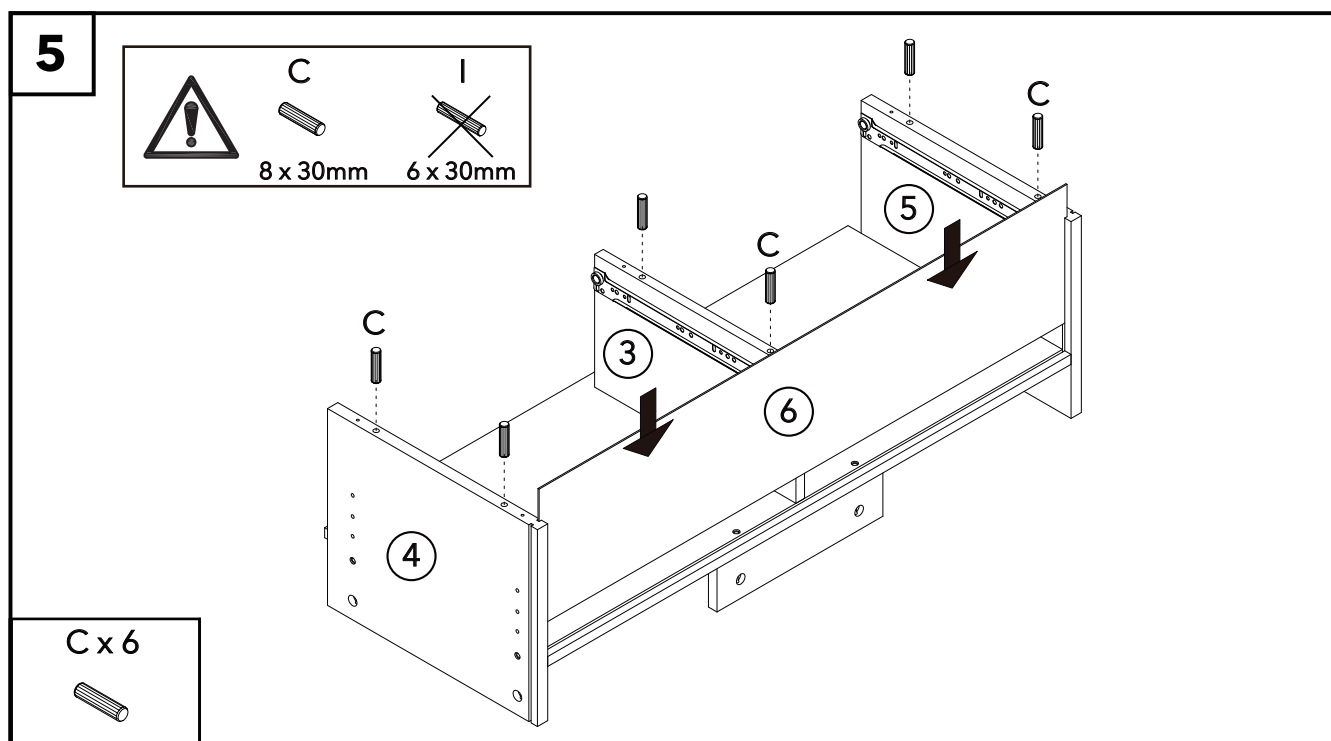
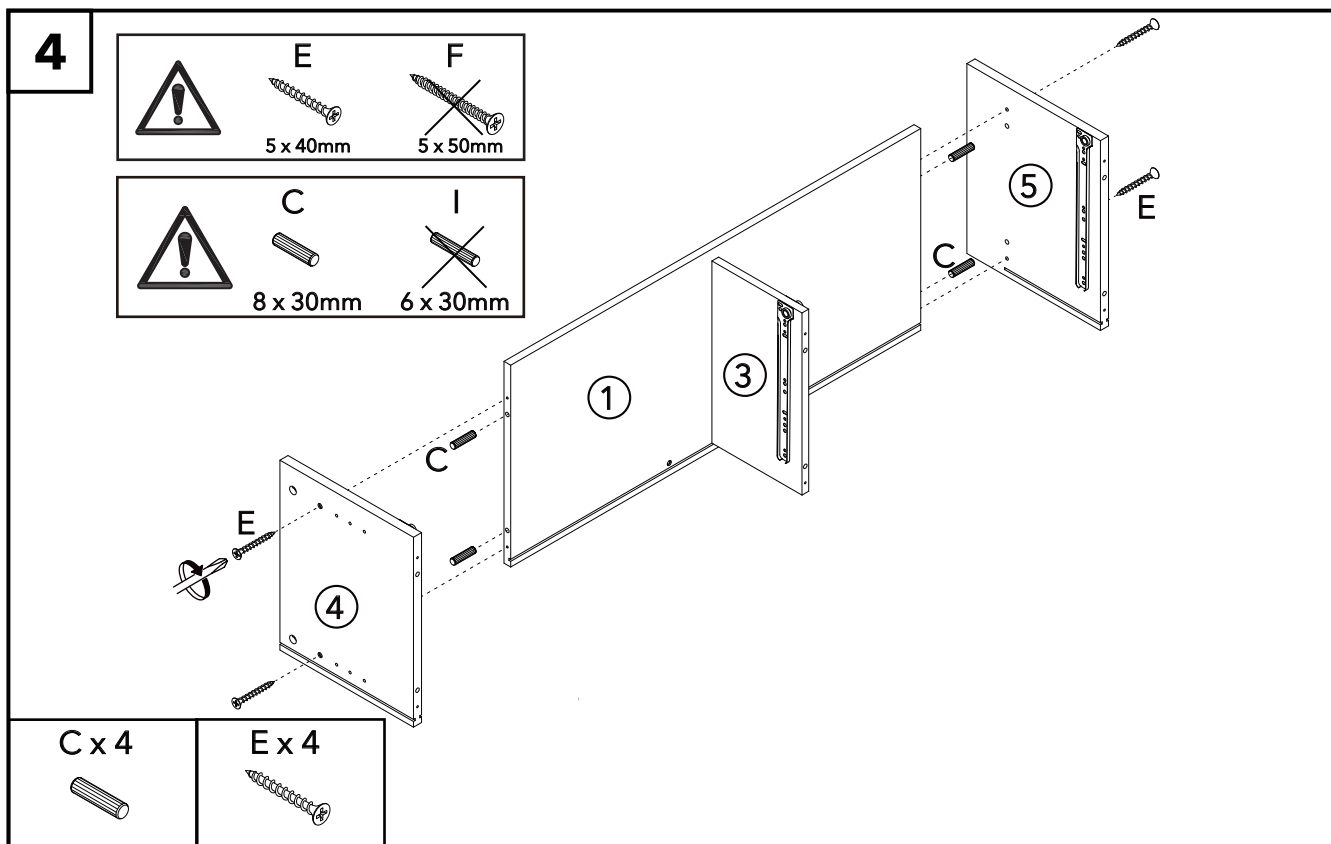

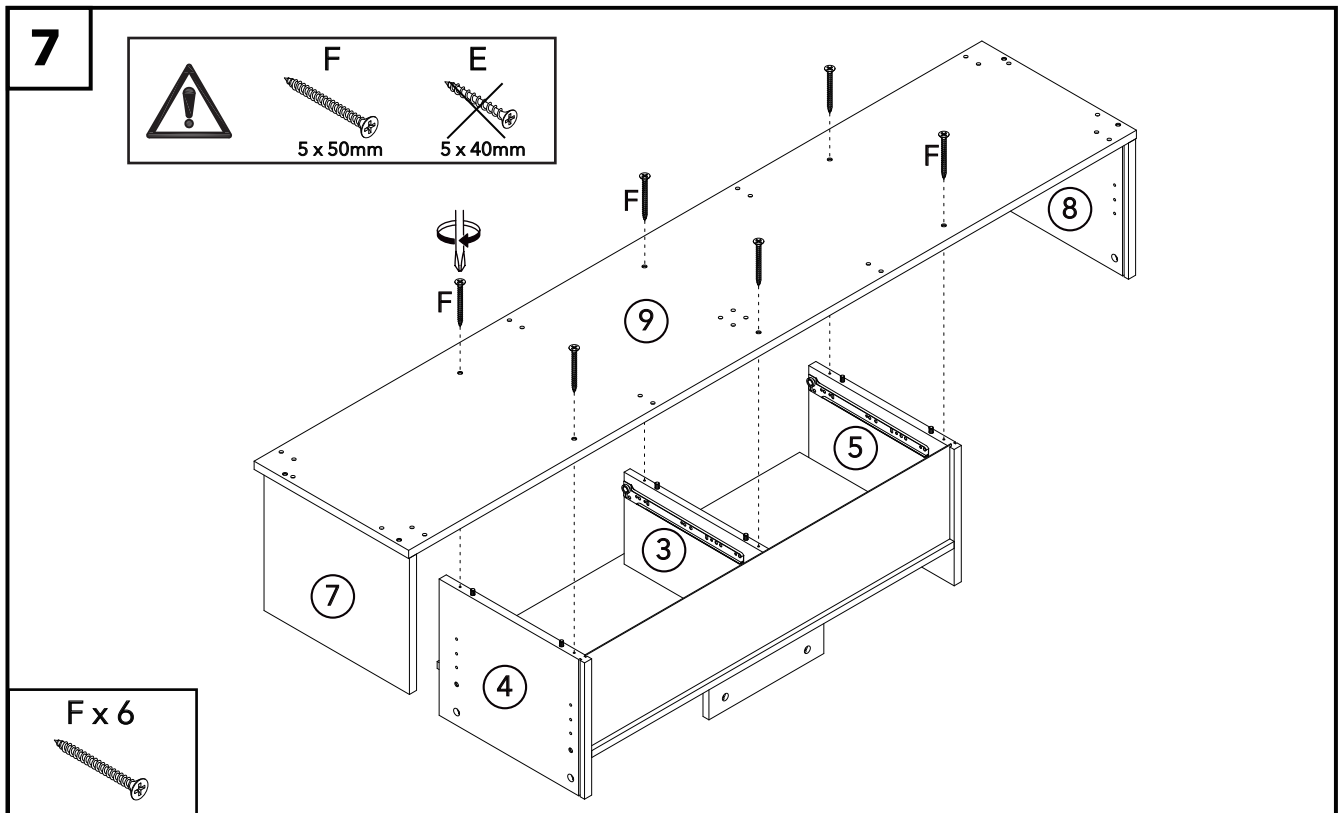
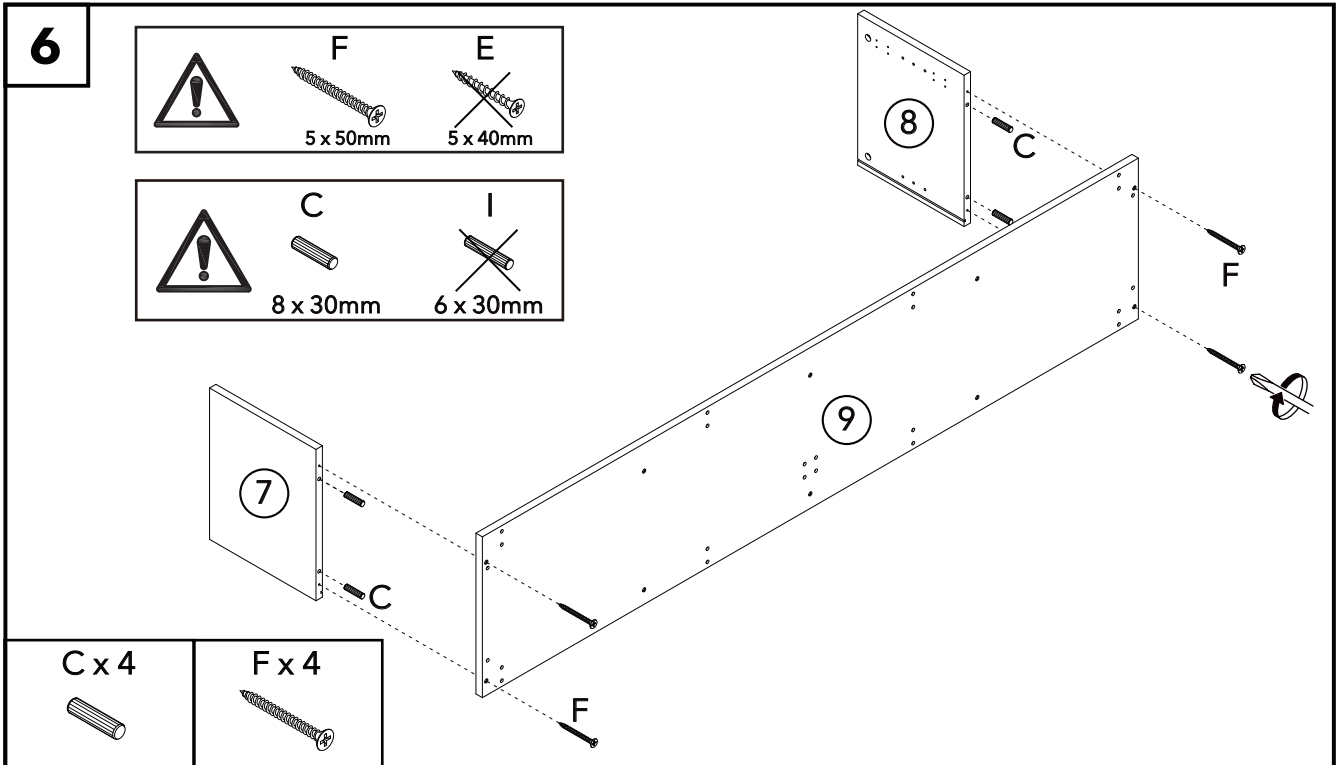

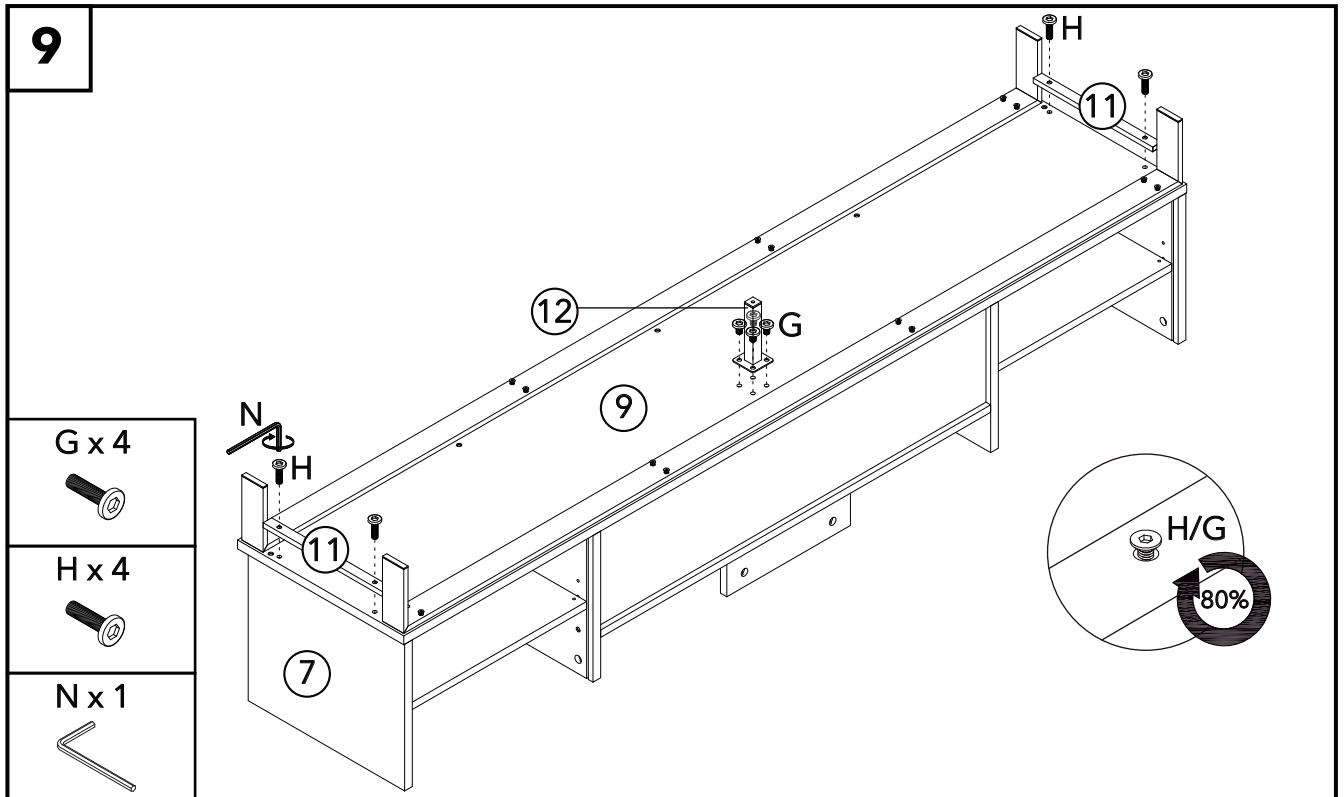
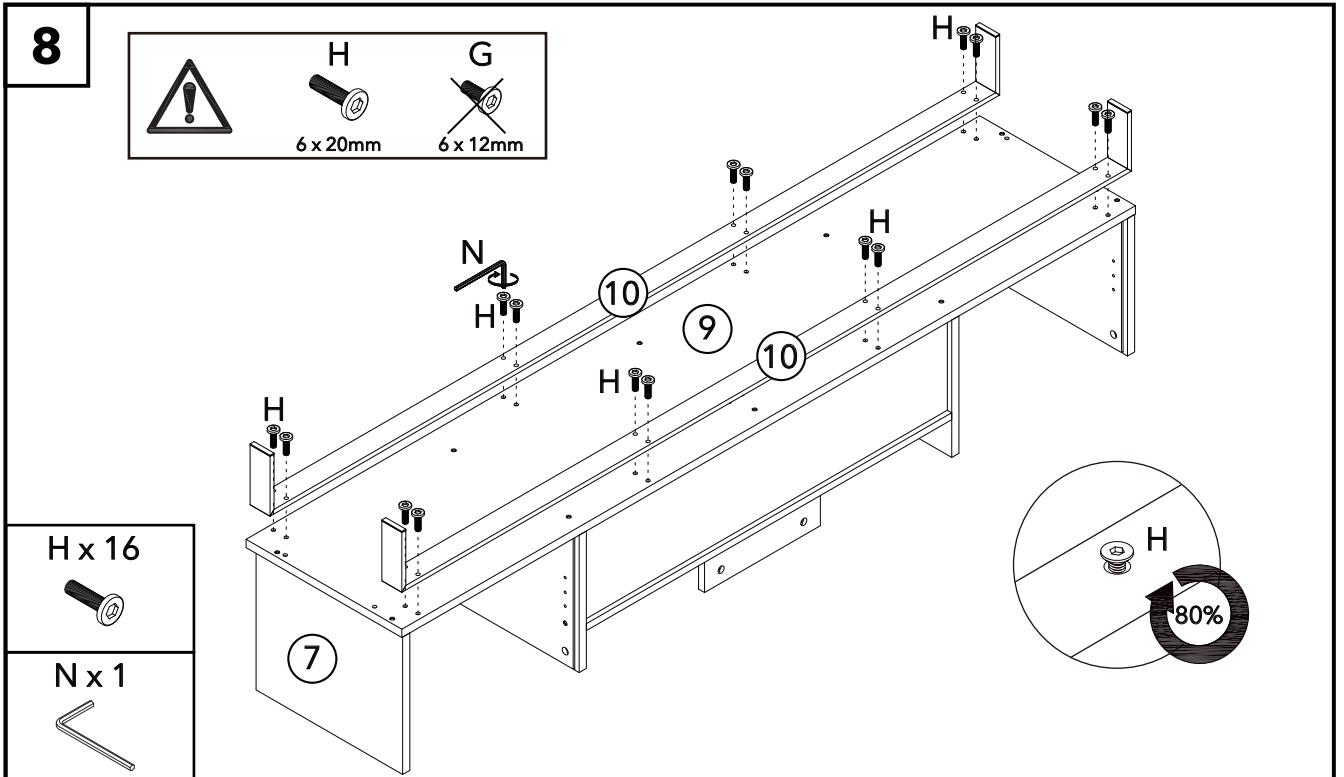



12

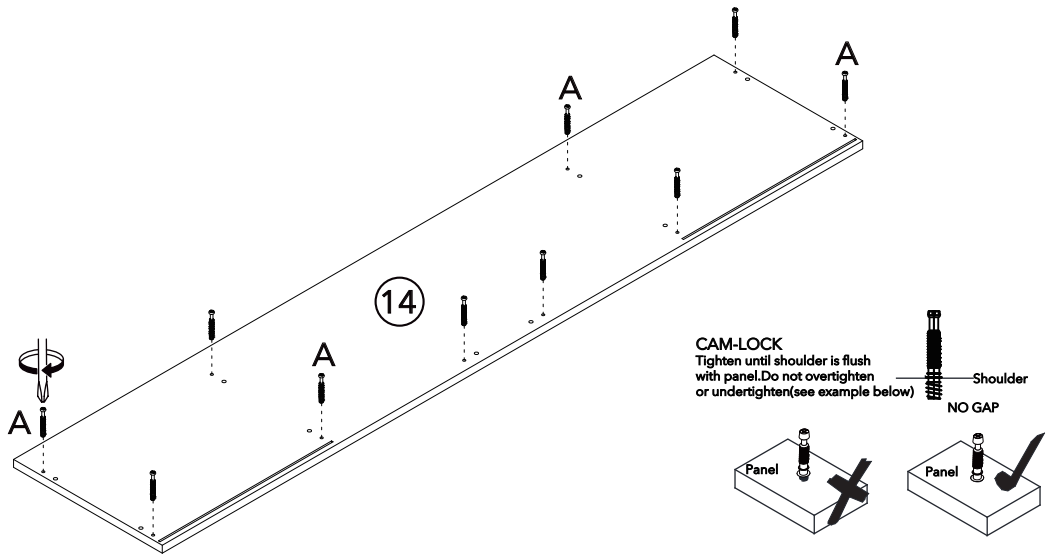

13

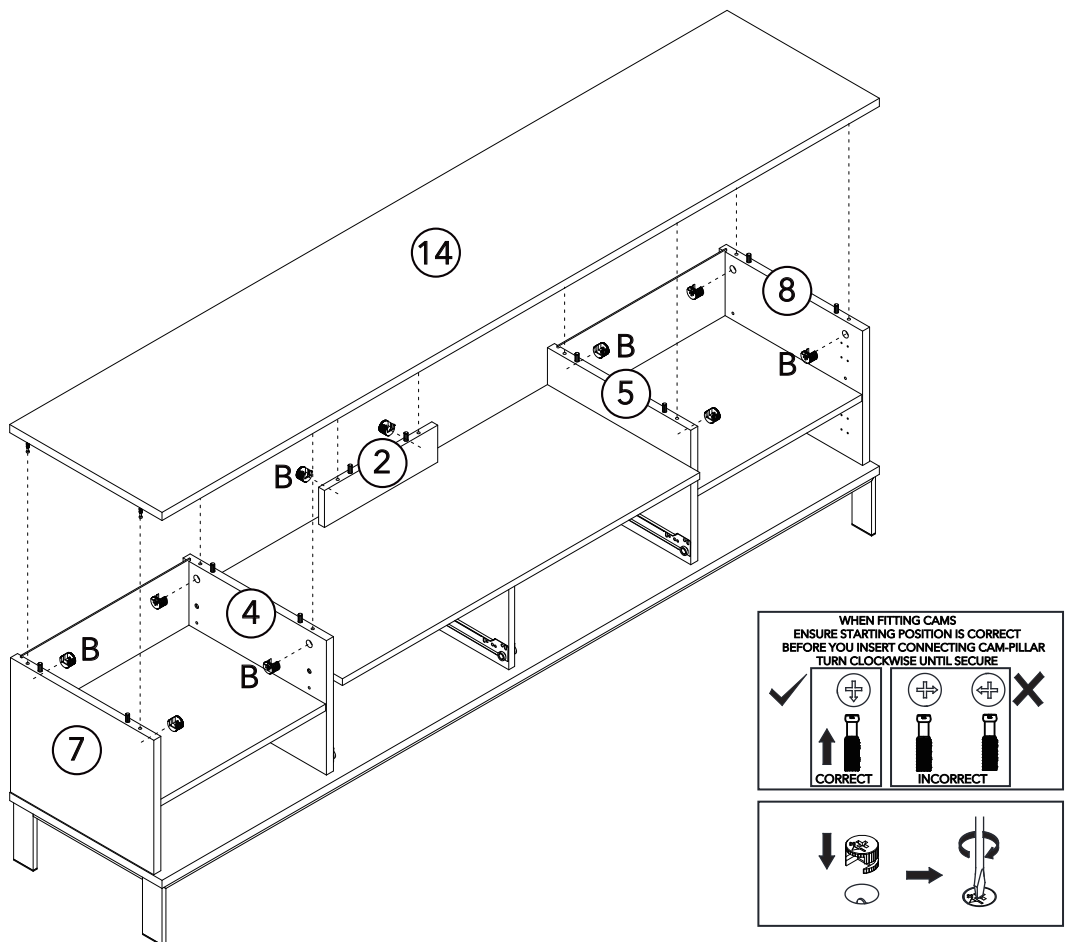

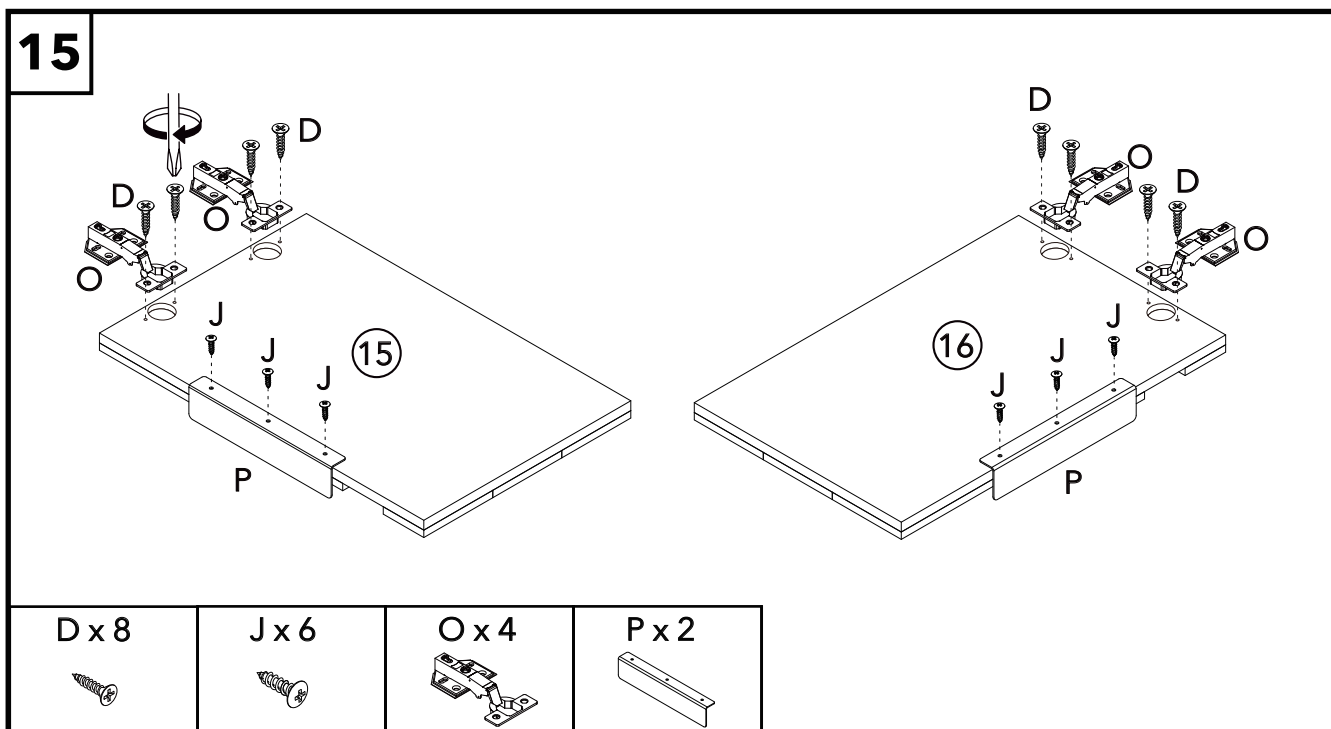
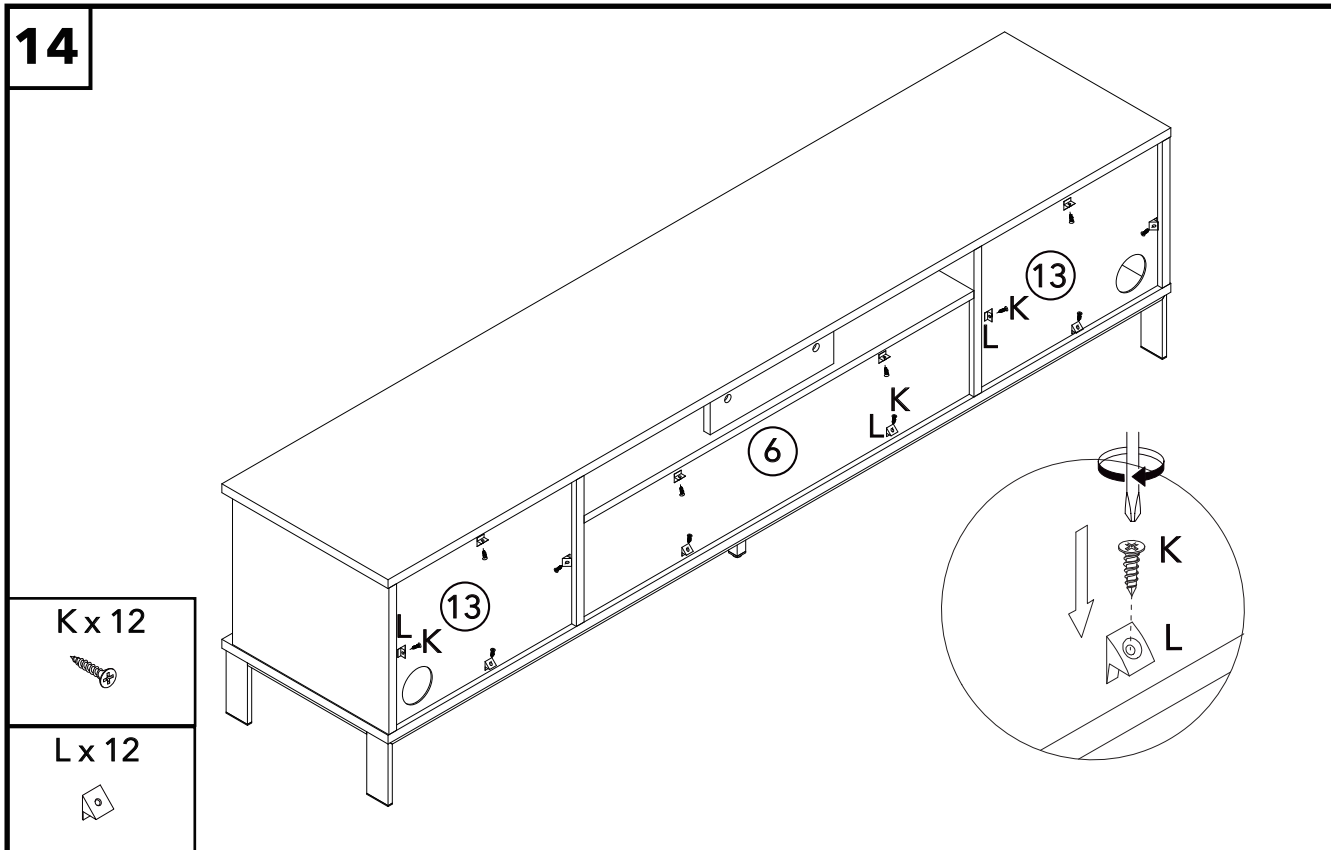

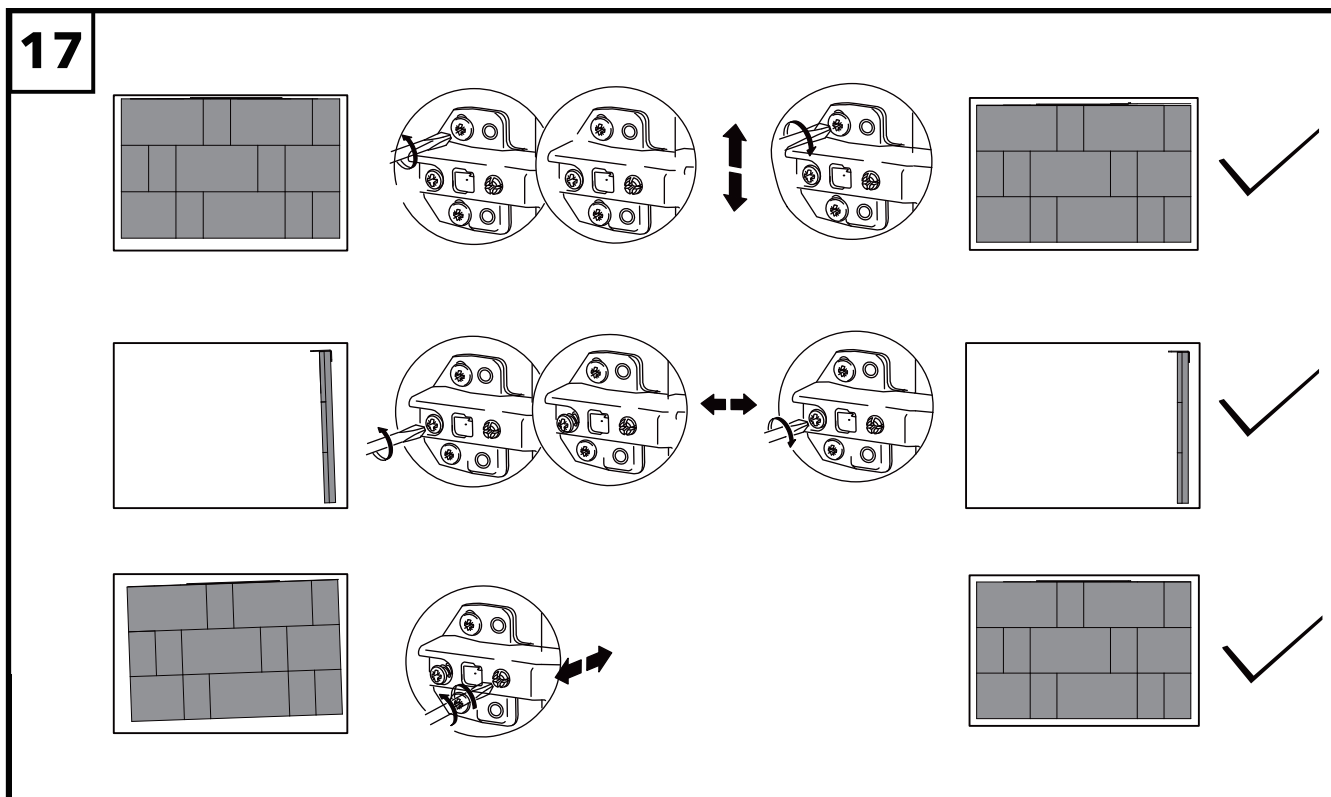
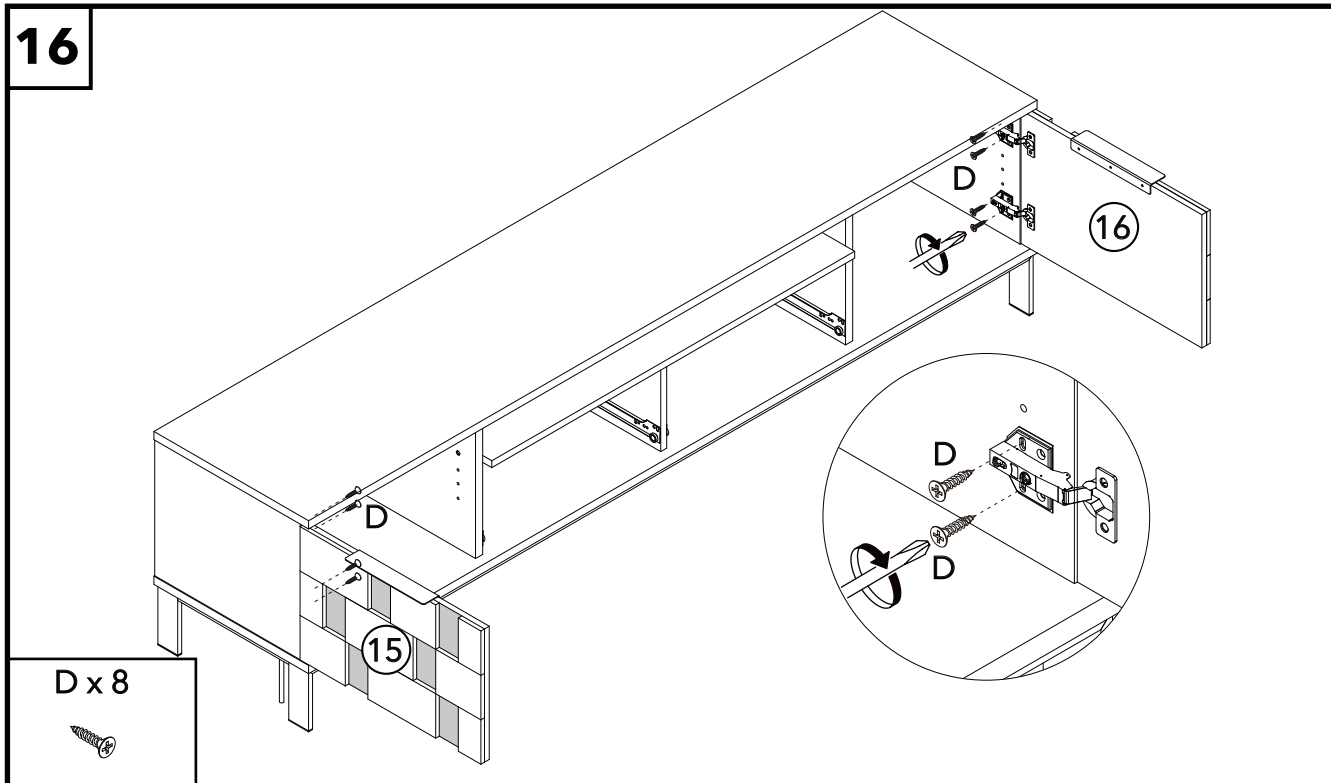

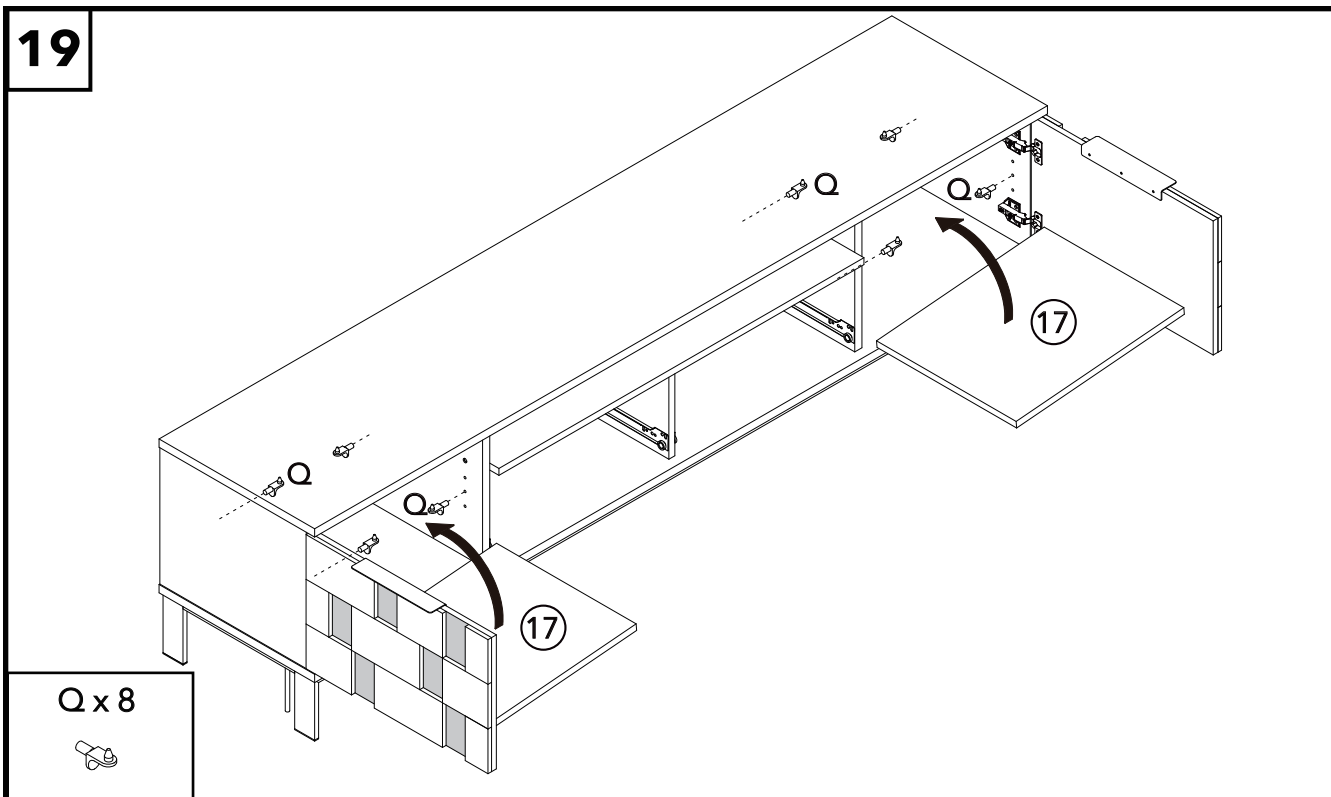
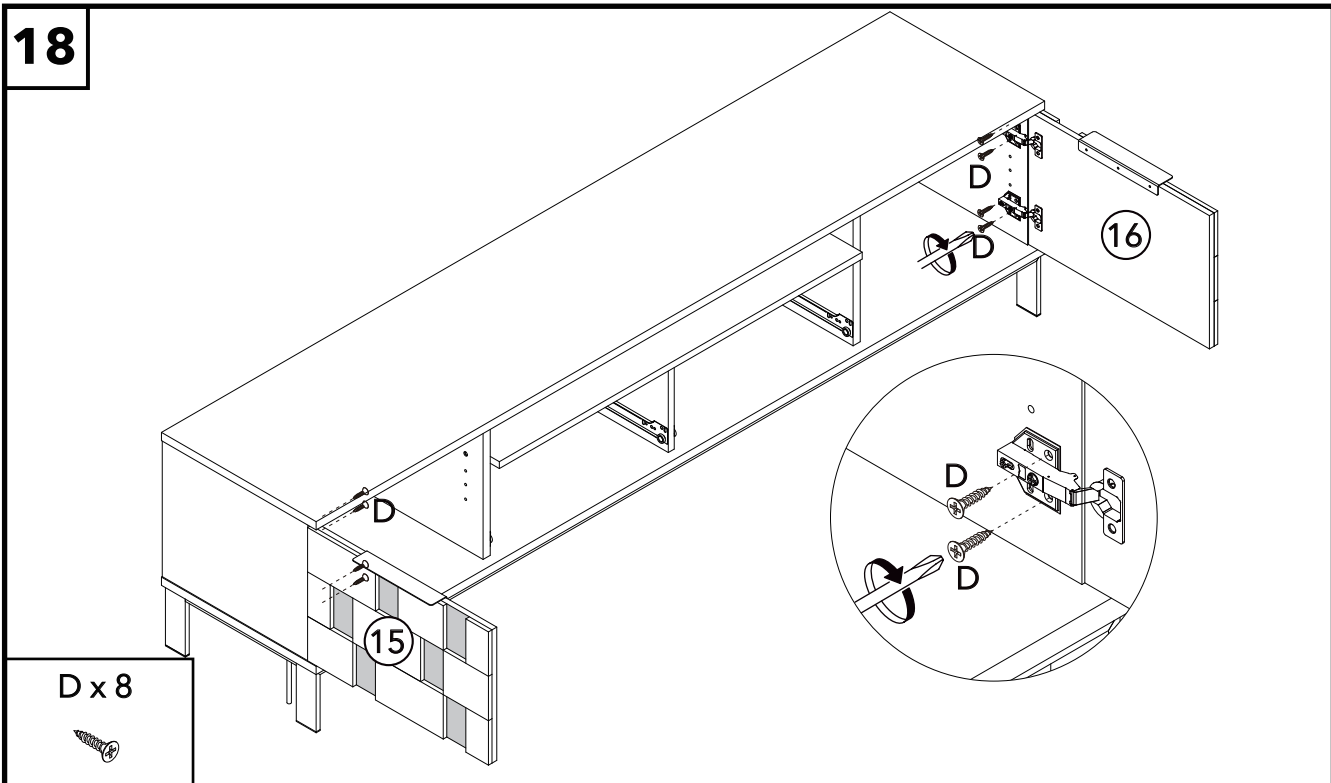

**20**

**E x 8**

**I x 4**

**21**

**A x 8**

**J x 6**

**P x 2**

**CAM-LOCK**  
Tighten until shoulder is flush with panel. Do not overtighten or undertighten (see example below)

Shoulder  
NO GAP

**22**

WHEN FITTING CAMS  
ENSURE STARTING POSITION IS CORRECT  
BEFORE YOU INSERT CONNECTING CAM-PILLAR  
TURN CLOCKWISE UNTIL SECURE

✓ CORRECT    ✗ INCORRECT

B x 8

l x 4

**23** 1. Use stickers (R) on all visible holes.

R x 24



## General furniture care.

---

- Uneven floors could give the impression that doors are out of alignment or that the furniture is wobbly. Be aware of this and compensate, if necessary, by adjusting the hinges or packing a corner to level the item. Please refer to the assembly instructions and adjust accordingly.
- If your furniture becomes stained, scratched, chipped or suffers other damage, we recommend professional help is sought to restore it. Please contact our customer services line for recommended agents.
- **DO** move items such as ornaments or coasters around periodically to allow the colour to mellow evenly.
- **DO** use mats and coasters to protect the surface from heat, liquids, or items that may cause scratches.
- **DO** ensure plastic or felt feet protectors are securely fitted into place on the feet and legs to avoid scratches.
- **DO** check fittings and fixings from time-to-time and tighten when necessary. Stop using the product if still unstable after all screws and bolts are tightened.
- **DO NOT** drag your furniture when moving it as this can damage joints. Always lift furniture into place.

## Specific material care.

---

### Foil Care

- **DO** avoid water or other liquids contacting scratches or chips as this can cause the surface to bubble and lift.
- **DO** only clean using a damp cloth and mild detergent. Aim to dust weekly with a soft, lint-free cloth or duster to prevent any build up of dirt.
- **DO** remove any spills immediately to avoid staining.
- **DO NOT** place directly in front of heat sources such as radiators or fires as timber can be affected by temperature and humidity which may cause cracking and warping.
- **DO NOT** in direct sunlight, as this will cause the colour to change quickly.
- **DO NOT** use bleach or abrasive cleaners.
- **DO NOT** use too much water when cleaning, the cloth should just be slightly damp.
- **DO NOT** use abrasive polish or silicon-based polishes as these can affect the finish over time.

---

If you have any issues with this product, you can call our Customer Service team on:  
**0345 165 6565** Monday to Friday **9am to 5:00pm**.

Alternatively, you can contact our team by Live Chat on: **Dunelm.com**  
**Monday to Friday 8am – 8:30pm**  
**Saturdays 8am – 5:30pm**  
**Sundays and bank holidays 9am – 4:30pm.**



**Dunelm (Soft Furnishings) Ltd. LE7 1AD**  
**& Dunelm (Soft Furnishings) Holdings**  
**Ltd. Dublin D12 WR25**