

AXEL BEDSIDE TABLE-OAK ASSEMBLY INSTRUCTIONS

Thank you for purchasing the AXEL BEDSIDE TABLE-OAK. Please read the instructions carefully to ensure safe operation of the product.

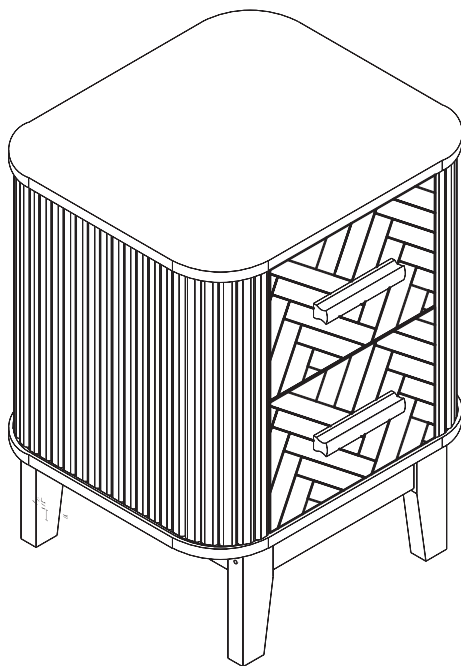

Size: L 450 X W 400 X H 580 mm
Colour : OAK

PLEASE READ this sheet prior to assembly to familiarise yourself with the various stages of construction.

Carefully open the pack supplied and check the contents against the parts and fittings check list. Do not destroy any of the packaging until you are certain that you have all the necessary parts for the assembly.

CAUTION: There are small components used in the construction of this unit. These loose items should be kept away from young children whilst assembling your unit to avoid the danger of choking hazards.

Tools Required

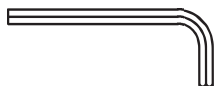

30 Mins
Set Up

AXEL BEDSIDE TABLE-OAK ASSEMBLY INSTRUCTIONS

IMPORTANT - READ CAREFULLY - RETAIN THESE INSTRUCTIONS FOR FUTURE REFERENCE.

INFORMATION

- Due to the size of this product we recommend that it is assembled in the room intended for use.
- When you are ready to start, make sure that you have the right tools, plenty of space and a clean, dry area for assembly.
- Unwarp all packaging materials and place the components on top of the carton box or on a clean floor to prevent it from scratching.
- Check the pack and make sure you have all the parts listed .
- Ensure that this product is fully assembled as illustrated before use.
- Check all screws or bolts are tightened and inspect regularly.
- This product should only be used on firm,level ground.
- Keep small parts out of reach of children.
- Make sure the legs remain in contact with the ground.
- Tools not included.

WARNING

- Keep small parts out of reach of children.
- Make sure the legs remain in contact with the ground.
- DO NOT use power tools to construct this product.
- DO NOT tighten screws until fully assembled.
- DO NOT over tighten screws or bolts.
- DO NOT use this product if parts are missing, damaged or worn.
- DO NOT stand on the product.
- DO NOT place very hot or very cold items on the surface unless adequately thick tablemats are use to prevent such items damaging your table top.
- Incorrect installation could lead to injury, take care following instruction.
- Take care when adjusting positions to avoid trapping of body parts.
- We recommend the use of wall safety bracket provided for safety reasons.

CARE INFORMATION

- Never use scourers, abrasives or chemical cleaners.
- To clean wipe with a sponge and warm soapy water. Do not use solvent based cleaners or detergents as they can bleach or damage the product.

AXEL BEDSIDE TABLE-OAK

ASSEMBLY INSTRUCTIONS

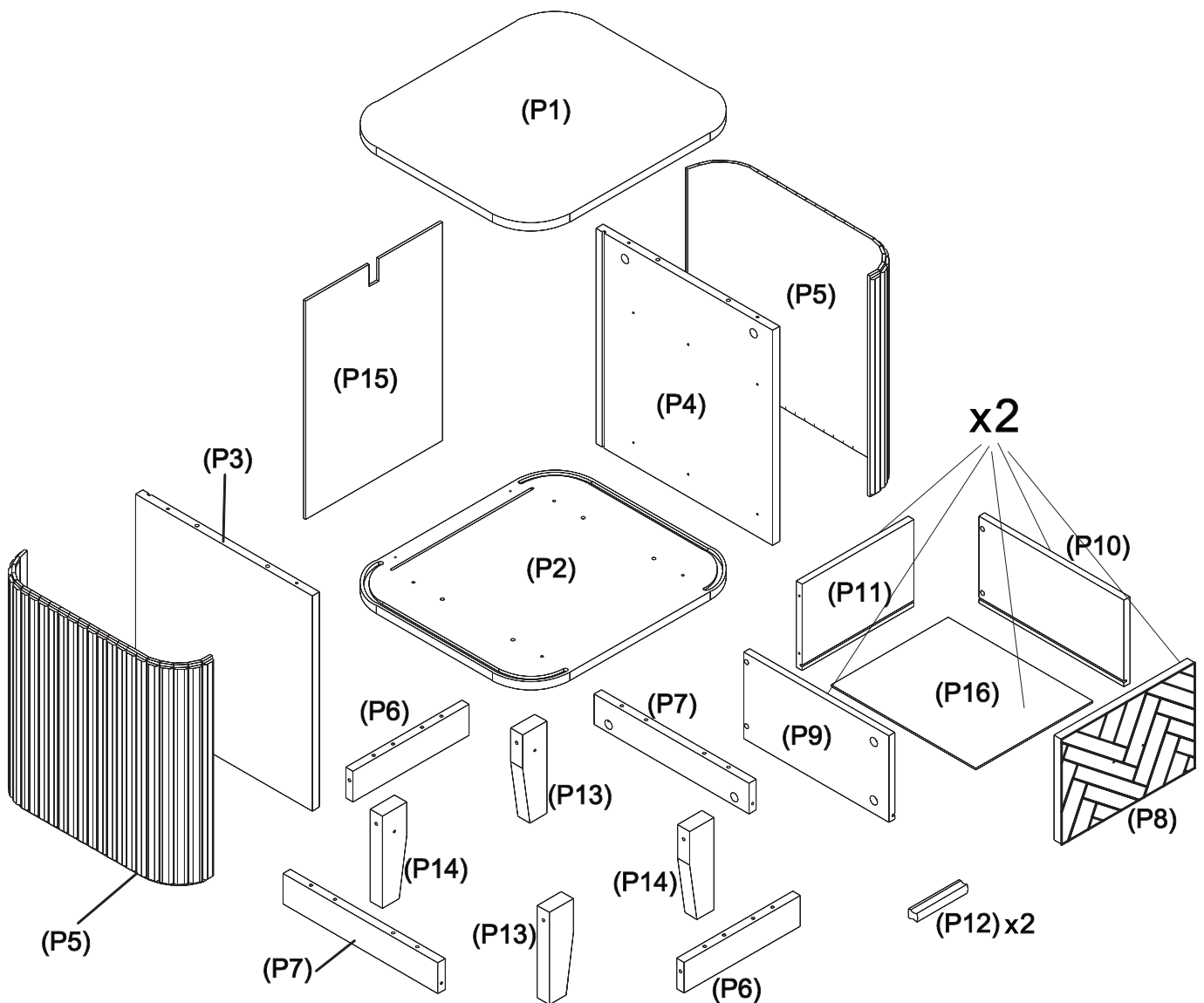

Please check the pack contents before assembling the product. If any components are missing, please contact your retailer. The fittings pack contains small items that should be kept away from small children.

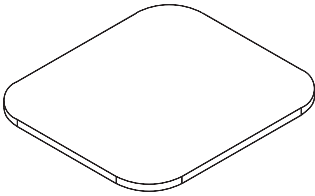
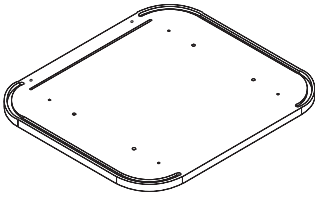
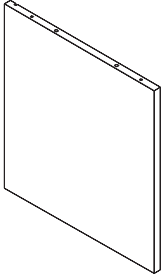
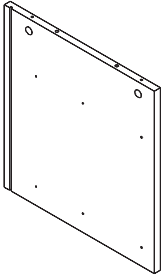
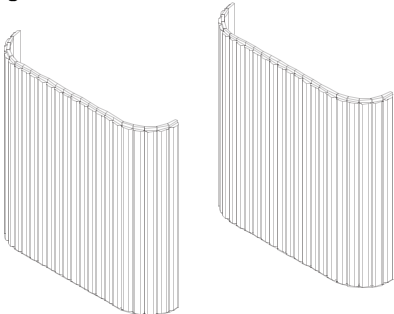
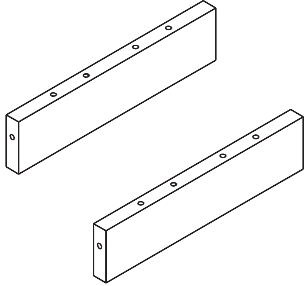
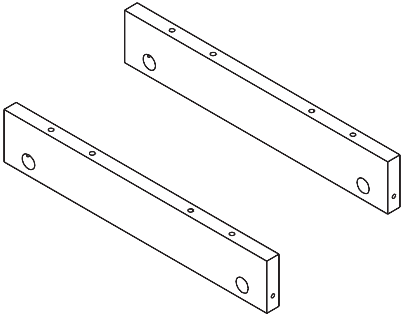
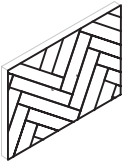
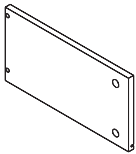

AXEL BEDSIDE TABLE-OAK ASSEMBLY INSTRUCTIONS

<p>P1</p> 	<p>P2</p> 	<p>P3</p> 
<p>TOP PANEL 1PC Carton No: 1</p>	<p>BOTTOM PANEL 1PC Carton No: 1</p>	<p>LEFT SIDE PANEL 1PC Carton No: 1</p>
<p>P4</p> 	<p>P5</p> 	<p>P6</p> 
<p>RIGHT SIDE PANEL 1PC Carton No: 1</p>	<p>FLUTED RAILS 2PCS Carton No: 1</p>	<p>BOTTOM FRONT/BACKRAILS 2PCS Carton No: 1</p>
<p>P7</p> 	<p>P8</p> 	<p>P9</p> 
<p>BOTTOM LEFT/RIGHT RAILS 2PCS Carton No: 1</p>	<p>DRAWER FRONT PANEL 2PCS Carton No: 1</p>	<p>DRAWER LEFT PANEL 2PCS Carton No: 1</p>

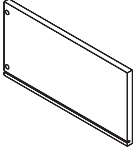
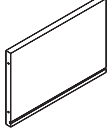
AXEL BEDSIDE TABLE-OAK ASSEMBLY INSTRUCTIONS

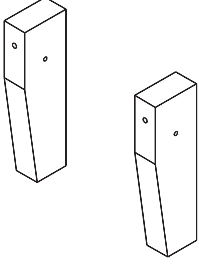
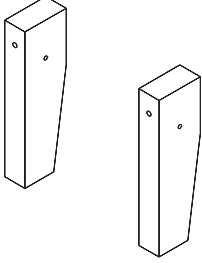
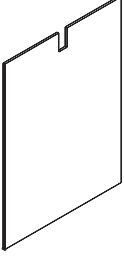
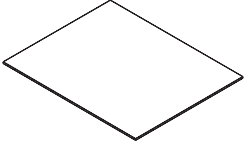
<p>P10</p> 	<p>P11</p> 	<p>P12</p> 
<p>DRAWER RIGHT PANEL 2PCS Carton No: 1</p>	<p>DRAWER BACK PANEL 2PCS Carton No: 1</p>	<p>HANDLE 2PCS Carton No: 1</p>
<p>P13</p> 	<p>P14</p> 	<p>P15</p> 
<p>LEG (LEFT) 2PCS Carton No: 1</p>	<p>LEG (RIGHT) 2PCS Carton No: 1</p>	<p>BACK PANEL 1PC Carton No: 1</p>
<p>P16</p> 		
<p>DRAWER BOTTOM PANEL 2PCS Carton No: 1</p>		

MADRID OTTOMAN BED 150CM ASSEMBLY INSTRUCTIONS

Fixings (to scale)

Ref	Dimensions	Qty
H1	DOWEL M6 X 30MM	16
H2	SCREW M4 X 35MM	12
H3	SCREW M3 X 12MM	28
H4	SCREW M3 X 16MM	4
H5	SCREW M7 X 70MM	4
H6	SCREW M4 X 20MM	4
H14	SCREW M4 X 50MM	8

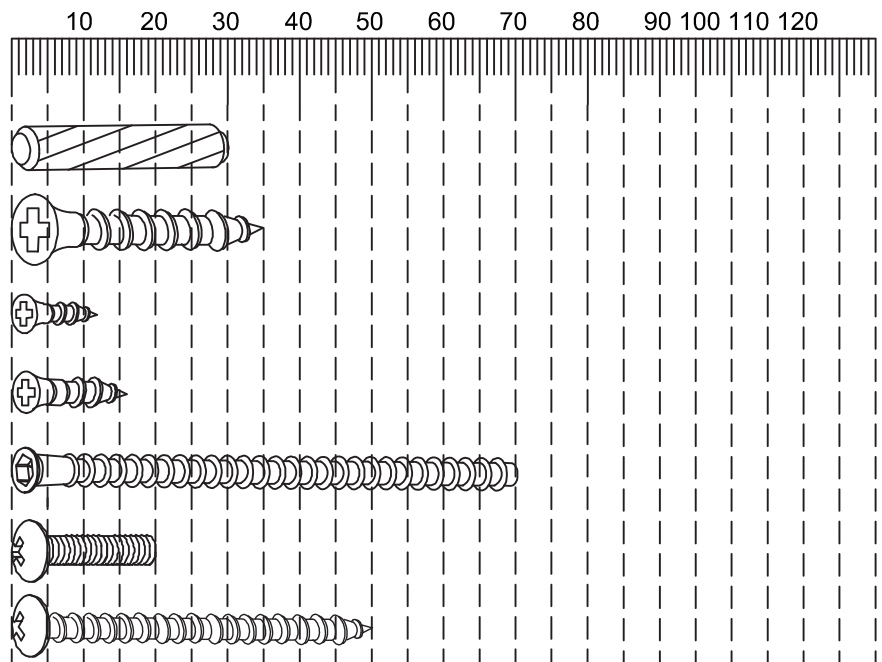

(Not to scale)

Ref	Dimensions	Qty
H7	CAM BOLT	16
H8	CAM LOCKER	16
H9	TIP OVER BRACKET	1
H10	ALLEN KEY	1
H11	FELT PAD	4
H12	STICKER	16



Ref	Dimensions	Qty
H13	CR	2
H13	CL	2
H13	DL	2
H13	DR	2
H15	BRACKETS	4
H17	CORNER BRACKET	4

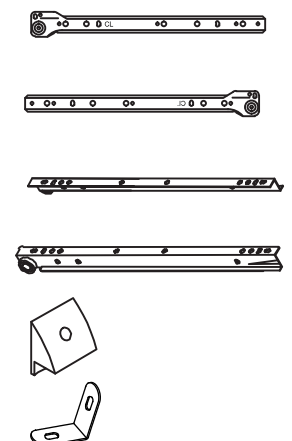

CAUTION: There are many small components used in the construction of this product. Please keep these components away from young children whilst assembling this product.

If you keep the fittings in a bowl during assembly you will be less likely to lose them

AXEL BEDSIDE TABLE-OAK ASSEMBLY INSTRUCTIONS

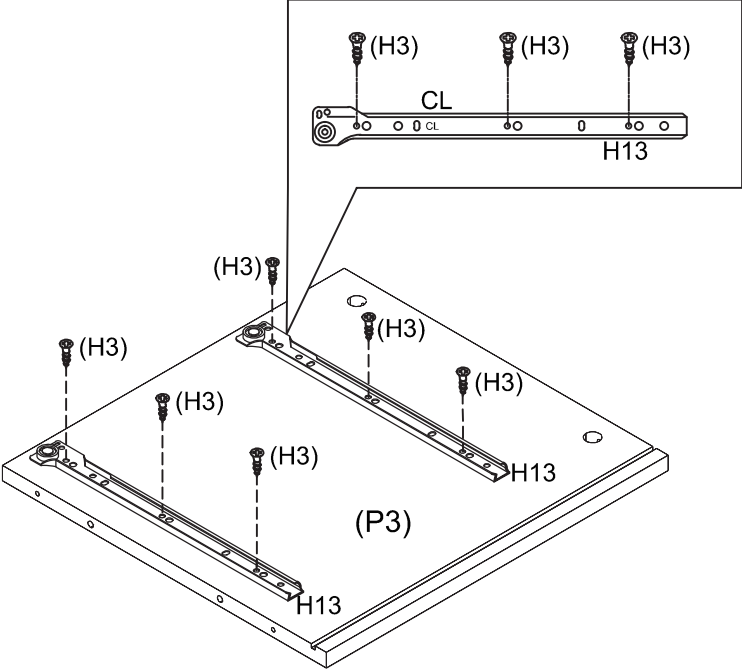
STEP 1 (Right Side Rail)	Parts Required
	<p>(P3) Left Side Panel - 1pc</p> <p>(H3) JCBC Screw M3x12mm - 6pcs</p> <p>(H13) CL-2PCS</p>

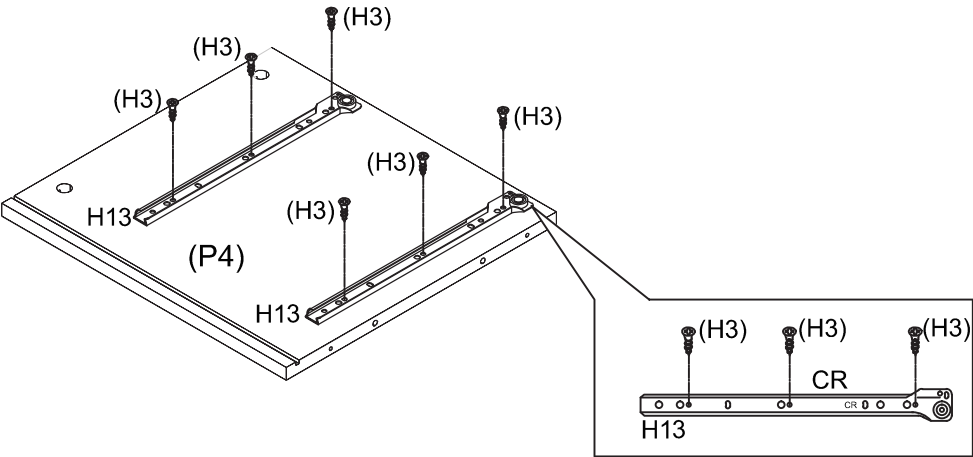
STEP 2 (Left Side Rail)	Parts Required
	<p>(P4) Right Side Panel - 1pc</p> <p>(H3) JCBC Screw M3x12mm - 6pcs</p> <p>(H13) CR-2PCS</p>

AXEL BEDSIDE TABLE-OAK ASSEMBLY INSTRUCTIONS

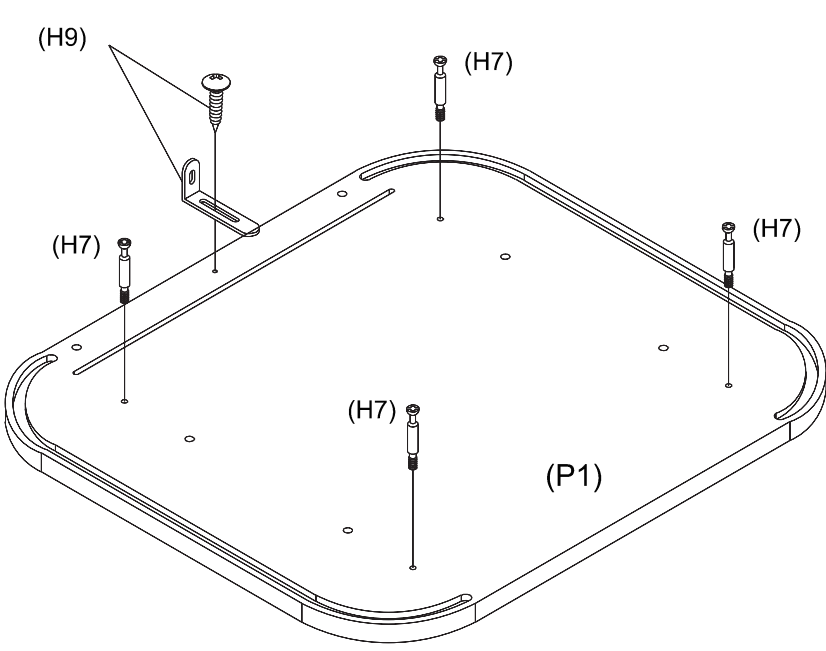
STEP 3 (Right Side Rail)	Parts Required
	<p>(P1) Top Panel-1PCS</p> <p>(H7) Cam Bolt-4PCS</p> <p>(H9) Tip Over Barcket-1PCS</p>

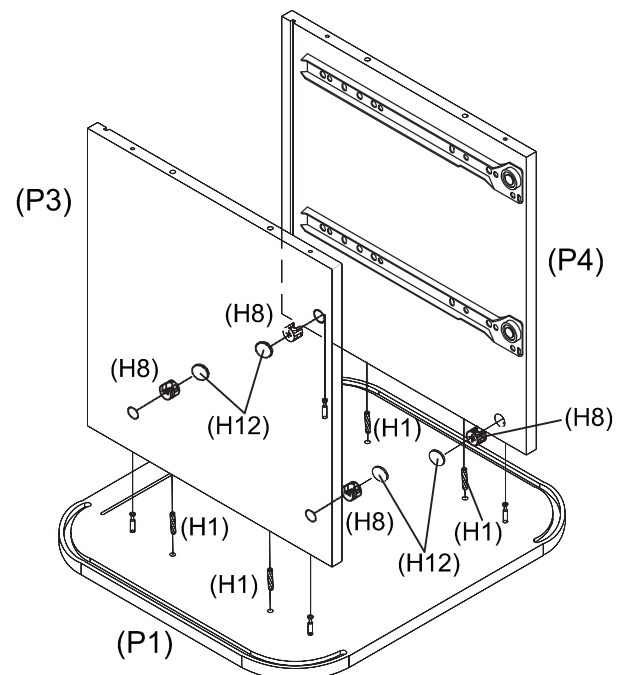
STEP 4 (Left Side Rail)	Parts Required
	<p>(P1) Top Panel -1pc</p> <p>(P3) Left Side Panel - 1pc</p> <p>(P4) Right Side Panel - 1pc</p> <p>(H1) Dowel M6 X 30mm - 4pcs</p> <p>(H8) Cam Locker -4PCS</p> <p>(H12) Sticker-4PCS</p>

AXEL BEDSIDE TABLE-OAK ASSEMBLY INSTRUCTIONS

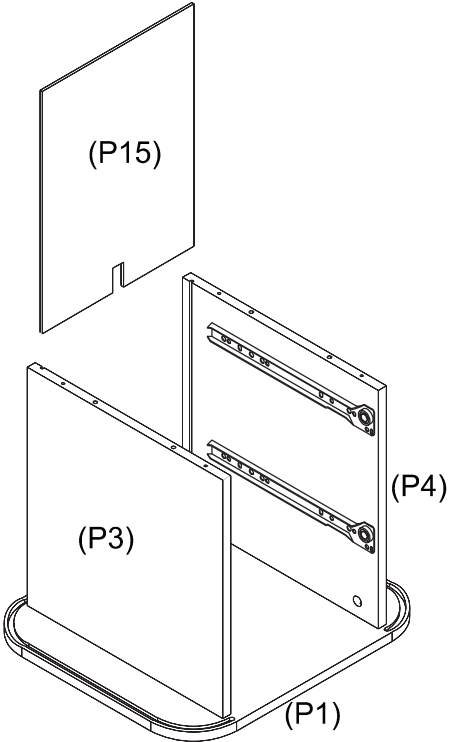
STEP 5 (Right Side Rail)	Parts Required
	(P15) Back Panel -1pc

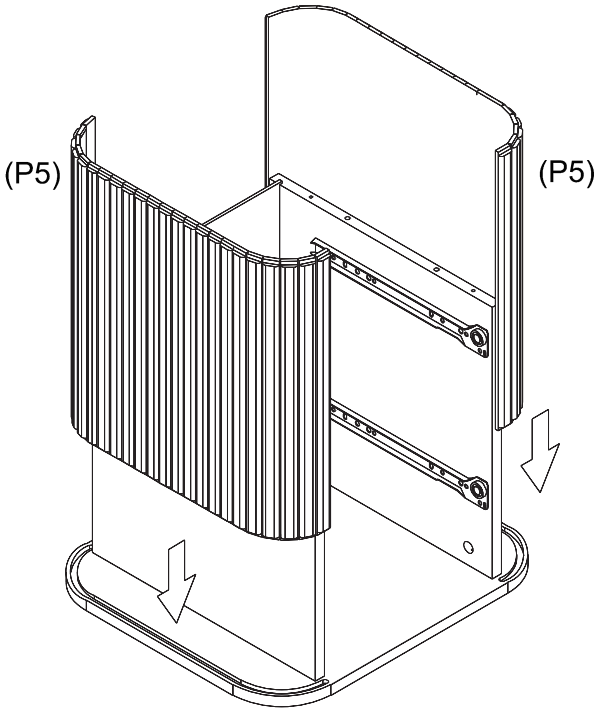
STEP 6 (Left Side Rail)	Parts Required
	(P5) Fluted Rails - 2pcs

AXEL BEDSIDE TABLE-OAK ASSEMBLY INSTRUCTIONS

STEP 7	Parts Required
<p>The diagram illustrates the assembly of the top panel (P2) onto the side panels (H1). Four screws (H2) are used to secure the top panel to the side panels. Four dowels (H1) are used to align the top panel with the side panels. The side panels are shown with a vertical slat design. The top panel has four pre-drilled holes for the screws and four corresponding holes for the dowels. The side panels have corresponding holes for the dowels and a track for the top panel to slide into.</p>	<p>(P2) Bottom Panel - 1pc</p> <p>(H1) Dowel M6x30mm - 4pcs</p> <p>(H2) JCBC Screw M4X35mm-4pcs</p>

AXEL BEDSIDE TABLE-OAK ASSEMBLY INSTRUCTIONS

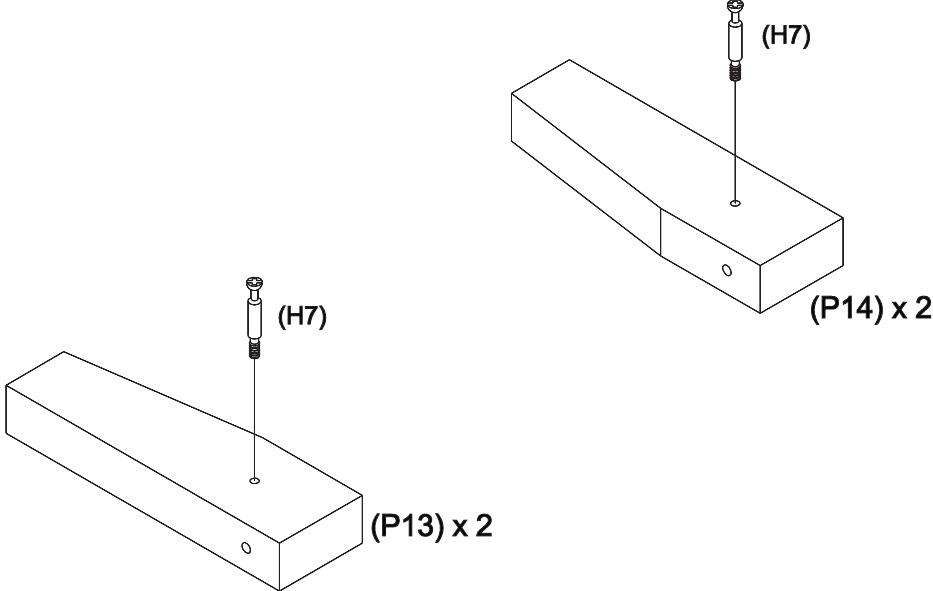
STEP 8	Parts Required
	<p>(P13) Leg (Left) - 2pcs</p> <p>(P14) Leg(Right) - 2pcs</p> <p>(H7) Cam Bolt-4PCS</p>

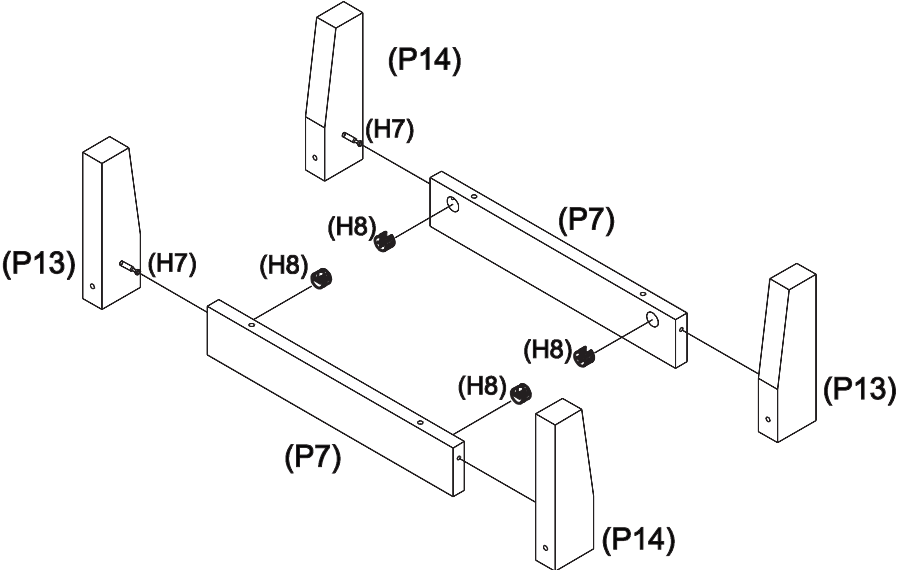
STEP 9	Parts Required
	<p>(P7) Bottom Left/Right Rails - 2pcs</p> <p>(H8) Cam Locker-4PCS</p>

AXEL BEDSIDE TABLE-OAK ASSEMBLY INSTRUCTIONS

STEP 10	Parts Required
	<p>(P6) Bottom Front/Back Rails - 2 pcs</p> <p>(H5) JCBC Screw M7x70mm - 4pcs</p> <p>(H10) Hex Key - 1pc</p> <p>(H11) Felt Pad-4PCS</p> <p>(H12) Sticker-4PCS</p>

STEP 11	
	<p>(H1) Dowel M6x30mm M6x30mm - 8pcs</p> <p>(H14) JCBC Screw M4X50mm - 8pcs</p>

AXEL BEDSIDE TABLE-OAK ASSEMBLY INSTRUCTIONS

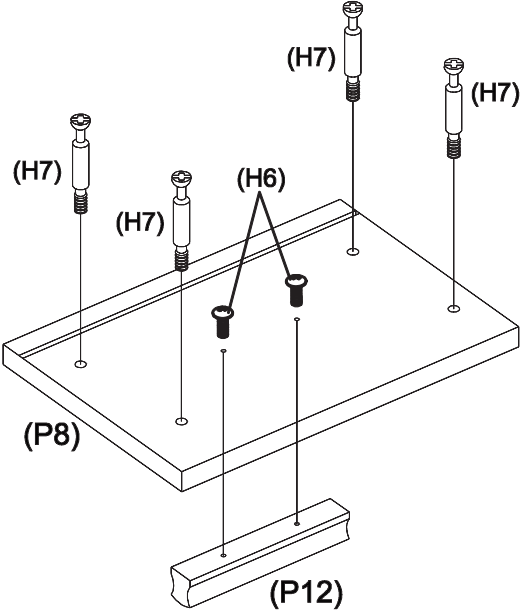
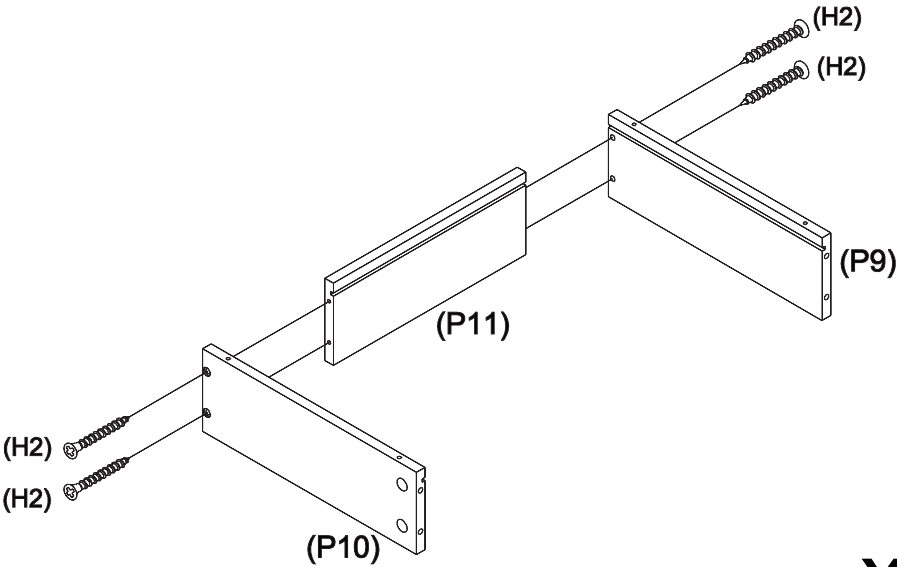
STEP 12	Parts Required
 <p style="text-align: right; font-size: 2em; font-weight: bold;">x2</p>	<p>(P8) Drawer Front Panel -2pcs</p> <p>(P12) Handle - 2pcs</p> <p>(H6) Screw-4pcs</p> <p>(H7) Cam Bolt-8pcs</p>
STEP 13	Parts Required
 <p style="text-align: right; font-size: 2em; font-weight: bold;">x2</p>	<p>(P9) Drawer Left Panel - 2pcs</p> <p>(P10) Drawer Right Panel - 2pcs</p> <p>(P11) Drawer Back Panel - 2pcs</p> <p>(H2) JCBC Screw M5X35mm- 8pcs</p>

AXEL BEDSIDE TABLE-OAK ASSEMBLY INSTRUCTIONS

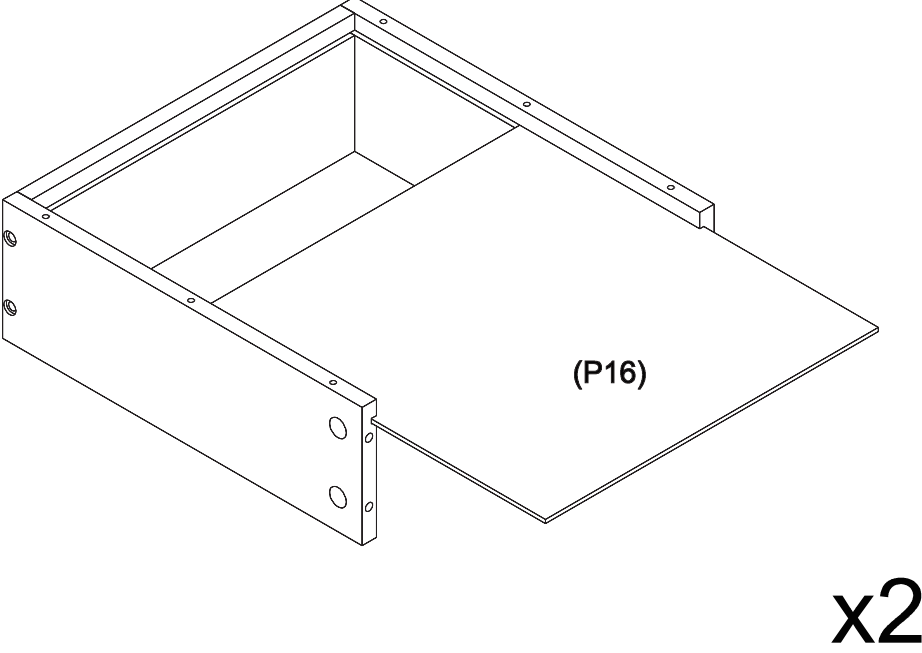
STEP 14	Parts Required
	<p>(P16) Drawer Bottom Panel - 2pcs</p>

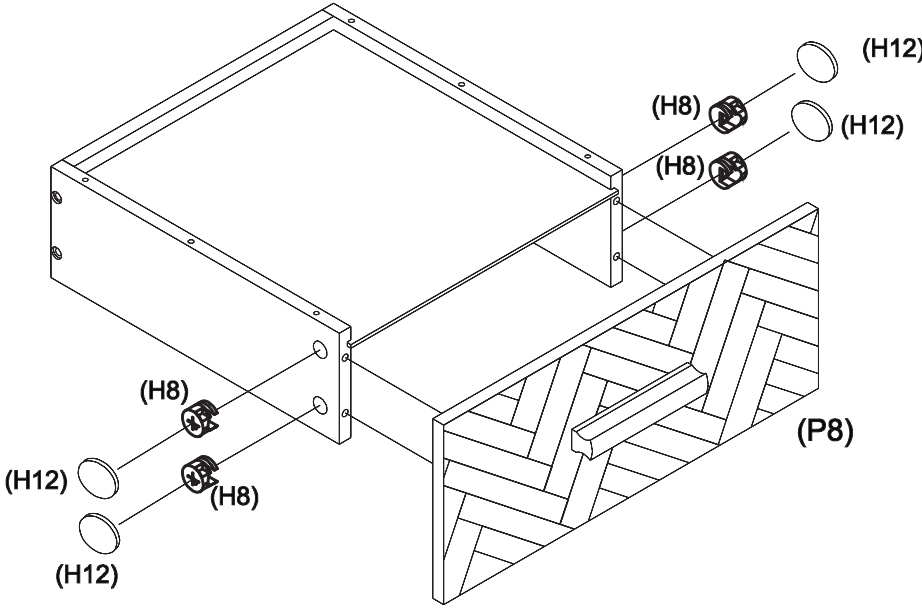
STEP 15	Parts Required
	<p>(H8) Cam Locker-8pcs</p> <p>(H12) Sticker-8pcs</p>

AXEL BEDSIDE TABLE-OAK ASSEMBLY INSTRUCTIONS

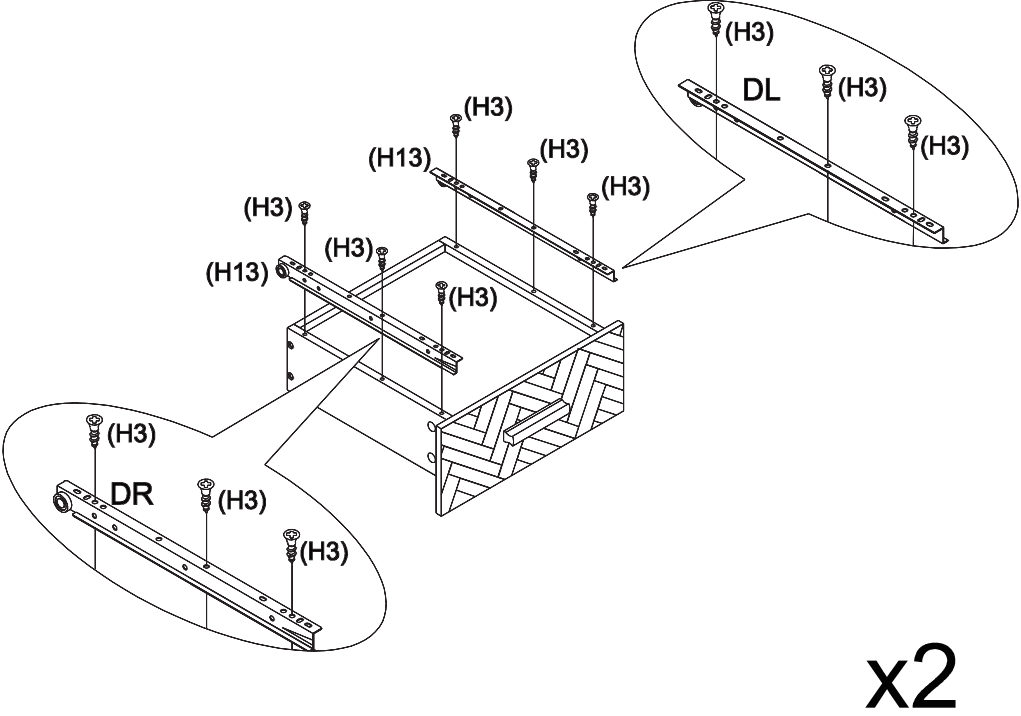
STEP 16	Parts Required
 <p style="text-align: right; font-size: 2em; font-weight: bold;">x2</p>	<p>(H3) JCBC Screw M3x12mm - 12pcs</p> <p>(H13) DL-2pcs</p> <p>(H13) DR-2pcs</p>

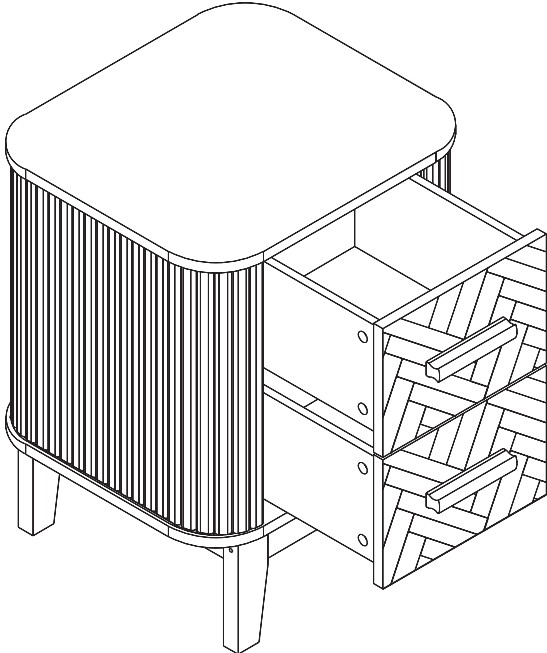
STEP 17	Parts Required
	

AXEL BEDSIDE TABLE-OAK ASSEMBLY INSTRUCTIONS

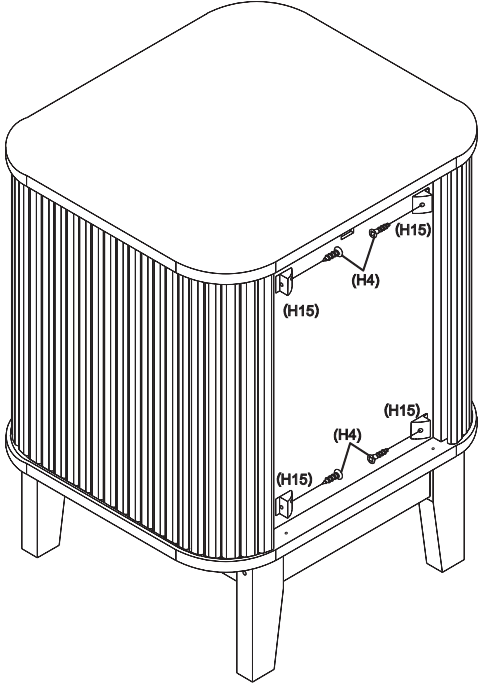
STEP 18	Parts Required
	<p>(H4) JCBC Screw M3x16mm - 4pcs</p> <p>(H15) Bracket-4pcs</p>

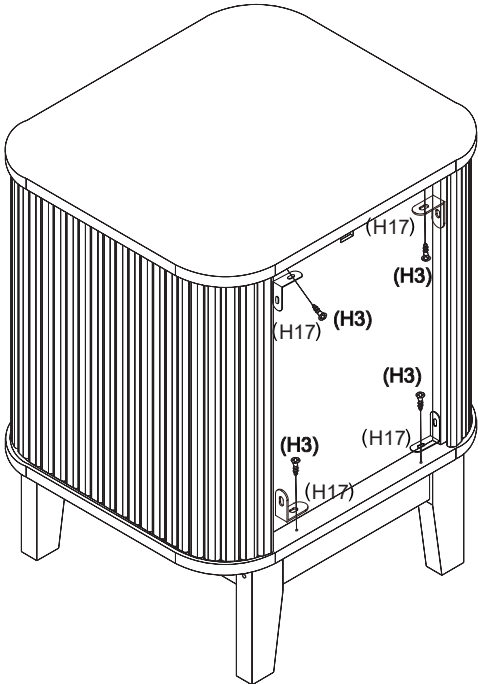
STEP 19	Parts Required
	<p>(H3) JCBC Screw M3x12mm -4pcs</p> <p>(H17) Corner Code -4pcs</p>

AXEL BEDSIDE TABLE-OAK ASSEMBLY INSTRUCTIONS

Complete Assembly

Your AXEL BEDSIDE TABLE is now completely assembled.
Periodically check to ensure that the components are in their proper position and free from damage.

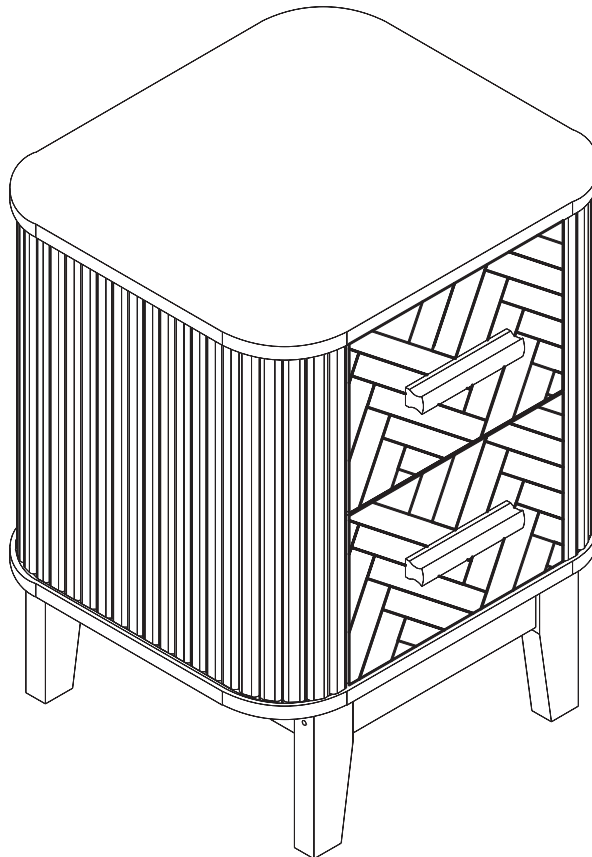

Keep instructions for future reference.

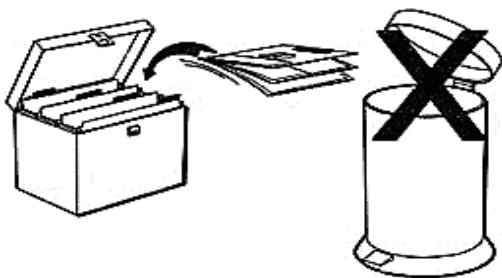

Supplied by : GFW THE FURNITURE
WAREHOUSE
Waterside Distribution Centre
Waterside Business Park
Johnson Road
Lancashire
BB3 3RT
www.gfwlimited.co.uk

Authorised Rep Compliance Ltd.
71 Lower Baggot Street
Dublin
D02 P593
Ireland
www.arccompliance.com