

ROWAN WIDE SHELVING UNIT ASSEMBLY INSTRUCTIONS

Thank you for purchasing the ROWAN WIDE SHELVING UNIT
Please read the instructions carefully to ensure safe operation of this product.

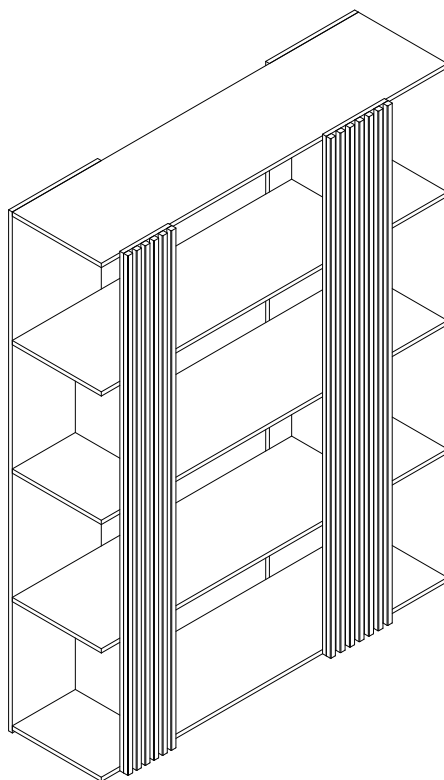

Size: 140x41x183cm

PLEASE READ this sheet prior to assembly to familiarise yourself with the various stages of construction.

Carefully open the pack supplied and check the contents against the parts and fittings check list. Do not destroy any of the packaging until you are certain that you have all the necessary parts for the assembly.

CAUTION: There are small components used in the construction of this unit. These loose items should be kept away from young children whilst assembling your unit to avoid the danger of choking.

Tools Required

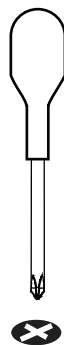
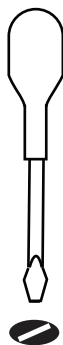

Number of people

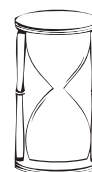

2 Hour
Set Up

ROWAN WIDE SHELVING UNIT ASSEMBLY INSTRUCTIONS

IMPORTANT - READ CAREFULLY - RETAIN THESE INSTRUCTIONS FOR FUTURE REFERENCE.

INFORMATION

- This product is designed to hold 30Kg spread evenly over the whole unit.
- Do not exceed this weight.
- We recommend that this unit is assembled in the room intended for use.
- When you are ready to start, make sure that you have the right tools, plenty of space and a clean, dry area for assembly.
- Unwrap all packaging materials and place the components on top of the carton box or on a clean floor to prevent any accidental scratching.
- Check the pack and make sure you have all the parts listed.
- Ensure that this product is fully assembled as illustrated before use.
- Check all screws or bolts are tightened and inspect regularly
- Tools not included unless specified in parts list.

WARNINGS

- This product should only be used on a firm and level floor.
- Keep small parts out of reach of children.
- Make sure the legs remain in contact with the floor.
- DO NOT use power tools to construct this product.
- DO NOT over-tighten screws or bolts.
- DO NOT use this product if parts are missing, damaged or worn.
- DO NOT sit or stand on the product.
- DO NOT place hot or Warm objects on the surface as these may damage the Product .
Always use a suitable heat resistant mat.

CARE INFORMATION

- Never use scourers, abrasives or chemical cleaners.
- To clean, wipe with a damp sponge and warm soapy water.
- Do not use solvent based cleaners or detergents as they can bleach or damage the product.

Parts and Fittings Checklist

Please check the pack contents before assembling the product. If any components are missing, please contact your retailer.

The fittings pack contains small items that should be kept away from children.

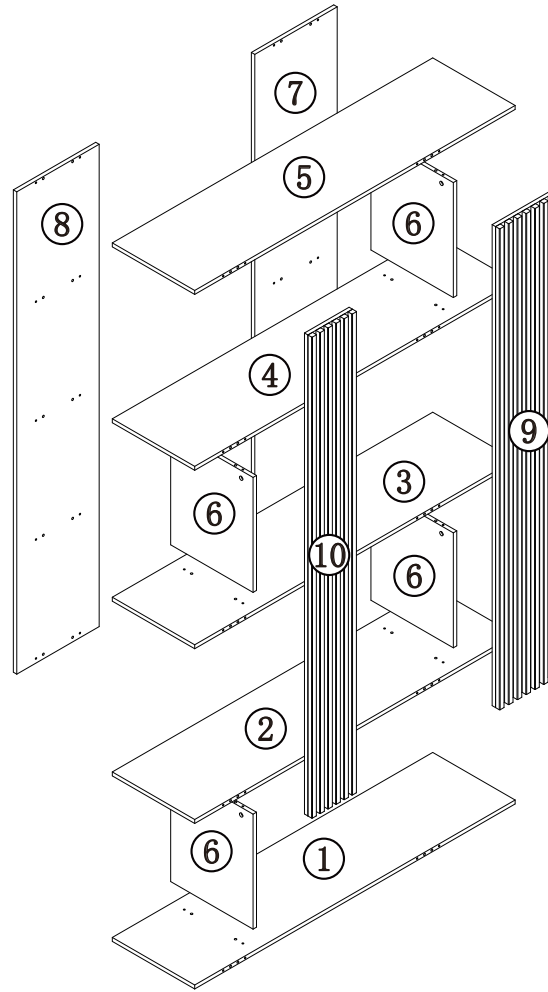

General Hints & Tips

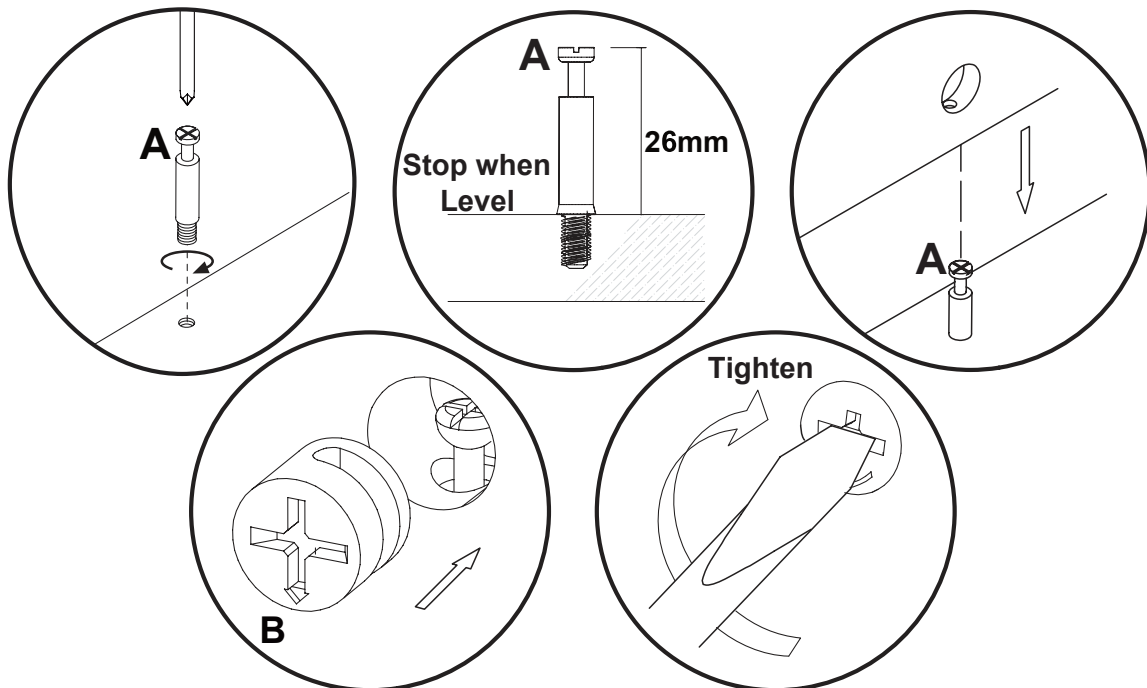

ROWAN WIDE SHELVING UNIT ASSEMBLY INSTRUCTIONS

All parts are packed in one carton

1	2	3
Description: BOTTOM PANEL Qty: 1 Size: 362x1400x15mm Carton No: 3/3	Description: SHELF Qty: 1 Size: 362x1400x15mm Carton No: 2/3	Description: SHELF Qty: 1 Size: 362x1400x15mm Carton No: 2/3
4	5	6
Description: SHELF Qty: 1 Size: 362x1400x15mm Carton No: 2/3	Description: TOP PANEL Qty: 1 Size: 362x1400x15mm Carton No: 2/3	Description: SUPPORT PANEL Qty: 4 Size: 361x438x15mm Carton No: 3/3
7	8	9
Description: BACK PANEL RIGHT Qty: 1 Size: 270x1830x15mm Carton No: 1/3	Description: BACK PANEL LEFT Qty: 1 Size: 270x1830x15mm Carton No: 1/3	Description: FRONT PANEL RIGHT Qty: 1 Size: 250x1830x33mm Carton No: 1/3
10		
Description: FRONT PANEL LEFT Qty: 1 Size: 195x1830x33mm Carton No: 1/3		

ROWAN WIDE SHELVING UNIT ASSEMBLY INSTRUCTIONS

Fittings (to scale)

Code	Item	Quantity
A	CAM BOLT (7x39mm)	28
B	CAM NUT	28
C	DOWEL (8x30mm)	56
D	SCREW (5x40mm)	28

Fittings (not to scale)

Code	Item	Quantity
E	FOOT	6
F	WALL FIXING	2

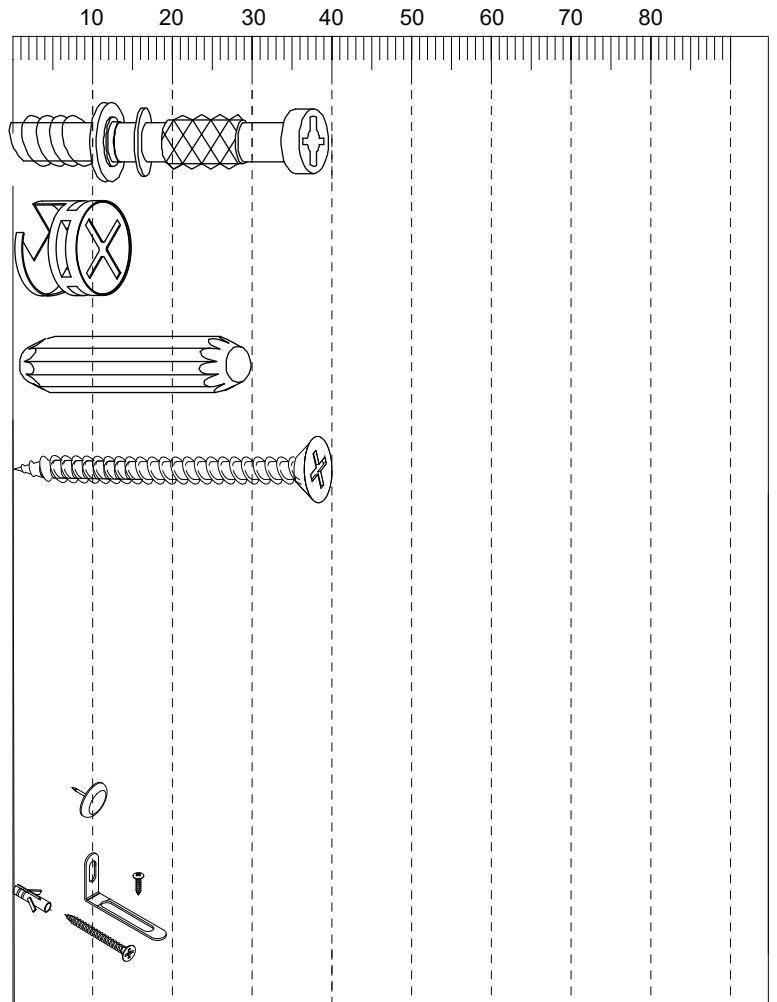

ROWAN WIDE SHELVING UNIT ASSEMBLY INSTRUCTIONS

STEP 1

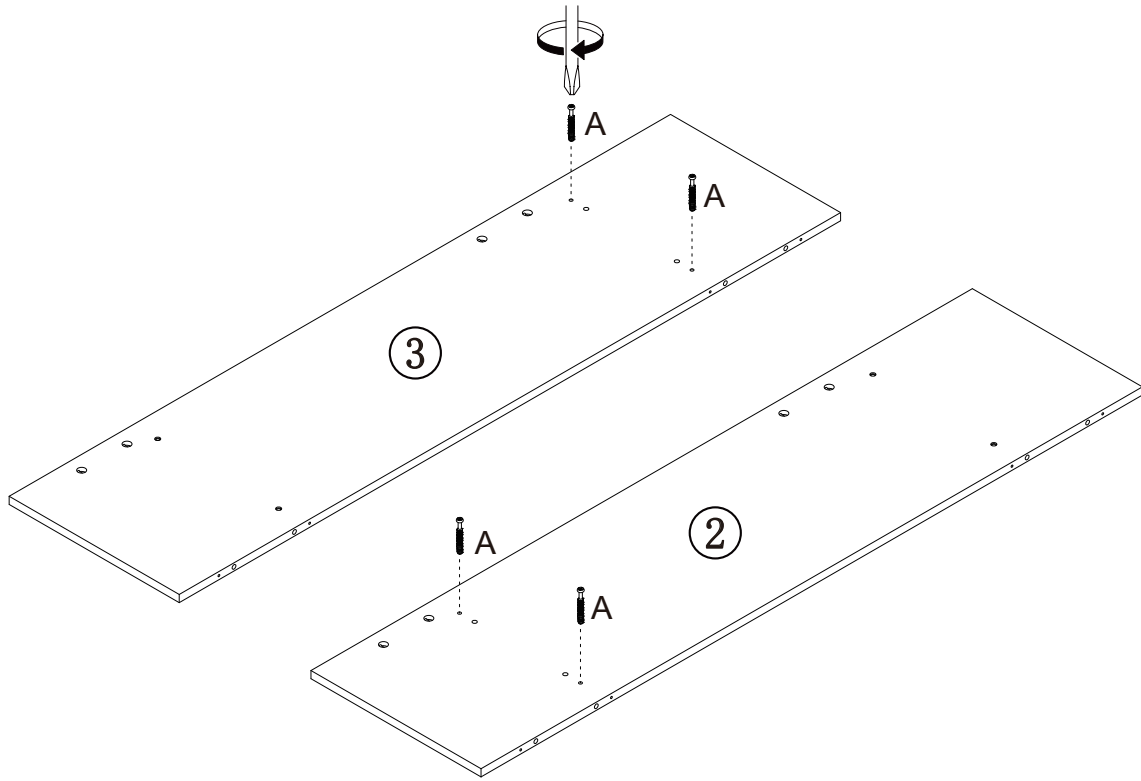

For this step:

Tools required

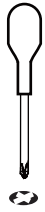

Fittings required



A x 4

STEP 2

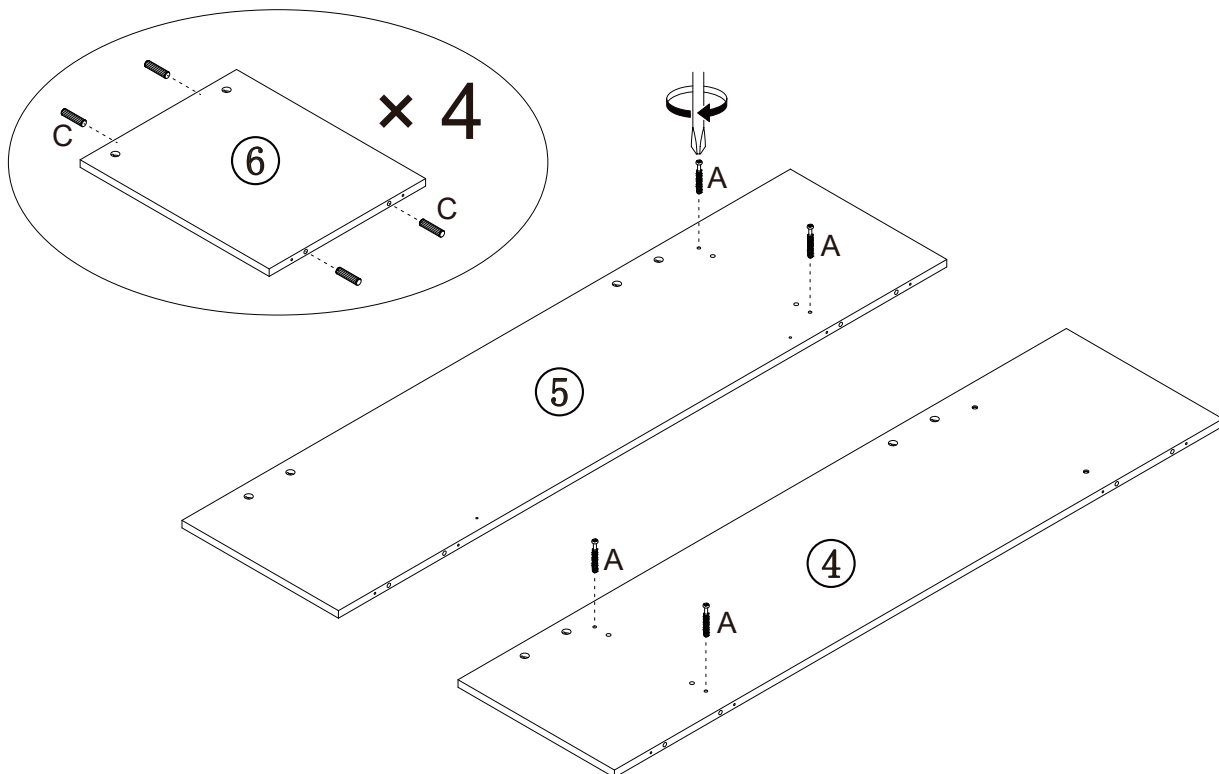

For this step:

Tools required

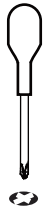

Fittings required



A x 4

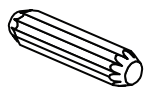

C x 16

ROWAN WIDE SHELVING UNIT ASSEMBLY INSTRUCTIONS

STEP 3

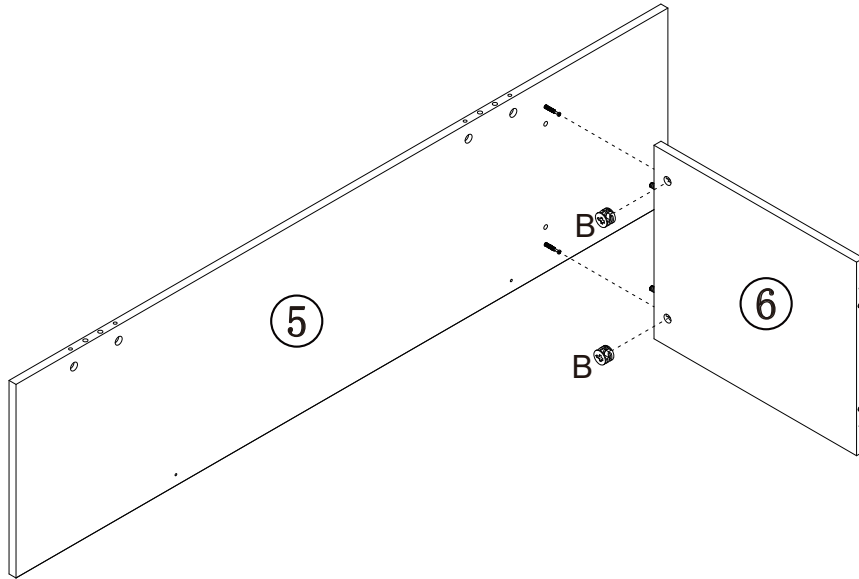

For this step:
Tools required

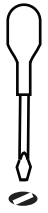

Fittings required



B x 2

STEP 4

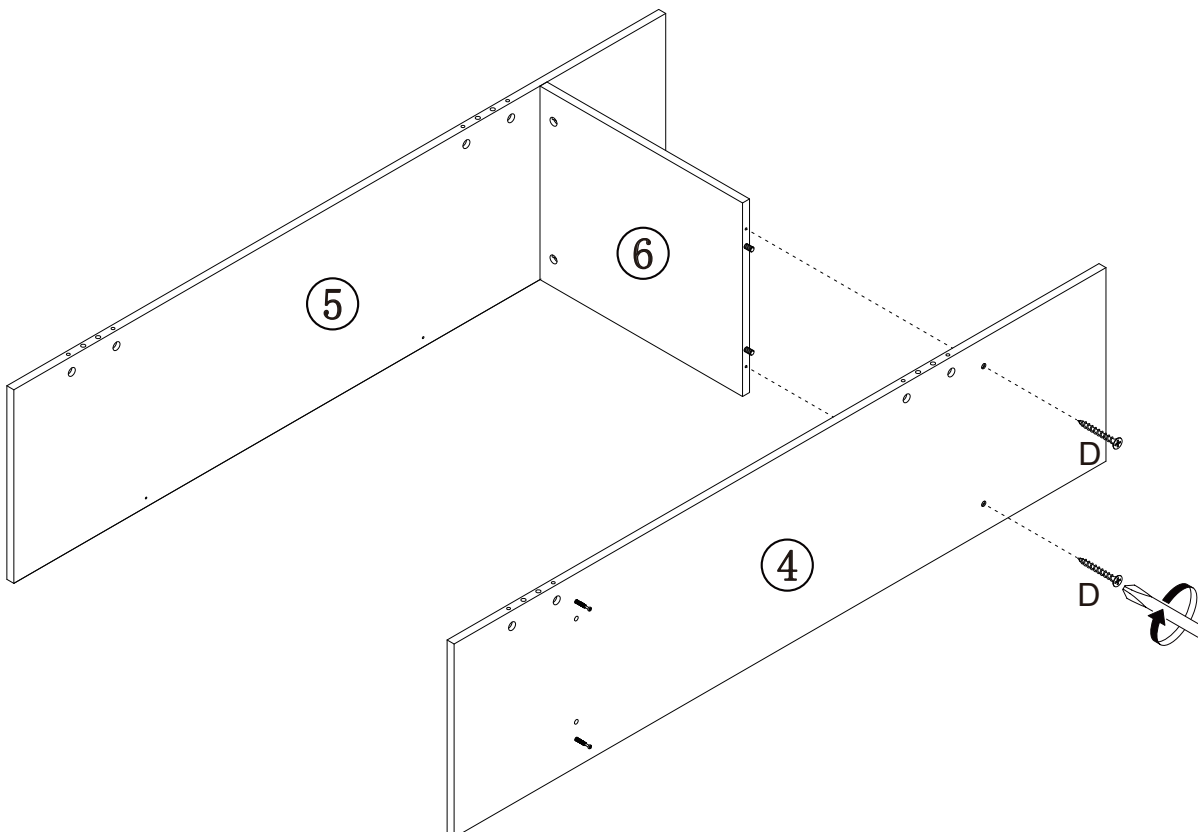

For this step:
Tools required

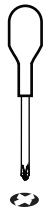

Fittings required

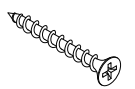

D x 2

ROWAN WIDE SHELVING UNIT ASSEMBLY INSTRUCTIONS

STEP 5

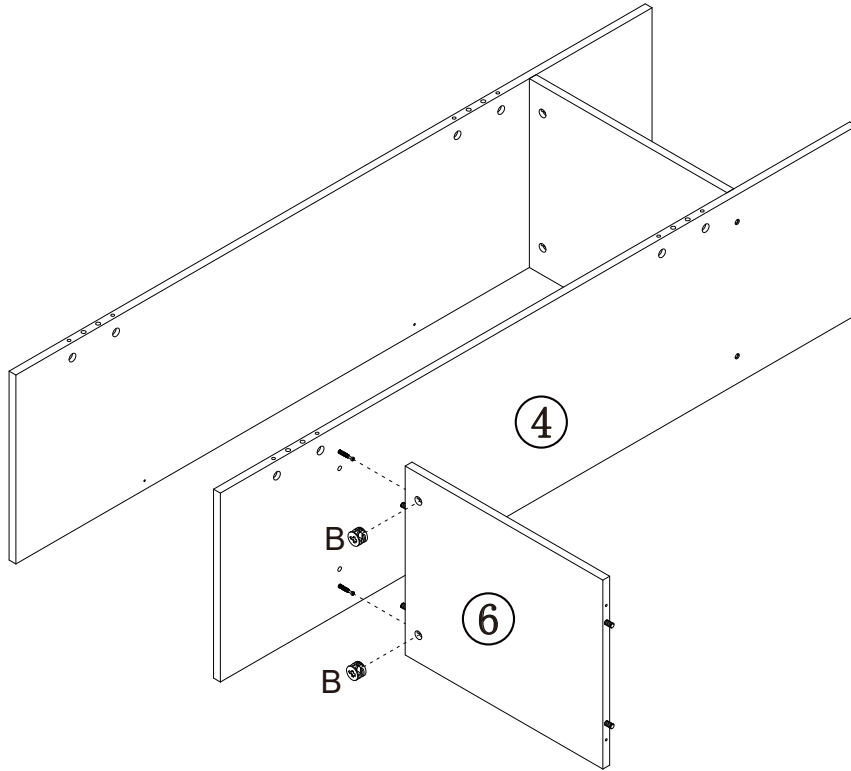

For this step:

Tools required



Fittings required



B x 2

STEP 6

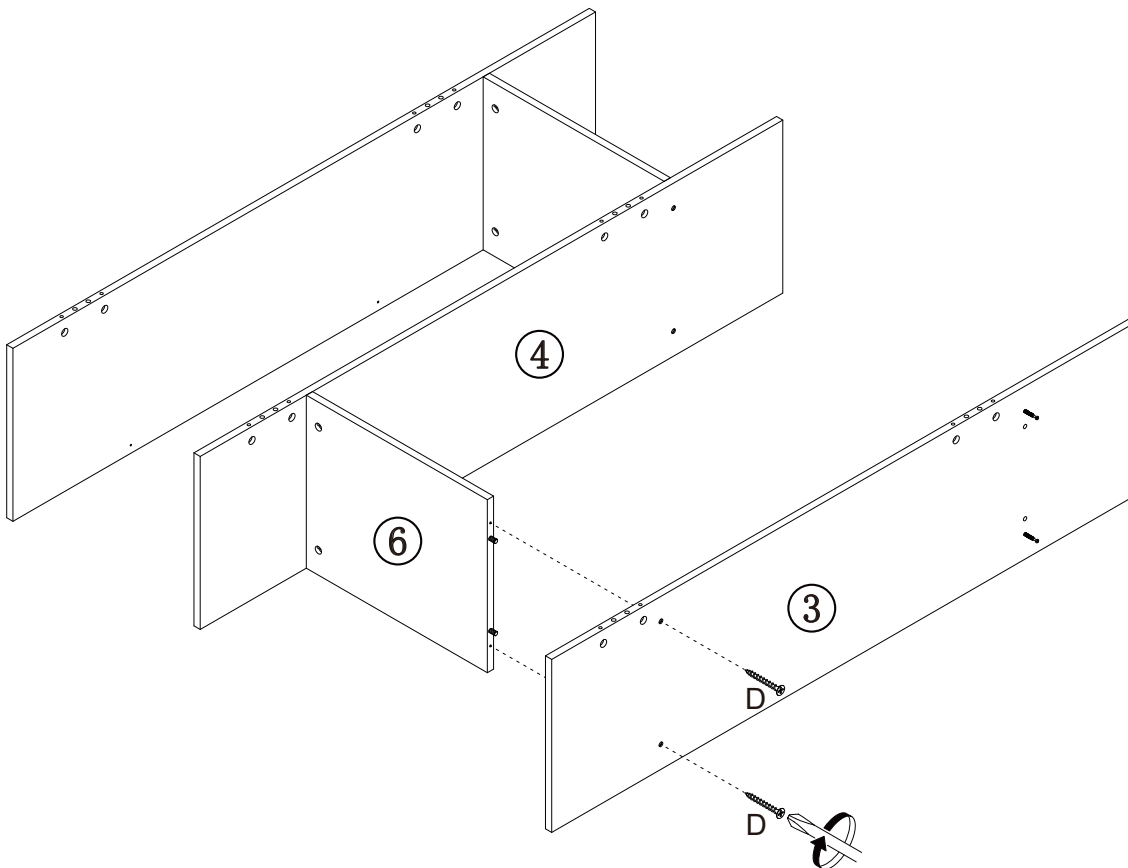

For this step:

Tools required

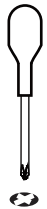

Fittings required

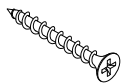

D x 2

ROWAN WIDE SHELVING UNIT ASSEMBLY INSTRUCTIONS

STEP 7

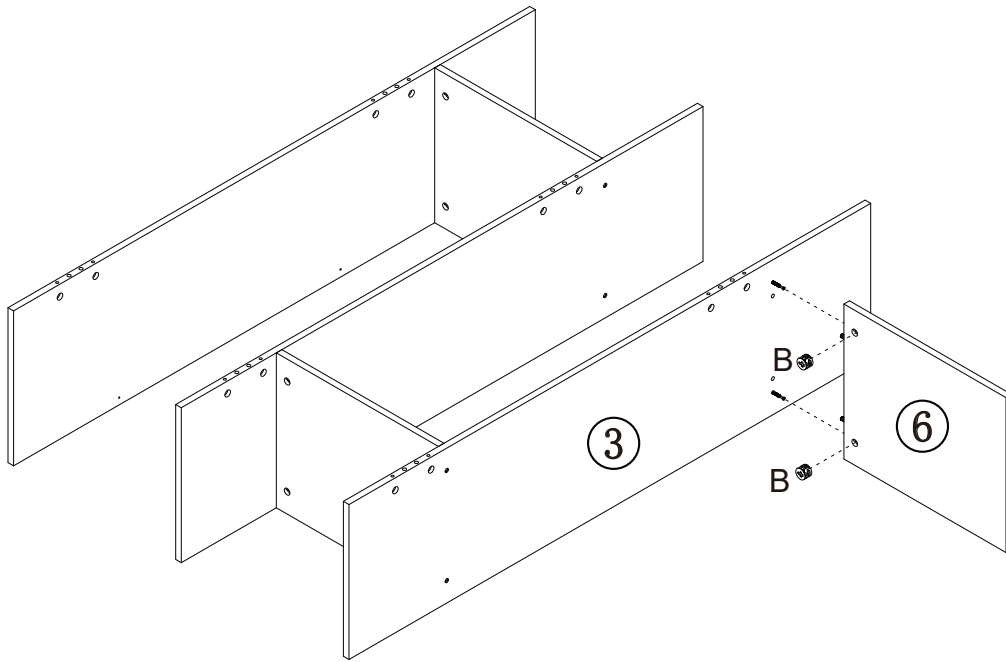

For this step:

Tools required

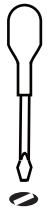

Fittings required



B x 2

STEP 8

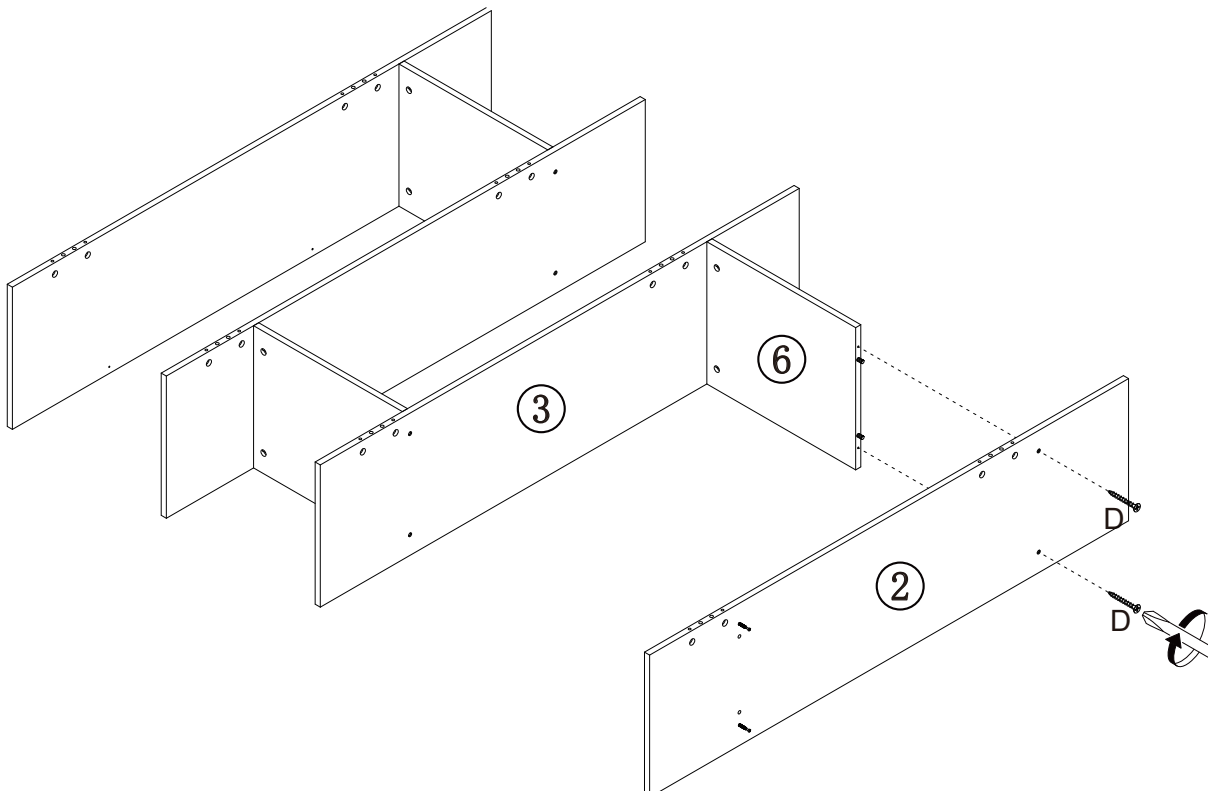

For this step:

Tools required

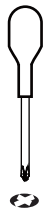

Fittings required

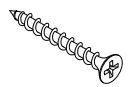

D x 2

ROWAN WIDE SHELVING UNIT ASSEMBLY INSTRUCTIONS

STEP 9

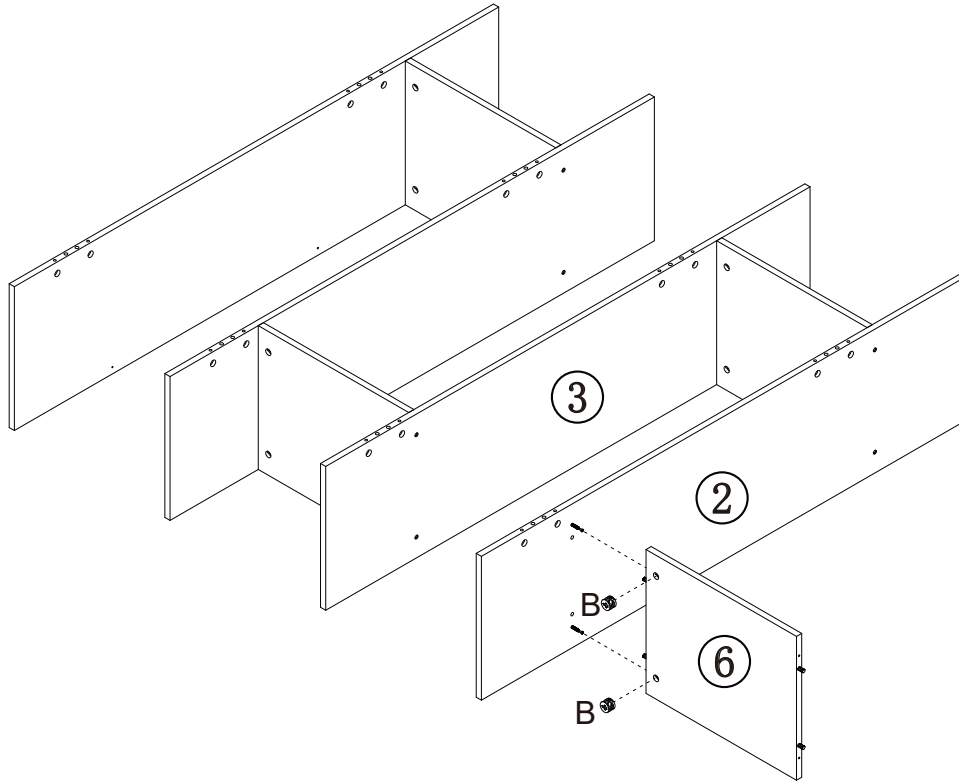

For this step:

Tools required

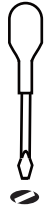

Fittings required



B x 2

STEP 10

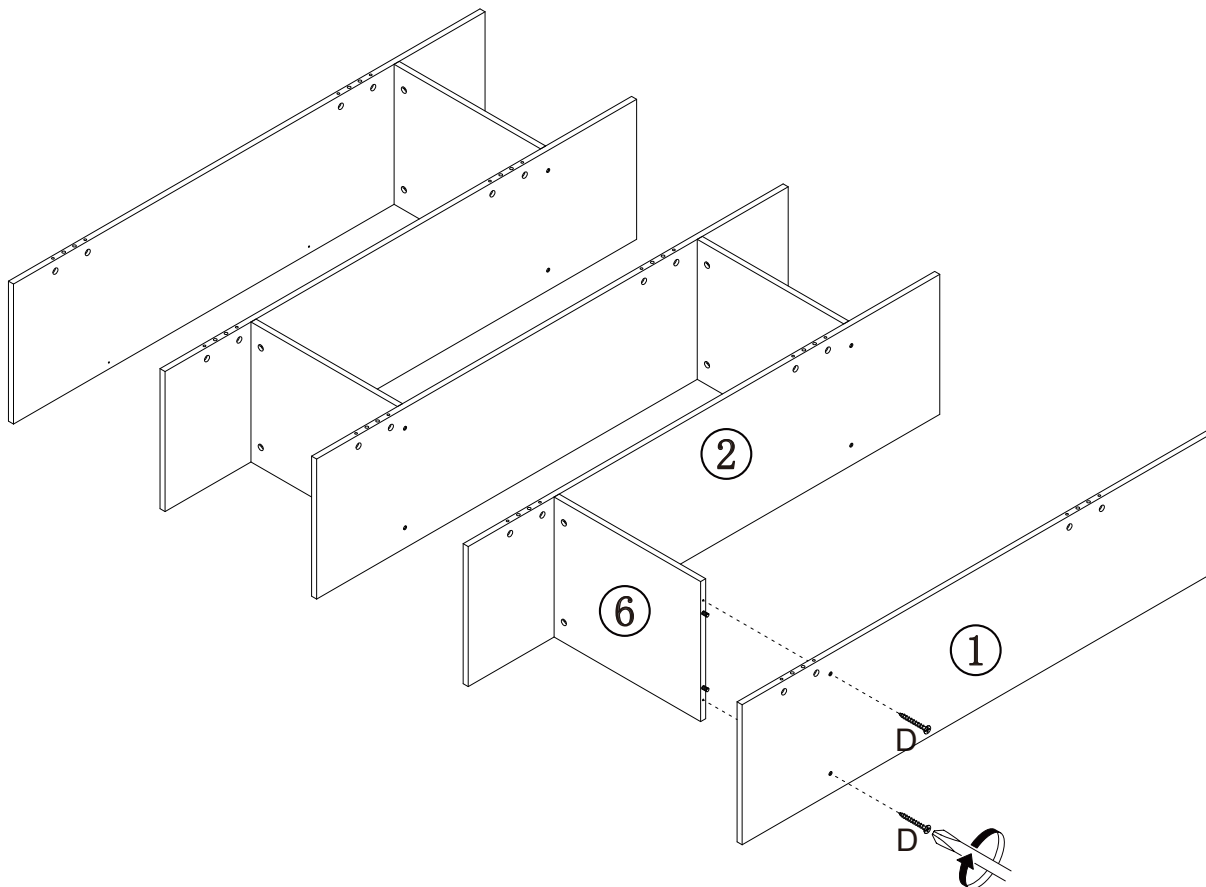

For this step:

Tools required

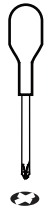

Fittings required

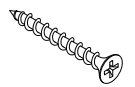

D x 2

ROWAN WIDE SHELVING UNIT ASSEMBLY INSTRUCTIONS

STEP 11

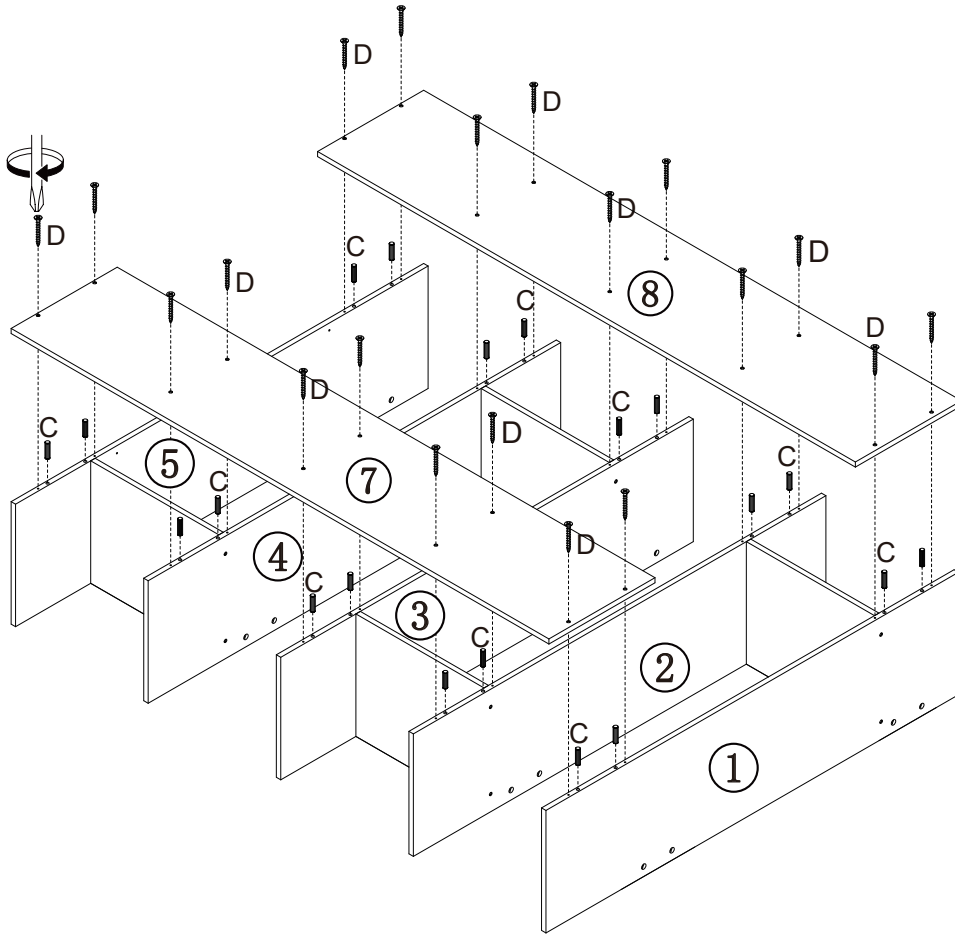

For this step:

Tools required

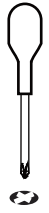

Fittings required

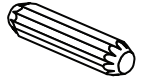

C x 20

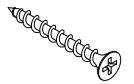

D x 20

STEP 12

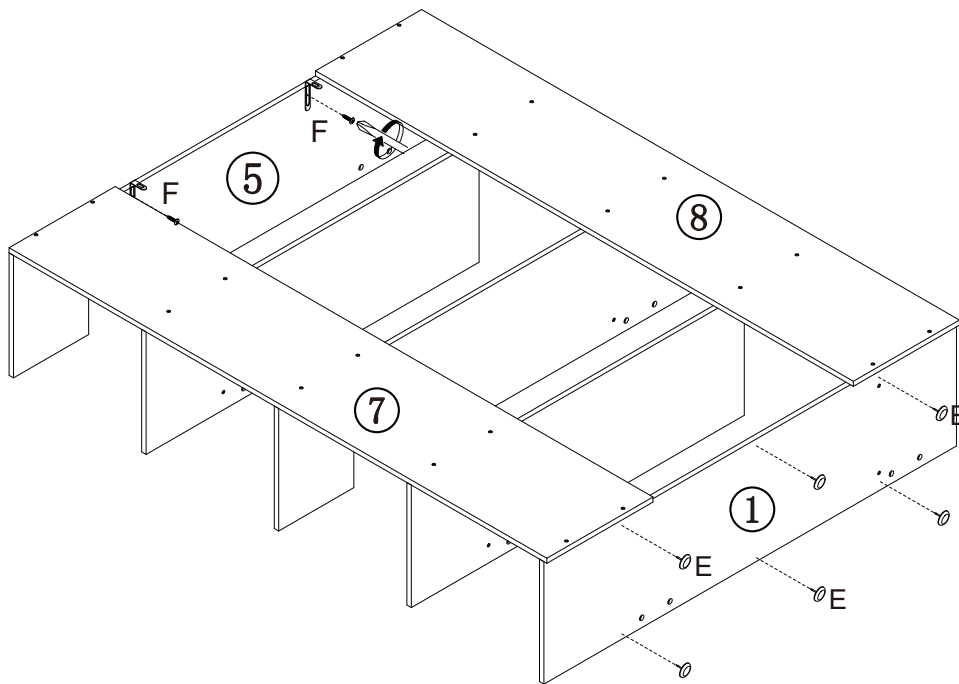

For this step:

Tools required



Fittings required



E x 6

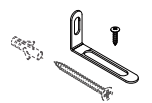

F x 2

ROWAN WIDE SHELVING UNIT ASSEMBLY INSTRUCTIONS

STEP 13

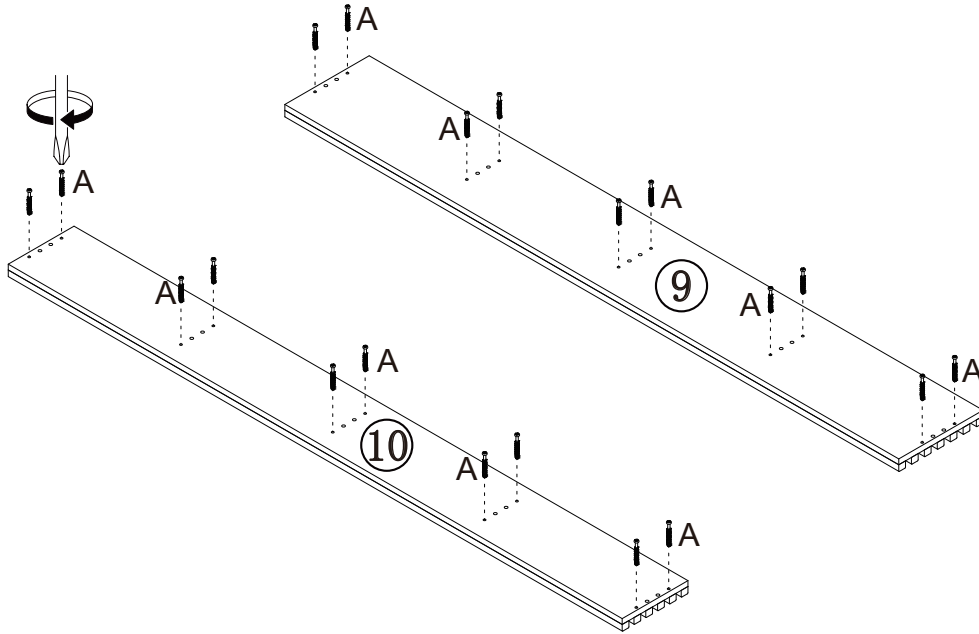

For this step:

Tools required

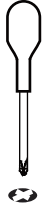

Fittings required



A x 20

STEP 14

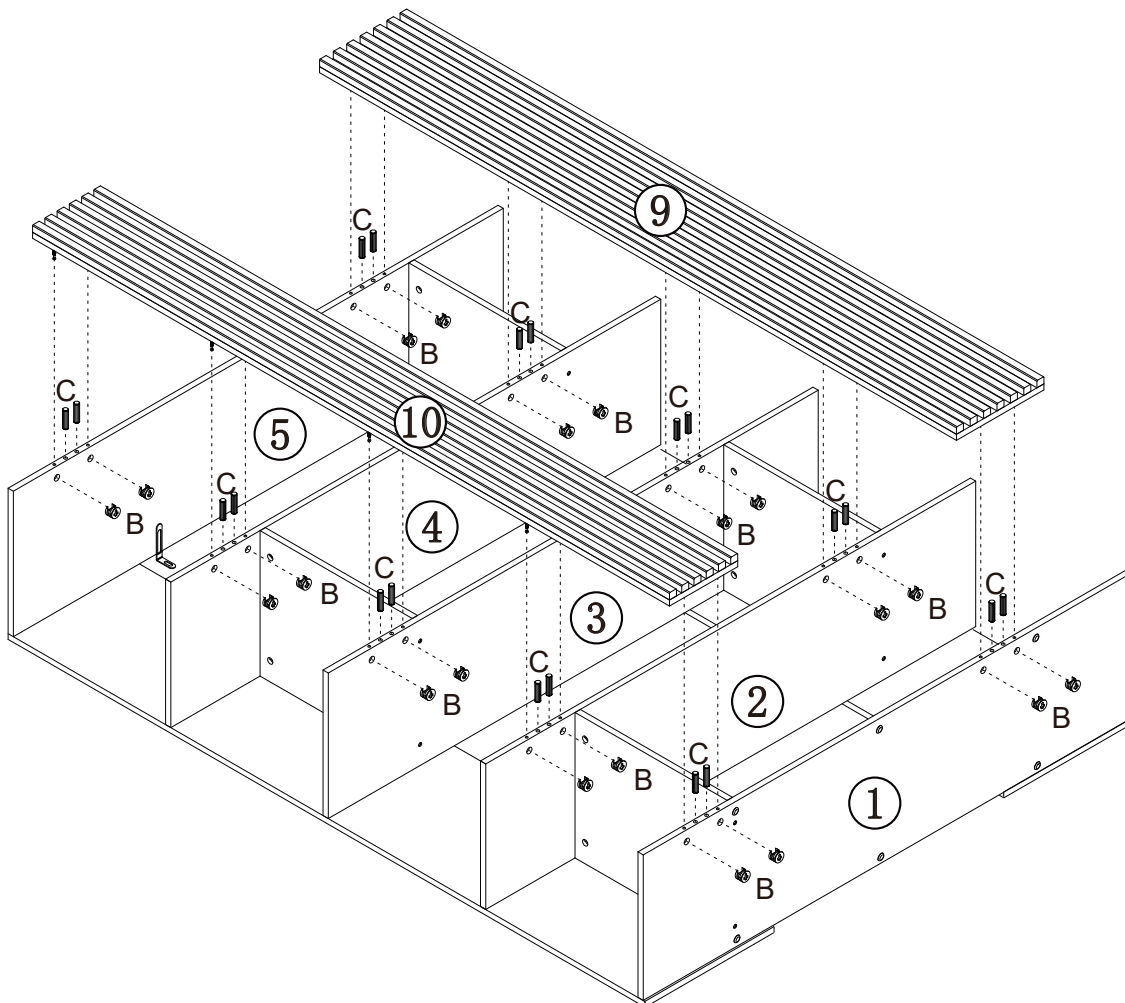

For this step:

Tools required



Fittings required



B x 20



C x 20

STEP 23

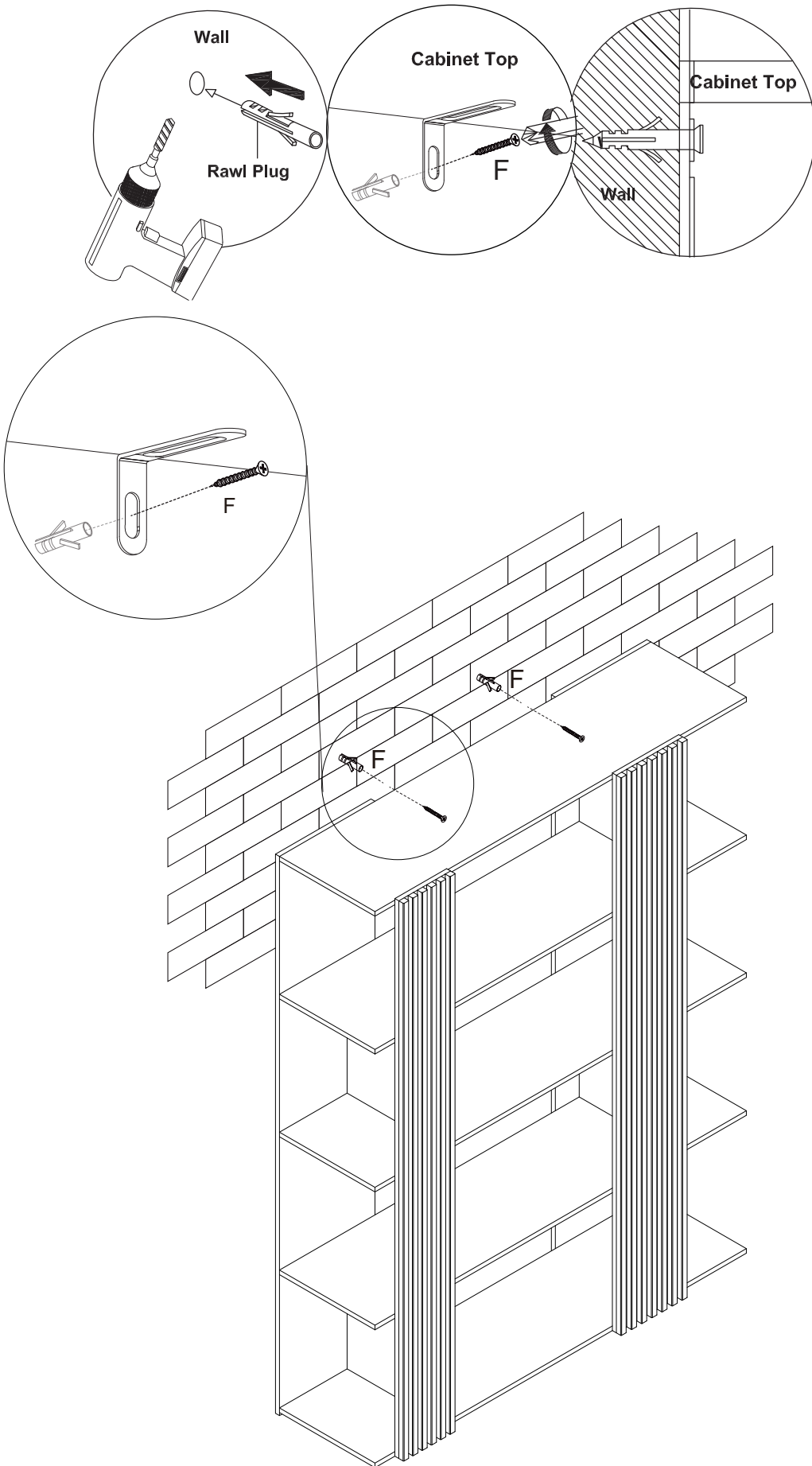

For this step:

Tools required

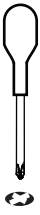

Fittings required

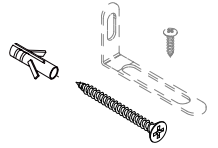

F x 2

Assembly Completed

Your ROWAN WIDE SHELVING UNIT is now completely assembled.

Periodically check to ensure that the components are in their proper position, free from damage.

Also, make sure the connectors are tight and secure.

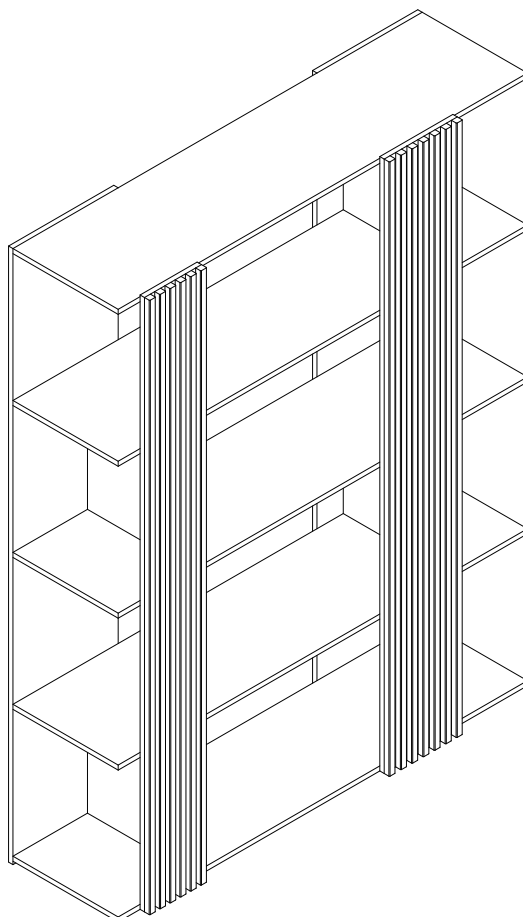

Keep instructions for future reference

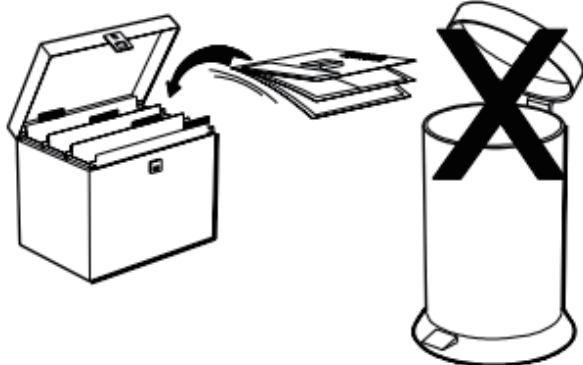

Represented by:
Authorised Rep Compliance Ltd
71 Lower Baggot Street
Dublin
D02 P593
Ireland
www.arccompliance.com

Supplied by:
GFW The Furniture Warehouse
Waterside Distribution Centre
Waterside Business Park
Johnson Road
Lancashire
BB3 3RT
www.gfwlimited.co.uk