

Tahlia

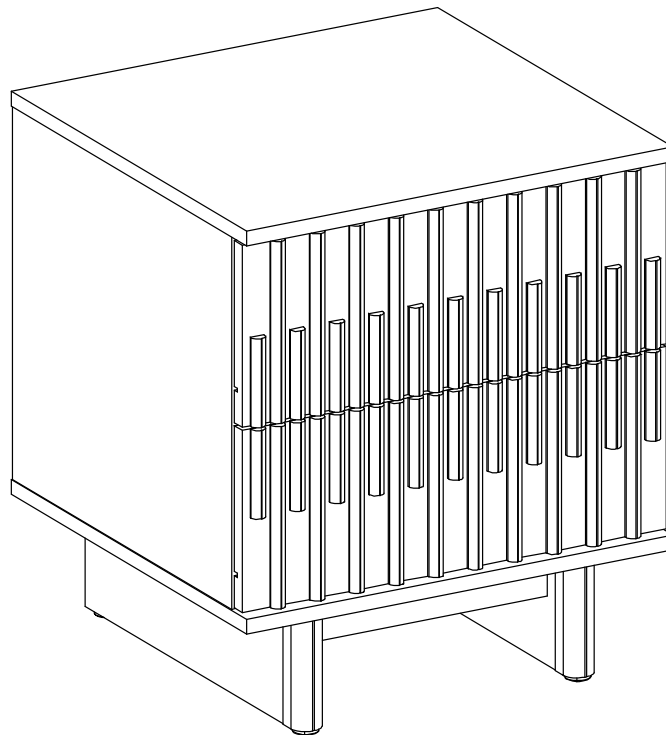

2 Drawer Bedside

Assembly & Care Instructions



Getting Started.





1. Check you have received all parts listed on the component and hardware pages and the correct quantity of each. Beware that sometimes parts are packaged within the product so not immediately visible after opening. Please check the assembly section for more details. If anything is missing, stop assembling the product and contact our customer service team.
2. Check all parts are intact and undamaged. Any issues, stop assembling the product and contact our customer service team.
3. Check you have the right tools for the job. Required tools which are not provided are listed below. If you are unsure of how to use these tools, please contact a professional tradesperson. We recommend Airtasker as an easy way to find trades people in your local area.

Tools required which are not included	
Cross head screwdriver	Hammer
	







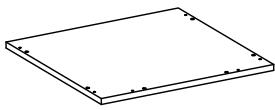
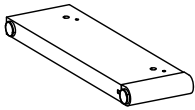
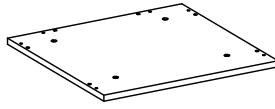

Safety advice.

Dear Customer

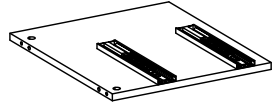
- **IMPORTANT** – The first step you need to take is to ensure your safety! Please take the time to read and understand these instructions before assembling the product.
- Please keep these instructions for future reference.
- This item is intended for indoor use only – unless otherwise specified. Avoid exposure to humid conditions.
- Assembly to be carried out by a competent adult only.
- During assembly children should be kept away from the product due to possible risk of injury. The product may contain small parts that could also cause choking if swallowed.
- Products can be dangerous if incorrectly installed or assembled. Assembly should be carried out by a competent person and instructions followed. No liability will be accepted for damage or injury caused by incorrectly installed or assembled products.
- Never use an electric drill to assemble a product, as this can cause damage to parts.
- Regularly check all fastenings to ensure that they are properly tightened.
- Restrain children from climbing or playing on or around the product. Always consider where products are positioned to ensure children cannot get access to long cords or windows.
- Some products will be supplied with anti – tip kits which should always be used to secure the product to the wall and prevent tipping.
- Keep all plastic wrapping materials away from babies and children to avoid danger of suffocation.
- Ensure that all packaging is disposed of carefully and responsibly. Please recycle where possible.
- Once items are part or fully assembled, they are not returnable unless faulty.

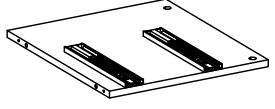
Max weight limit	No. of people to assemble	Assembly difficulty	Time to assemble
			
25 KG	2 recommended	Easy	<1 hours

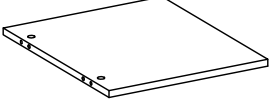
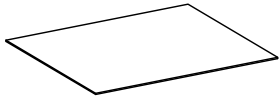
Parts supplied.

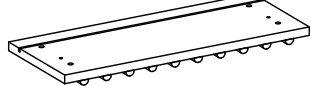
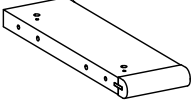
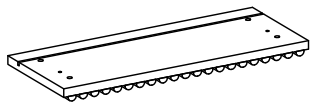
Ref	Part	Visual	Qty	Ref	Part	Visual	Qty
1	Top panel		1	8	Right leg		1
2	Bottom panel		1	9	Rear drawer		2
3	Left panel		1	10	Left drawer		2
4	Right panel		1	11	Right drawer		2
5	Rear panel		1	12	Bottom drawer		2
6	Bottom support		2	13	Top Front drawer		1
7	Left leg		1	14	Bottom Front drawer		1

Hardware supplied.

Ref	Hardware & dimension (mm)	Qty	mm	10	20	30	40	50	60	70	80	90	100
A	Camlock Dia.15 x 12mm	14											
B	Cambolt 7.5mm x 32mm	14											
C	Cover Dia.25mm	18											
D	Plastic dowel 8mm x 32mm	34											
E	Bolt 10mm x 33.5mm	10											
F	Barrel Nut Dia.10 x 13mm	4											
G	Bolt 6mm x 60mm	4											

Ref	Visual	Qty
H		4
I		1

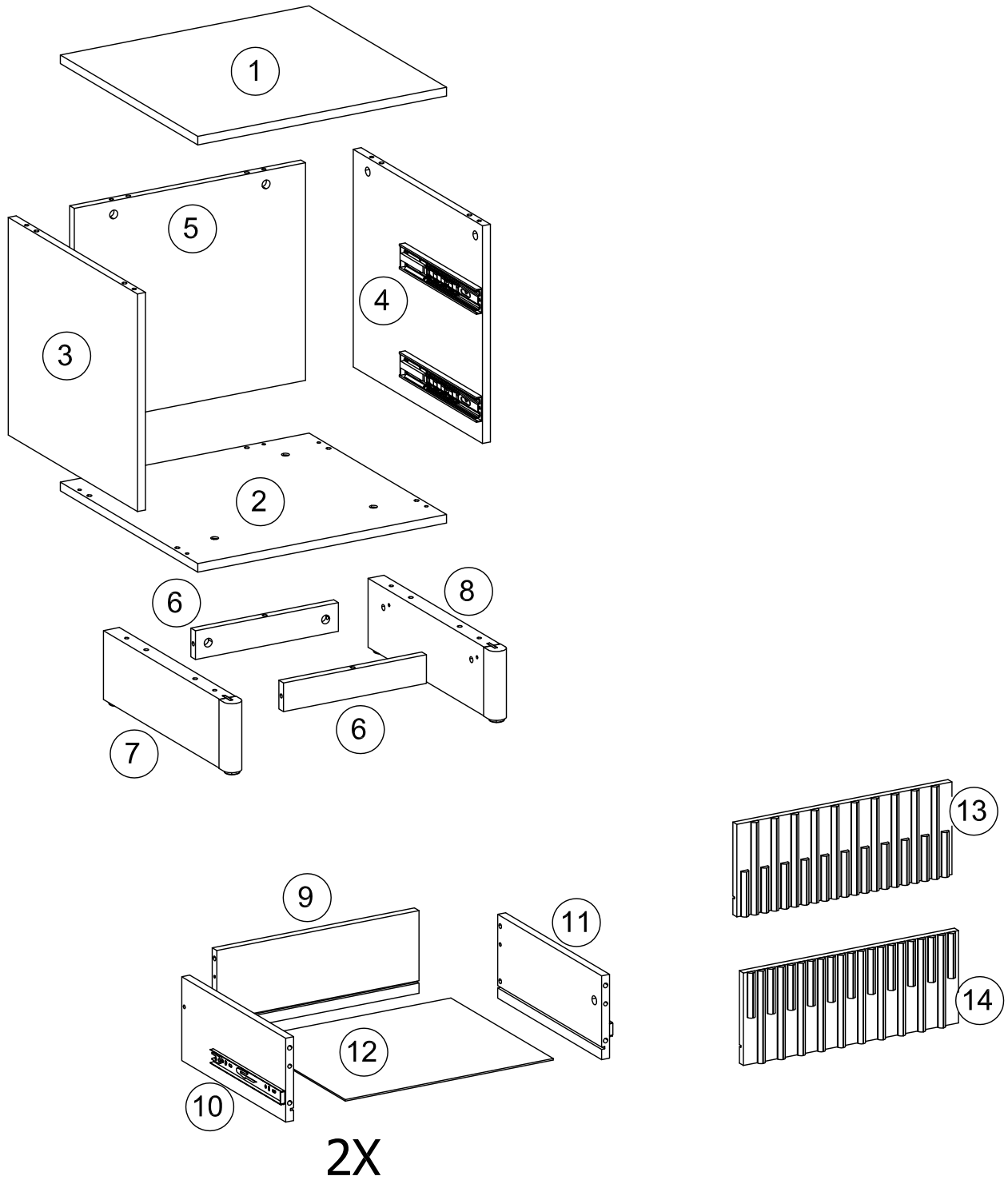

WARNING

The Furniture is Exempt From Our Home Approval Policy Once Assembled.

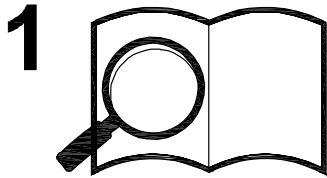

Read the Assembly Instruction carefully, check that all Parts and Hardwares are present !

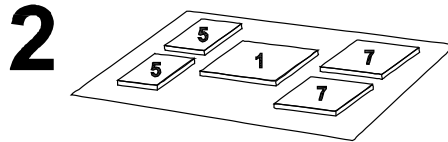

Layout all of the parts on a soft surface, and separate in groups for the same numbers to prevent any damage and easy identification. (Note: protected surface required for High Gloss Finished Items).

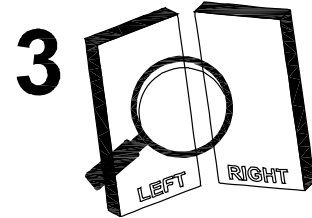

Carefully identify each parts required on that step, especially those that are similar. (e.g., Left-Right).

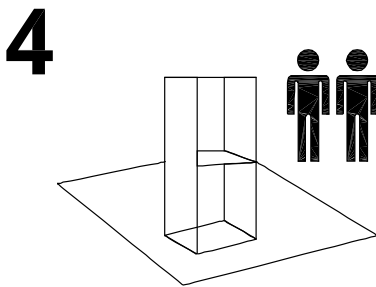

Please ensure you have sufficient space and people (as indicated in Page 1) to assemble the product safely.

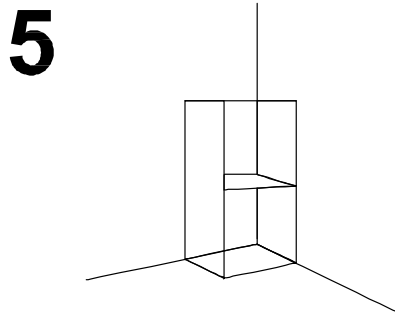

Where possible, all items are assembled near to the area in which they will be place in use, to avoid moving the product unnecessary once assembled.

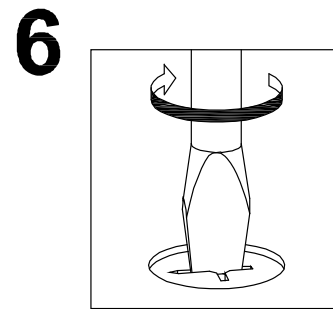

During assembly please take care not to over-tighten any fittings, as this may damage the product.

Note : For faster assembly strongly recommended to assemble sub-assembly part before the main body (e.g. drawer, hutch).

CAM-BOLT

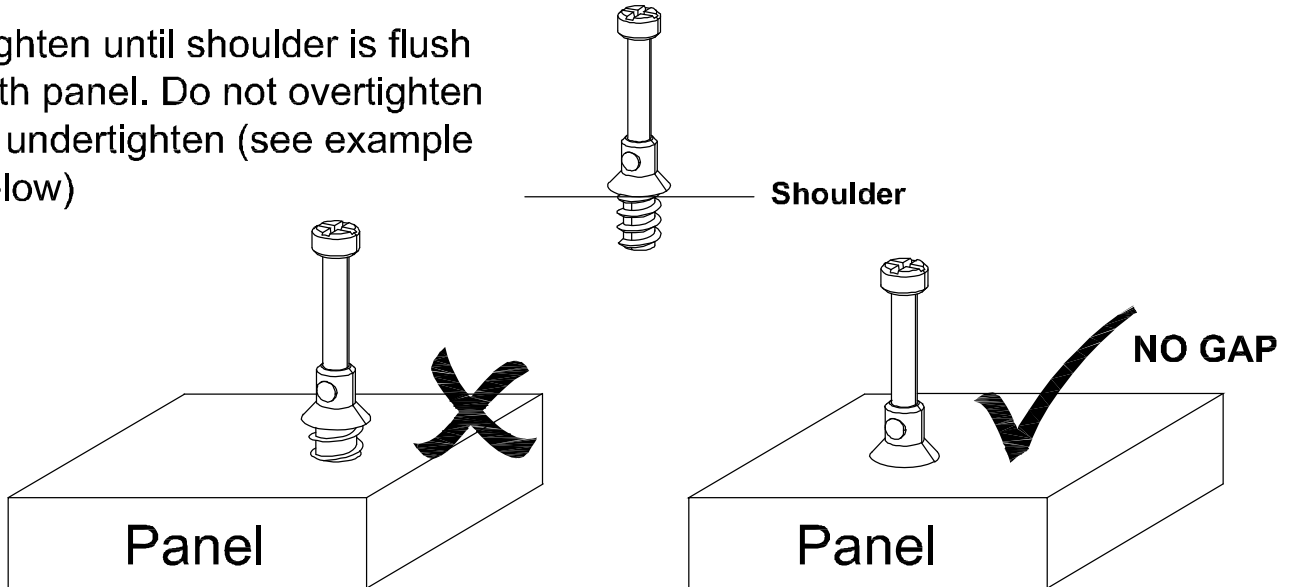

Tighten until shoulder is flush with panel. Do not overtighten or undertighten (see example below)

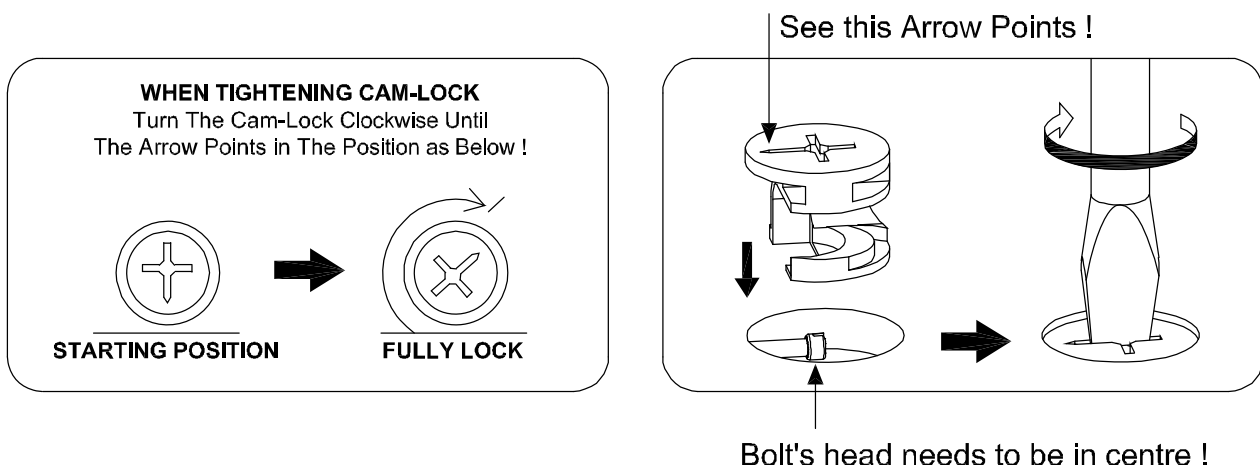
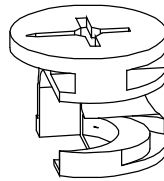

CAM-LOCK

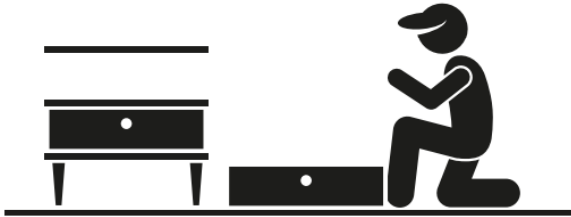
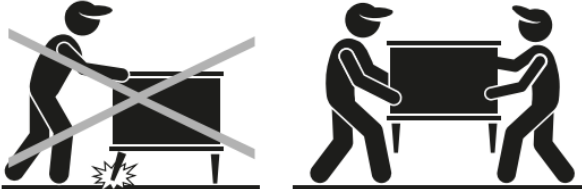

Assembly instructions.

	<p>ALWAYS lay each panel down on a clean and level area, ideally in the room of intended use, ensuring there is enough room to maneuver around the item.</p>
	<p>NEVER pull furniture into place as this causes damage to the internal structure and feet fixings. Always lift to move.</p>
	<p>NEVER flip your upholstery allowing corners to hit the floor as structural damage can be caused. Always turn gently.</p>

1

1 x 1	3 x 1	4 x 1	A x 4	B x 6	D x 8	
-------	-------	-------	-------	-------	-------	--

2

2X

5 x 1	6 x 2	A x 6	D x 6	
-------	-------	-------	-------	--

3

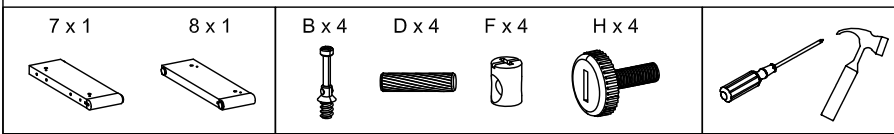
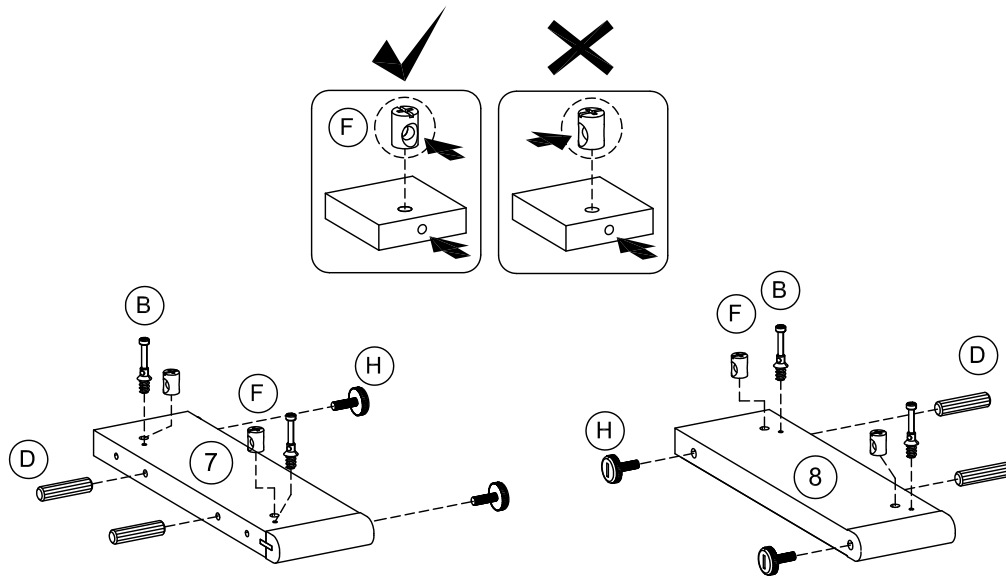

4

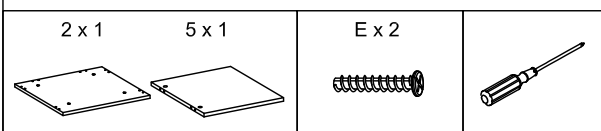
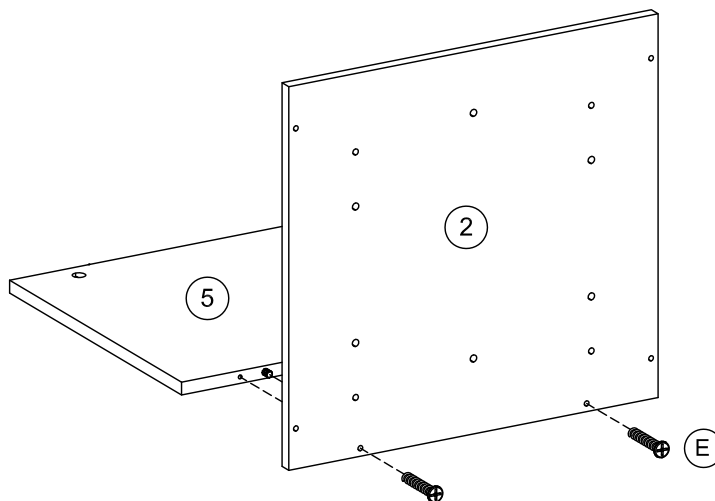

5

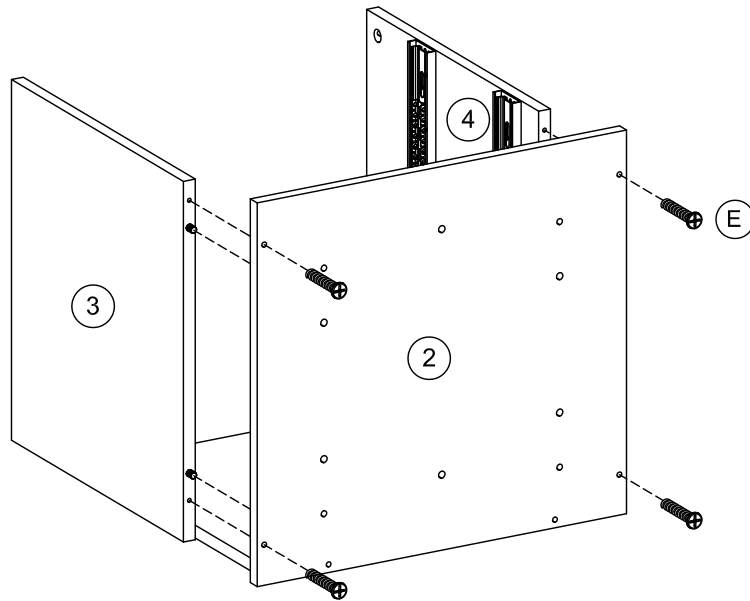

3 x 1

4 x 1

E x 4



6

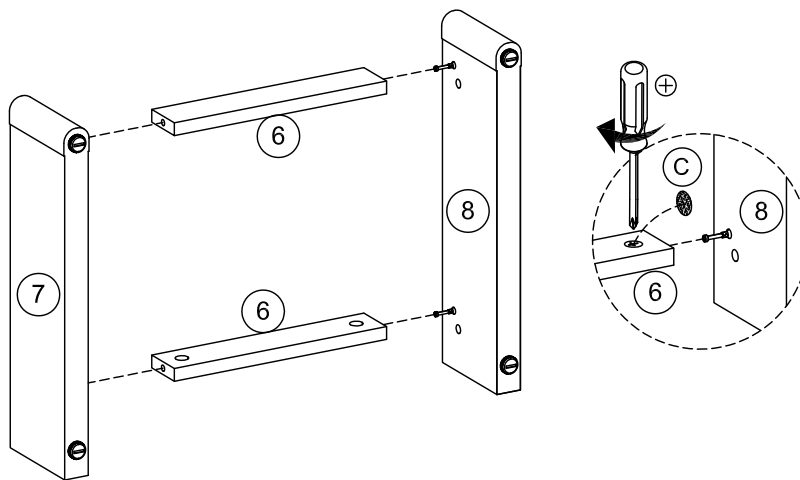

6 x 2

7 x 1

8 x 1

C x 4

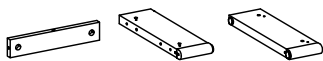

7

STEP 2

STEP 1

C x 4

G x 4

I

8

1 x 1

C x 6

9

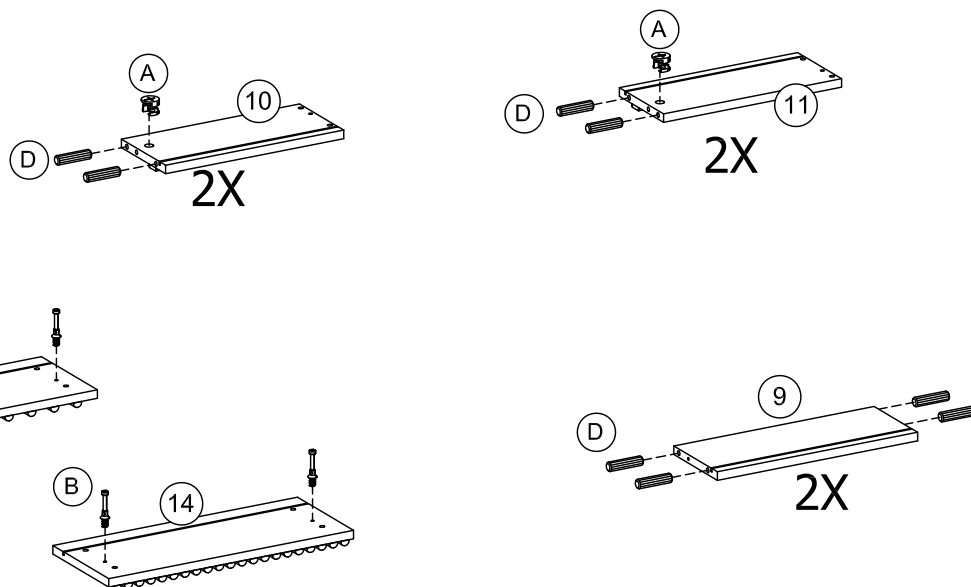

9 x 2	10 x 2	11 x 2	13 x 1	14 x 1	A x 4	B x 4	D x 16	

10

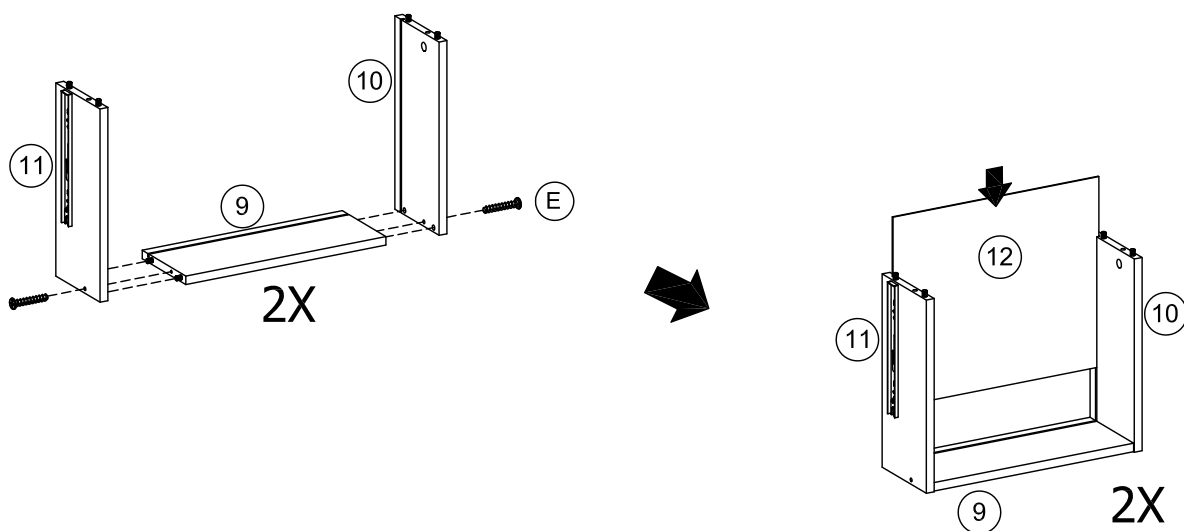

9 x 2	10 x 2	11 x 2	12 x 2	E x 4	

11

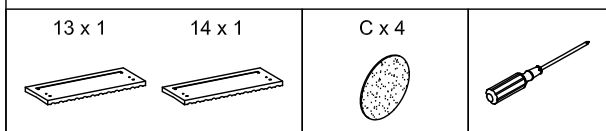
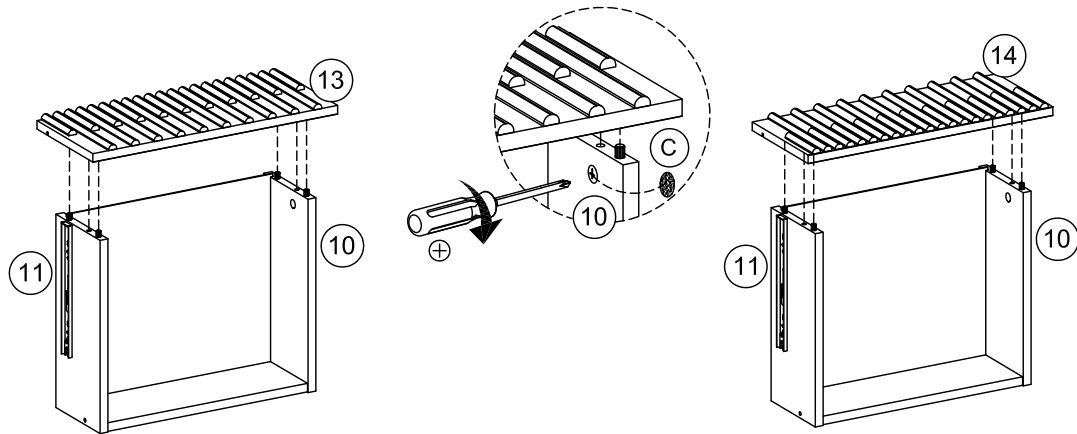

12

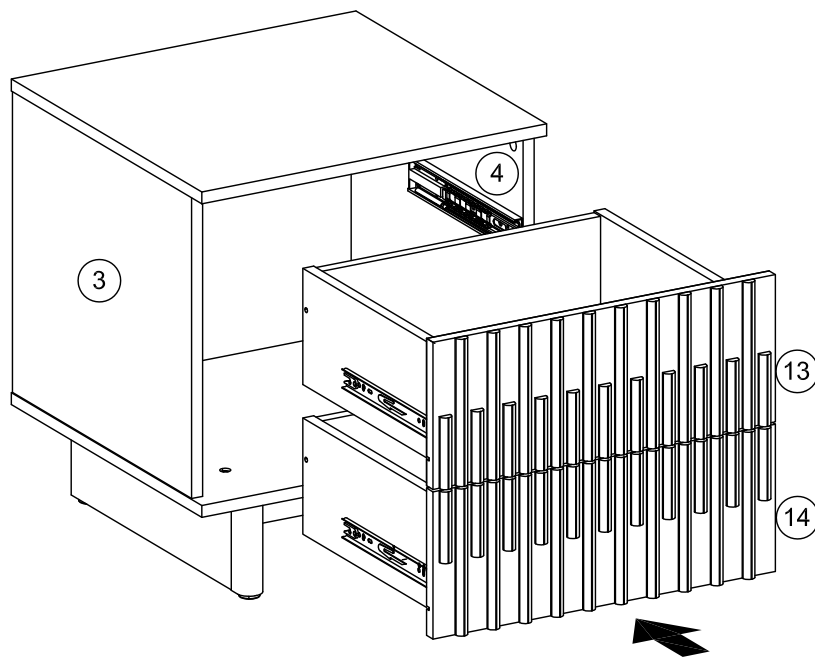

13

Scenario A.

If the gaps increase from left to right...

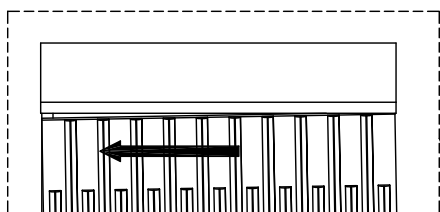

...increase height of the front left foot (1) by unscrewing it so the foot moves towards the ground

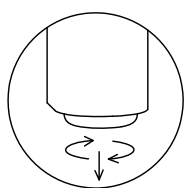

Scenario B.

If the gaps increase from right to left...

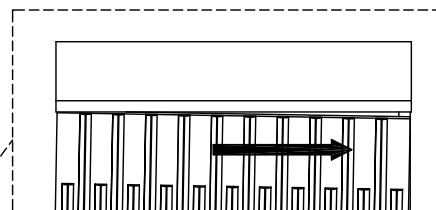

...increase height of the front right foot (2) by unscrewing it so the foot moves towards the ground

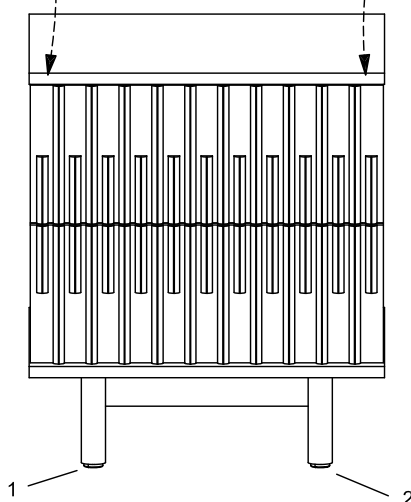
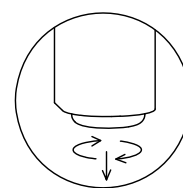

Move the bedside into its location of intended use next to a wall. Turn the adjustable feet so the bedside is level (you can use a spirit level to help here).

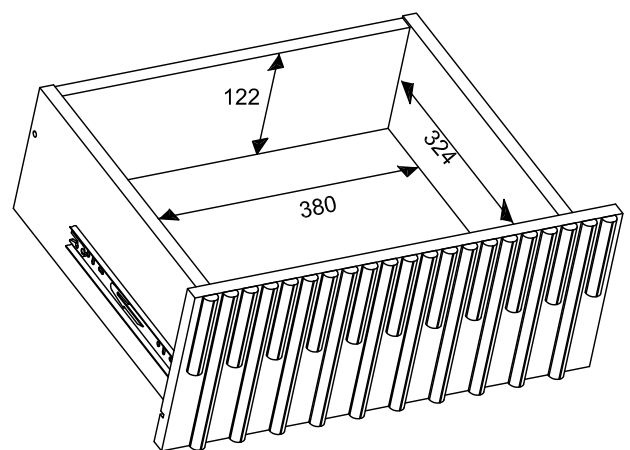
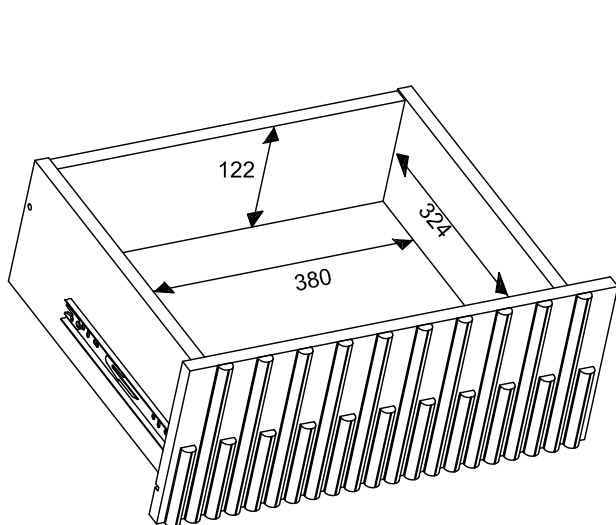
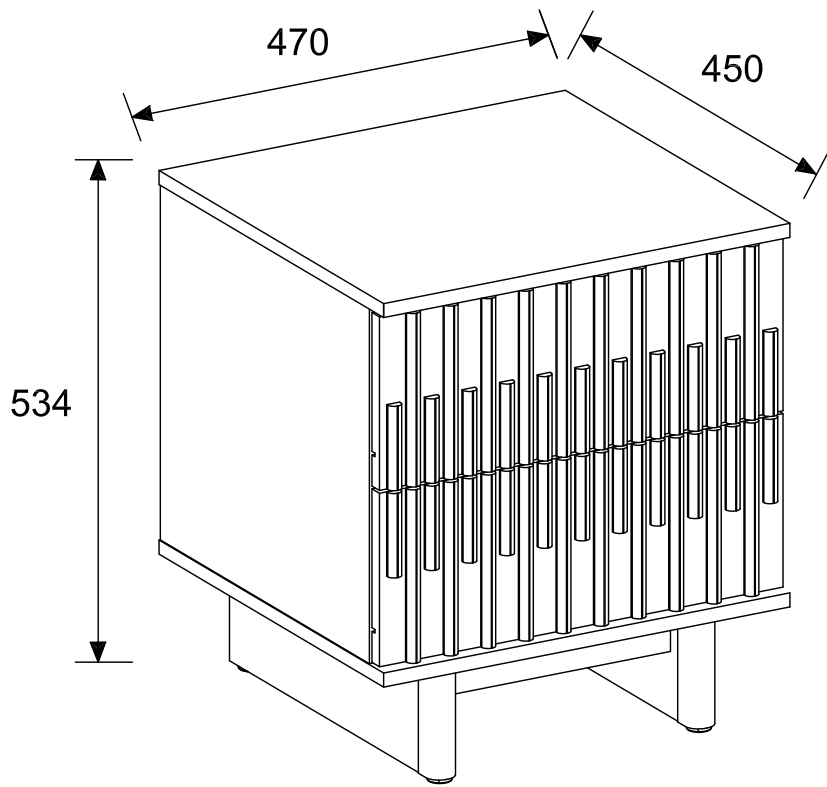

General furniture care.

- Uneven floors could give the impression that doors are out of alignment or that the furniture is wobbly. Be aware of this and compensate, if necessary, by adjusting the hinges or packing a corner to level the item. Please refer to the assembly instructions and adjust accordingly.
- If your furniture becomes stained, scratched, chipped or suffers other damage, we recommend professional help is sought to restore it. Please contact our customer services line for recommended agents.
- **DO** move items such as ornaments or coasters around periodically to allow the colour to mellow evenly.
- **DO** use mats and coasters to protect the surface from heat, liquids, or items that may cause scratches.
- **DO** ensure plastic or felt feet protectors are securely fitted into place on the feet and legs to avoid scratches.
- **DO** check fittings and fixings from time-to-time and tighten when necessary. Stop using the product if still unstable after all screws and bolts are tightened.
- **DO NOT** drag your furniture when moving it as this can damage joints. Always lift furniture into place.

Foil Care

- **DO** avoid water or other liquids contacting scratches or chips as this can cause the surface to bubble and lift.
- **DO** only clean using a damp cloth and mild detergent. Aim to dust weekly with a soft, lint-free cloth or duster to prevent any build up of dirt.
- **DO** remove any spills immediately to avoid staining.
- **DO NOT** place directly in front of heat sources such as radiators or fires as timber can be affected by temperature and humidity which may cause cracking and warping.
- **DO NOT** in direct sunlight, as this will cause the colour to change quickly.
- **DO NOT** use bleach or abrasive cleaners.
- **DO NOT** use too much water when cleaning, the cloth should just be slightly damp.
- **DO NOT** use abrasive polish or silicon-based polishes as these can affect the finish over time.

Customer service.

If you have any issues with this product, you can call our Customer Service team on:
0345 165 6565 Monday to Friday **9am to 5:00pm**.

Alternatively, you can contact our team by Live Chat on: **Dunelm.com**
Monday to Friday 8am – 8:30pm
Saturdays 8am – 5:30pm
Sundays and bank holidays 9am – 4:30pm.



Dunelm (Soft Furnishings) Ltd. LE7 1AD
& Dunelm (Soft Furnishings) Holdings
Ltd. Dublin D12 WR25.