

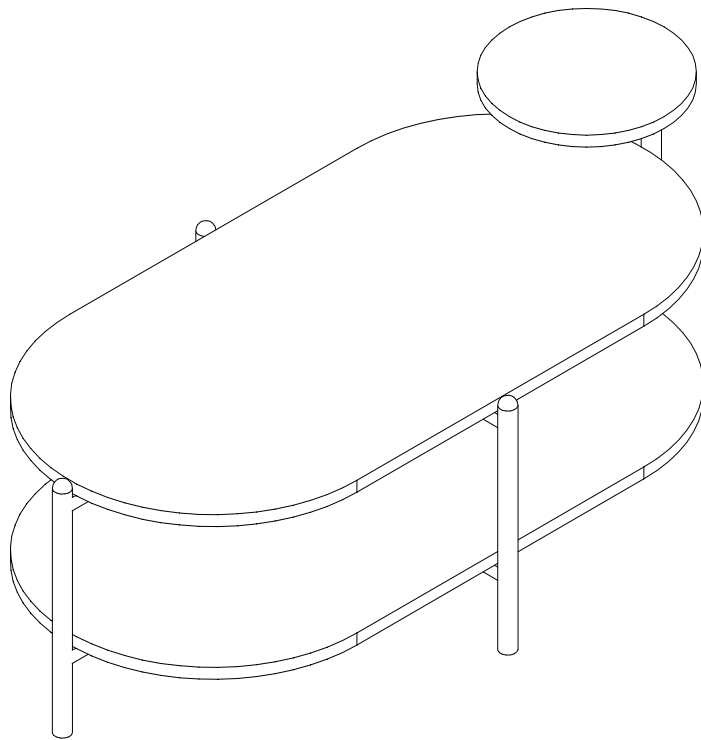

Tessy

Swivel Coffee Table

Assembly & Care Instructions



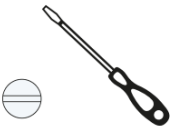



1. Check you have received all parts listed on the component and hardware pages and the correct quantity of each. Beware that sometimes parts are packaged within the product so not immediately visible after opening. Please check the assembly section for more details. If anything is missing, stop assembling the product and contact our customer service team.
2. Check all parts are intact and undamaged. Any issues, stop assembling the product and contact our customer service team.
3. Check you have the right tools for the job. Required tools which are not provided are listed below. If you are unsure of how to use these tools, please contact a professional tradesperson. We recommend Airtasker as an easy way to find trades people in your local area.

Tools required which are not included					
Flat head screwdriver	Cross head screwdriver	Drill			
					

Safety advice.

Dear Customer

- **IMPORTANT** - The first step you need to take is to ensure your safety! Please take the time to read and understand these instructions before assembling the product.
- Please keep these instructions for future reference.
- This item is intended for indoor use only – unless otherwise specified. Avoid exposure to humid conditions.
- Assembly to be carried out by a competent adult only.
- During assembly children should be kept away from the product due to possible risk of injury. The product may contain small parts that could also cause choking if swallowed.
- Products can be dangerous if incorrectly installed or assembled. Assembly should be carried out by a competent person and instructions followed. No liability will be accepted for damage or injury caused by incorrectly installed or assembled products.
- Never use an electric drill to assemble a product, as this can cause damage to parts.
- Regularly check all fastenings to ensure that they are properly tightened.
- Restrain children from climbing or playing on or around the product. Always consider where products are positioned to ensure children cannot get access to long cords or windows.
- Some products will be supplied with anti - tip kits which should always be used to secure the product to the wall and prevent tipping.
- Keep all plastic wrapping materials away from babies and children to avoid danger of suffocation.
- Ensure that all packaging is disposed of carefully and responsibly. Please recycle where possible.
- Once items are part or fully assembled, they are not returnable unless faulty.

Max weight limit	No. of people to assemble	Assembly difficulty	Time to assemble
			
75 KG	1 recommended	Moderate	<1 hour

Ref	Dimensions(mm)	Visual	Qty
1	1000x500x18		1
2	1000x500x18		1
3	270x270x18		1
4	∅25x380		3
5	∅25x520		1

Hardware supplied.

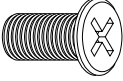
Ref	Hardware & dimension (mm)	Qty
A		4
B		16

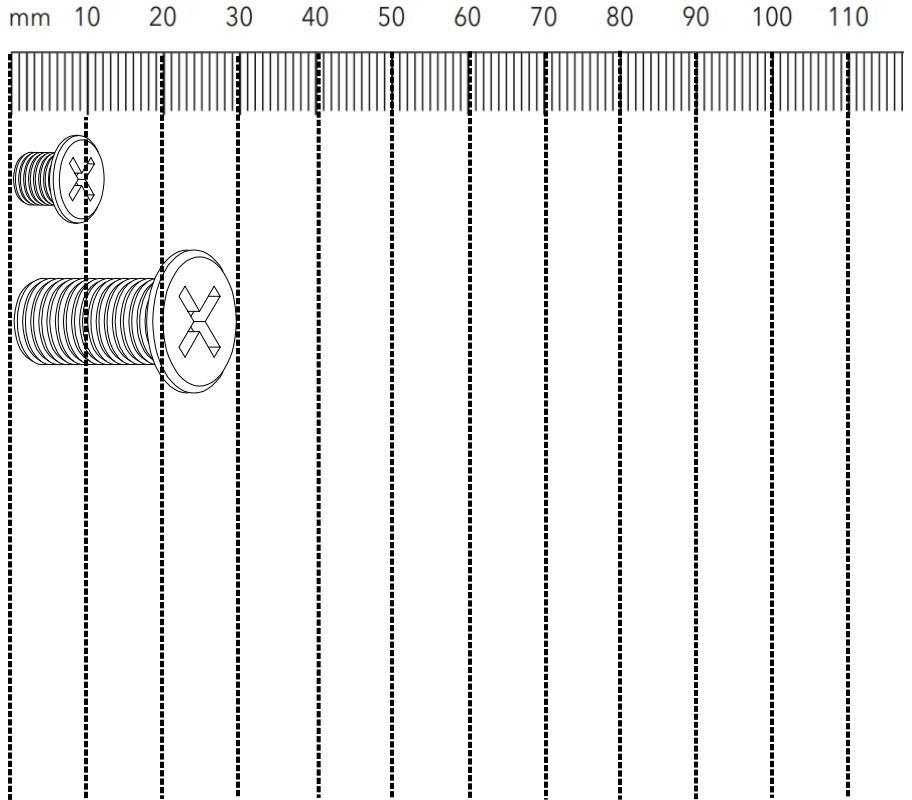

Hardware supplied.

A	M6x12mm	4pcs	B	M6x30mm	16pcs

Exploded diagram.

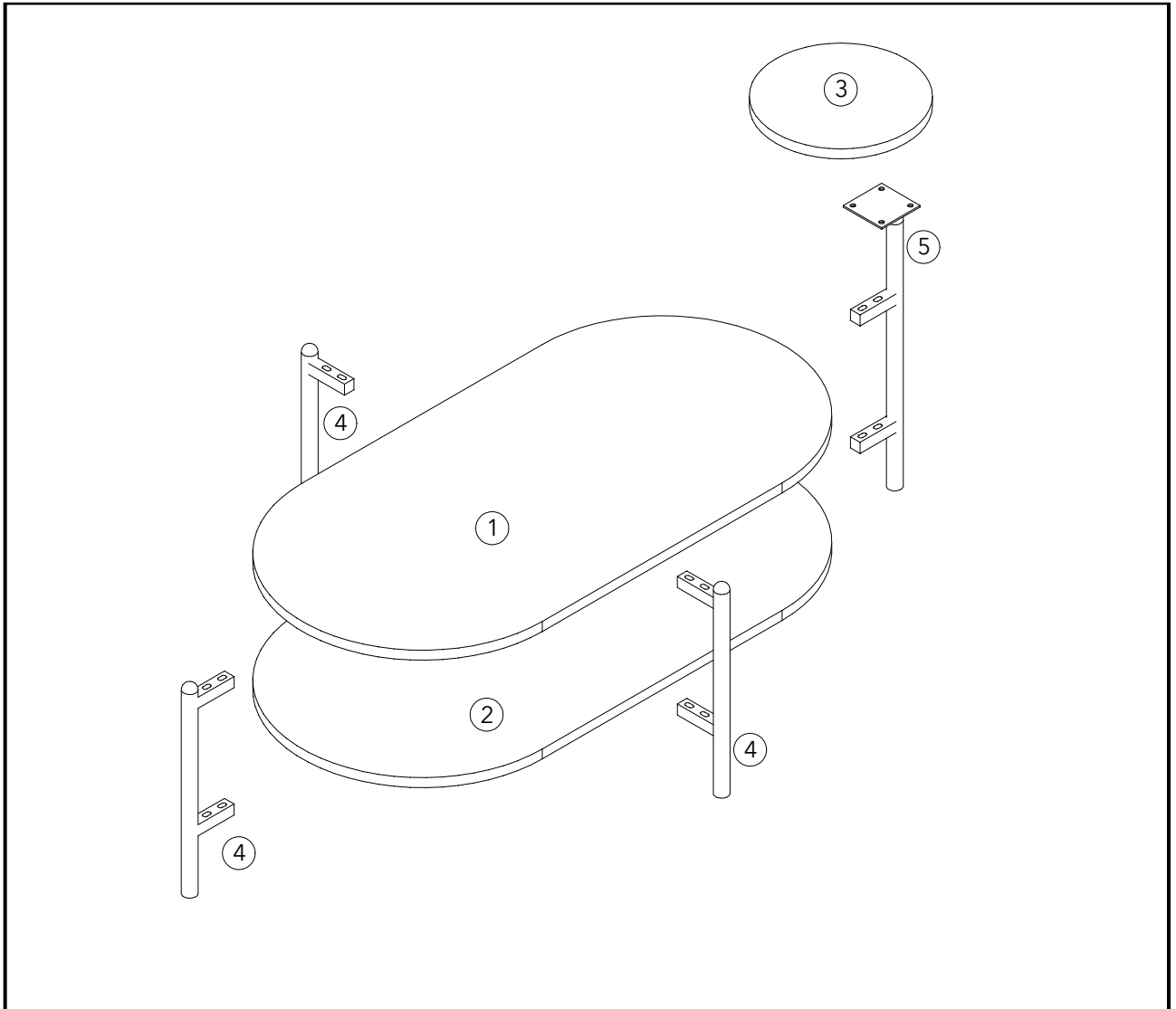

If you are unsure of the below guidance, consult a qualified tradesperson for advice or help.

- Wall fixings are not provided with this product as different wall types require different screws and wall plugs. See table below as a guide only.
- Always use a wall plug, as screws alone will not be secure into walls.
- As a general rule, always use a larger screw and wall plug if you are not sure.
- When drilling into walls always check there are no hidden wires or pipes.
- Make sure that the screws and wall plugs are suitable for supporting the weight of the product.
- Ensure you use the recommended drill bit to match the required hole size for the wall plug. Wall plugs must fit tightly into the drilled hole.
- Ensure you drill the hole horizontally, do not force the drill or enlarge the hole.
- Take extra care when drilling high walls.
- Ensure the plug is fitted below the ceramic tile to avoid splitting or cracking

Care and Maintenance.

- Regularly check the fixings to ensure the wall plug or screws have not become loose. Tighten or stop using the product if they have.

Wall plug types		
<p>You can use one of the following types of wall plug if your walls are made of brick, breeze block, concrete, stone, wood or plastic board.</p>		
General Purpose	Plasterboard	Hammer
<p>For light loads only. Options available for most wall types.</p>	<p>For light loads only. Attach into plasterboard.</p>	<p>For light loads only. For solid walls covered with plasterboard. Allows the fixing to be attached into brick behind.</p>
Cavity - Light load	Cavity - Heavy load	Shield Anchor
<p>Light load cavity wall plug for use into plasterboard or hollow wooden doors.</p>	<p>Heavy load cavity wall plug for use into plasterboard or hollow wooden doors.</p>	<p>For heavier loads into masonry, brickwork or concrete.</p>

WARNING! Tipping hazard

Unanchored products can tip over which can lead to serious or fatal crushing injuries. We therefore recommend anchoring this product to the wall using the enclosed anti-tip kit.

The anti-tip kit has been provided for your safety.

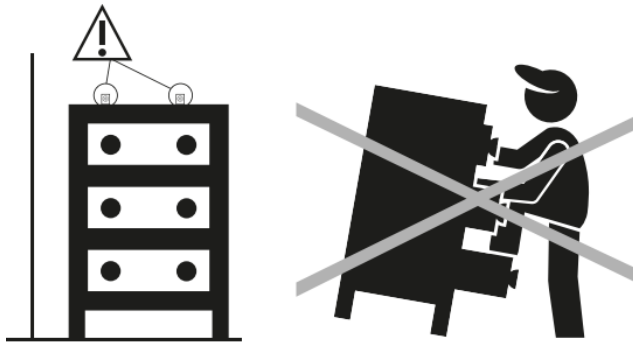

IMPORTANT - Keep these instructions for future reference

- This product is supplied with an anti-tip kit which must be fitted to prevent tipping. This has been provided for your safety.
- Never leave a child unattended around the product.
- Never allow children to climb, hang or pull at the product.
- If in doubt, please consult a qualified tradesperson to properly fit the anti-tip kit.
- Wall fixings are not provided with the anti-tip kit as different wall types require different screws and wall plugs. See wall fixing guide within this document for guidance.
- Make sure the screws and wall plugs used are suitable for your wall type and that they can support the weight of the product. Consult a qualified tradesperson if unsure.
- Before drilling into walls, always check there are no hidden wires or pipes behind.
- We recommend 2 people install heavy products.

Fixing the anti-tip kit

Plastic Cable Tie

- Position the product where desired. Looking at the hooks on the back of the product, mark appropriate positions for the plastic wall brackets to be fixed, bearing in mind the length of the cable ties. When happy, screw the plastic bracket to the wall using appropriate wall screws and plugs for your wall type.
- Attach the cable tie through the product hook and wall bracket. Ensure the plastic tie is securely fastened and the product is held in place. Do not continue to use the product if the cable tie does not secure properly.
- The product will now be secured to the wall to prevent tipping.

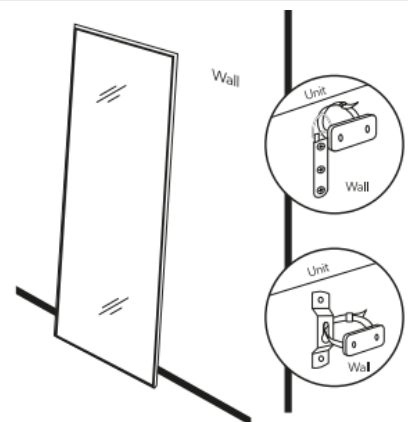

Metal Bracket

- Using the product screws provided and the appropriate wall screws and plugs for your wall type, secure the L bracket to the wall and the product as illustrated by the diagram.
- The product will now be secured to the wall to prevent tipping.

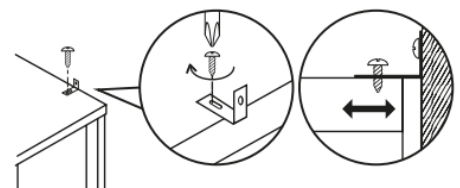

	<p>ALWAYS lay each panel down on a clean and level area, ideally in the room of intended use, ensuring there is enough room to maneuver around the item.</p>
	<p>NEVER pull furniture into place as this causes damage to the internal structure and feet fixings. Always lift to move.</p>
	<p>NEVER flip your upholstery allowing corners to hit the floor as structural damage can be caused. Always turn gently.</p>

1

B x 8

2

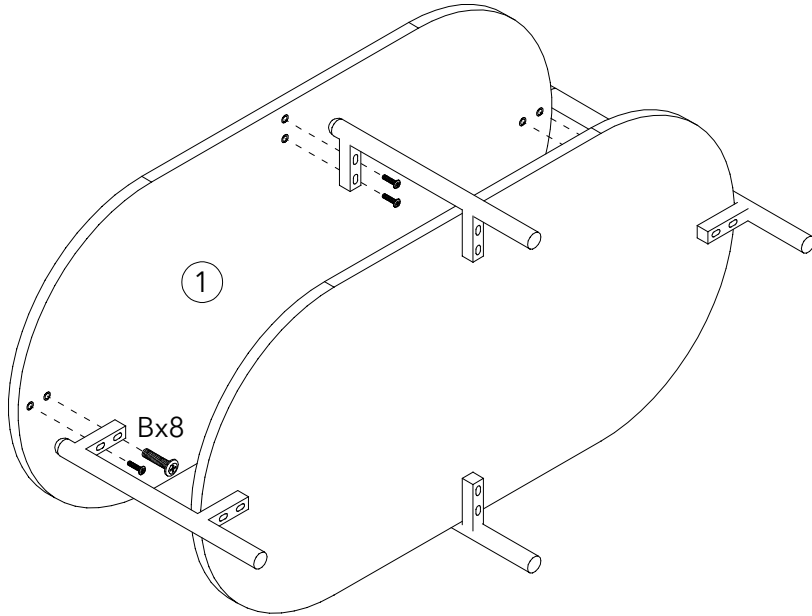

B x 8

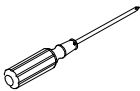

3

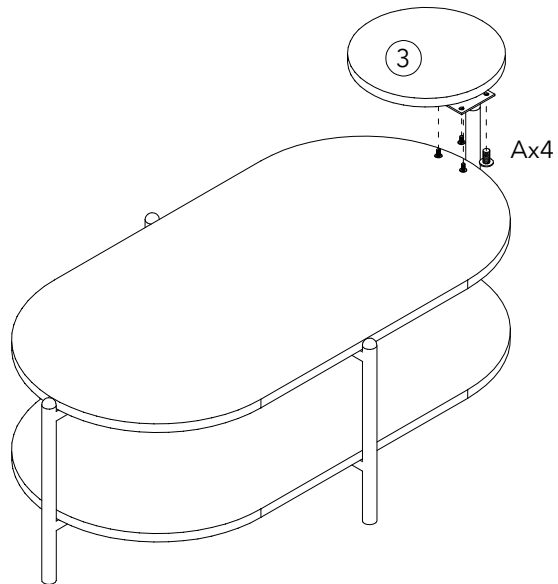

A x 4



4

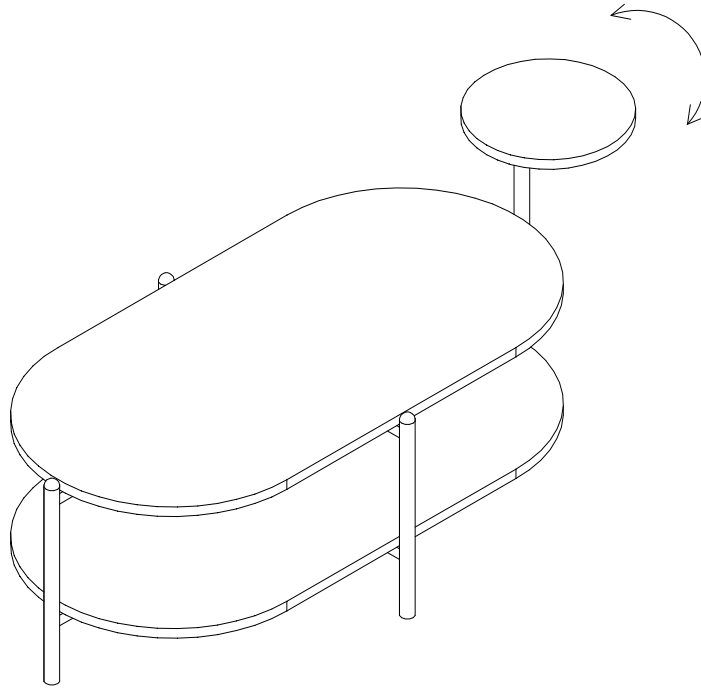



Do not sit or stand on this product.
Do not place heavy objects on this product.
The maximum load on horizontal surfaces
is 15 kg.

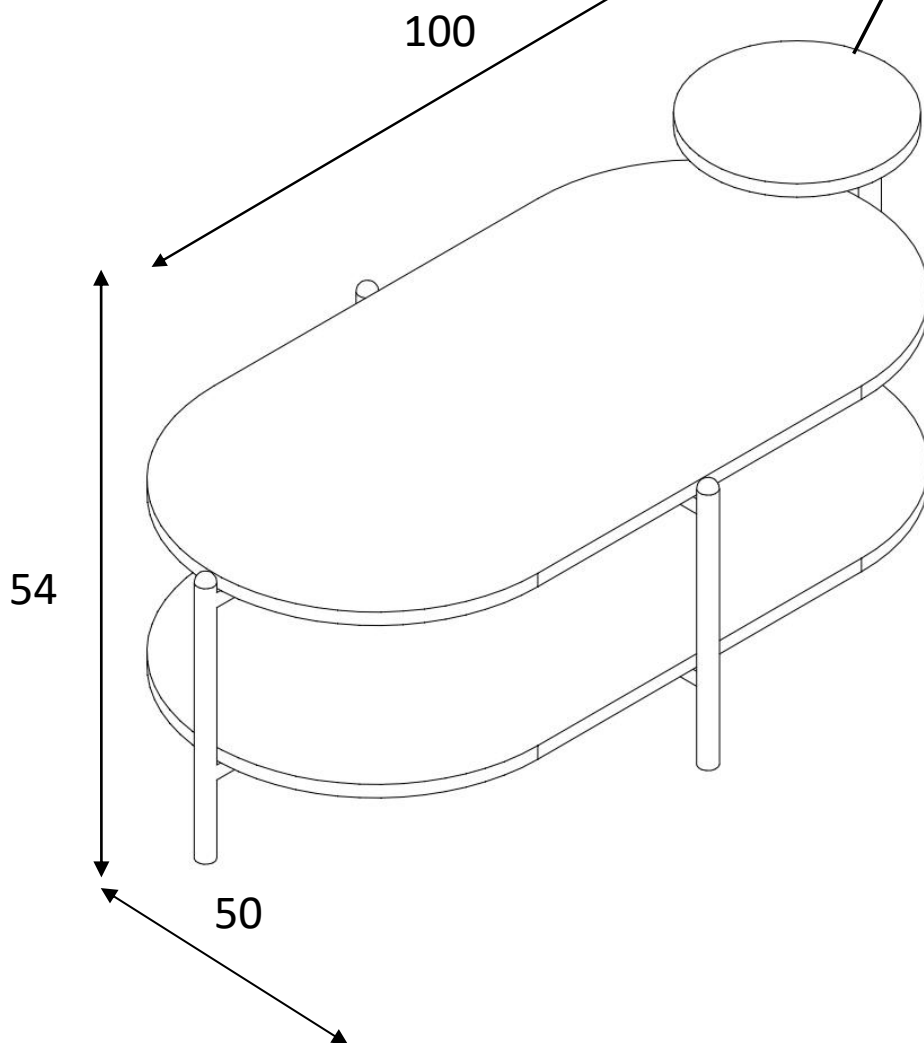

- Uneven floors could give the impression that doors are out of alignment or that the furniture is wobbly. Be aware of this and compensate, if necessary, by adjusting the hinges or packing a corner to level the item. Please refer to the assembly instructions and adjust accordingly.
- If your furniture becomes stained, scratched, chipped or suffers other damage, we recommend professional help is sought to restore it. Please contact our customer services line for recommended agents.
- **DO** move items such as ornaments or coasters around periodically to allow the colour to mellow evenly.
- **DO** use mats and coasters to protect the surface from heat, liquids, or items that may cause scratches.
- **DO** ensure plastic or felt feet protectors are securely fitted into place on the feet and legs to avoid scratches.
- **DO** check fittings and fixings from time-to-time and tighten when necessary. Stop using the product if still unstable after all screws and bolts are tightened.
- **DO NOT** drag your furniture when moving it as this can damage joints. Always lift furniture into place.

Foil Care

- **DO** avoid water or other liquids contacting scratches or chips as this can cause the surface to bubble and lift.
- **DO** only clean using a damp cloth and mild detergent. Aim to dust weekly with a soft, lint-free cloth or duster to prevent any build up of dirt.
- **DO** remove any spills immediately to avoid staining.
- **DO NOT** place directly in front of heat sources such as radiators or fires as timber can be affected by temperature and humidity which may cause cracking and warping.
- **DO NOT** in direct sunlight, as this will cause the colour to change quickly.
- **DO NOT** use bleach or abrasive cleaners.
- **DO NOT** use too much water when cleaning, the cloth should just be slightly damp.
- **DO NOT** use abrasive polish or silicon-based polishes as these can affect the finish over time.

Marble Care

- As a soft stone, marble can be susceptible to chips, cracks, scratches, and discoloration, so it's important to care for it properly.
- **DO** clean with a damp cloth using warm water or a specialist marble cleaner, then buff to dry.
- **DO** remember that marble surfaces are porous, so it's crucial to remove spillages immediately to avoid stains, and we recommend using coasters and place mats to protect against heat and moisture.
- **DO NOT** use abrasive or acidic cleaners, chemicals and regular furniture polishes on marble as they can cause damage.
- **DO NOT** let acidic substances come directly into contact with the marble, for example lemon juice.
- **DO NOT** use marble surfaces as a chopping board or work top and do not place heavy weights on it.
- **DO NOT** sit or stand on a marble surface.

Timber Care

- Timber is a natural material and each piece is individual.
- Colour may mellow over time and new items can vary in shade from items that you have purchased previously.
- **DO** only clean using a damp cloth and mild detergent. Aim to dust weekly with a soft, lint-free cloth or duster to prevent any build up of dirt.
- **DO** ensure the polish you are using is correct for your product and finish.
- **DO** avoid getting furniture wet when mopping floors. Always move out of the way when possible.
- **DO** patch test polishes or cleaning products on a small discreet area before applying across the whole unit.
- **DO** remove any spills immediately to avoid staining.
- **DO NOT** place directly in front of heat sources such as radiators or fires as timber can be affected by temperature and humidity which may cause cracking and warping.
- **DO NOT** place timber product in direct sunlight, as this will cause the colour to change quickly.
- **DO NOT** use bleach or abrasive cleaners.
- **DO NOT** use abrasive polish or silicon-based polishes as these can affect the finish over time.

Glass & Mirror Care

- Mirrors are a potential fire hazard. Keep out of direct sunlight.
- Handle with care.
- Always supervise young children around glass products.
- If the glass is chipped or broken, stop using the product.
- It is not recommended that glass or mirrored items to be positioned over heat sources such as radiators.
- **DO** clean your item, using a soft cloth slightly dampened with water and wipe clean. Then buff with a dry clean cloth. Use washing up liquid if necessary.
- **DO** only use fixings provided with the product.
- **DO** stop using the product if the glass is chipped or broken.
- **DO NOT** place very hot or very cold items directly on glass surfaces. Adequate table mats can be used to prevent such items coming into direct contact with the furniture.
- **DO NOT** sit or stand on glass surfaces.
- **DO NOT** use glass as a chopping board.
- **DO NOT** strike the glass with hard or pointed items or use the glass as a chopping surface.
- **DO NOT** use abrasives cleaning agents, as these may scratch the glass.
- **DO NOT** install this product in a damp environment such as a bathroom or outside, unless the product specifies otherwise, as this may cause the product to warp and become damaged.

Customer service.



If you have any issues with this product, you can call our Customer Service team on:
0345 165 6565 Monday to Friday **9am to 5:00pm.**

Alternatively, you can contact our team by Live Chat on: **Dunelm.com**
Monday to Friday 8am - 8:30pm
Saturdays 8am - 5:30pm
Sundays and bank holidays 9am - 4:30pm.



Dunelm (Soft Furnishings) Ltd. LE7
1AD & Dunelm (Soft Furnishings)
Holdings Ltd. Dublin D12 WR25.