

Assembly Instructions

Product size:
W70*D70*H74 CM

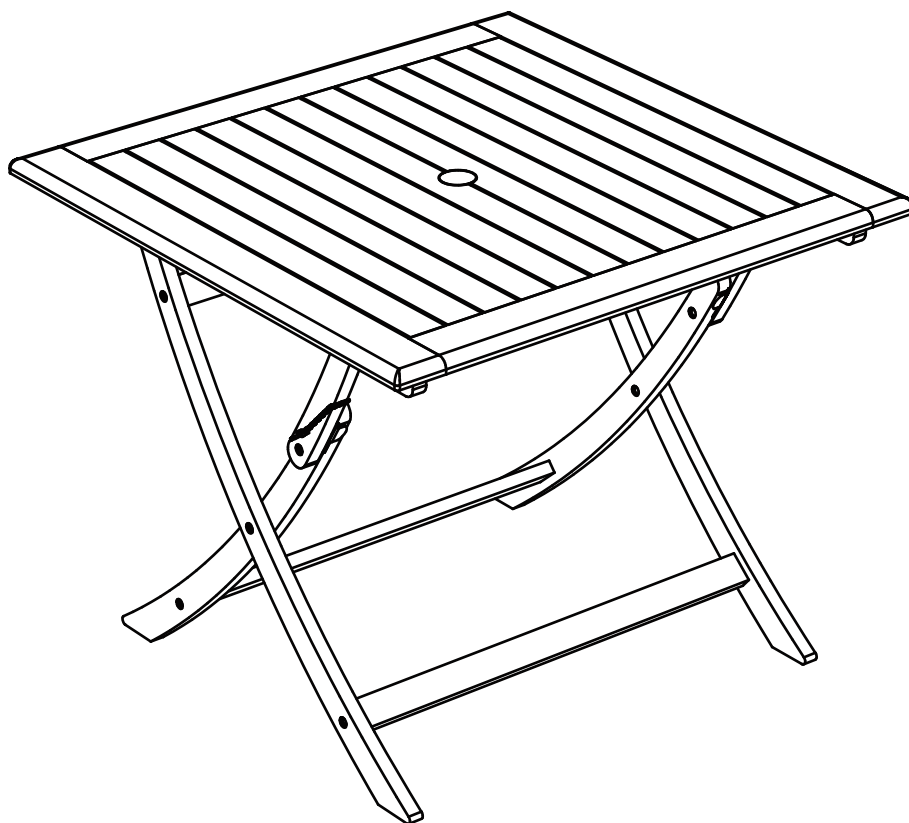

Furniture should be covered/stored whilst not in use to prolong its longevity.
(It should also be covered in adverse weather.)

This product is for domestic use only.

**IMPORTANT, PLEASE RETAIN FOR FUTURE REFERENCE
READ CAREFULLY**

Before you start



Warnings

IMPORTANT, RETAIN FOR FUTURE REFERENCE READ CAREFULLY

See enclosed instructions for assembly, safety and care information.

Failure to follow the warnings could result in serious injury.

Handle heavy parts with care.

Ensure that this product is fully assembled as illustrated before use.

This product should only be used on firm, level ground.

The product contains small parts which could pose a risk to young children. Keep small parts out of reach of children.

Do not stand or climb onto this product.

This product is intended for **domestic use** only.

Ensure the product is always placed on level ground.

Furniture can be dangerous if incorrectly used. No liability will be accepted for damage or injury caused by incorrect use of this product.

Take care when opening and folding furniture. Keep your hands away from moving parts in order to prevent trapping your fingers. Children should not open or close the furniture.

This table is not intended to support a parasol separately. A parasol base with suitable weight must be used to support your parasol.



Dos

When you are ready to start, make sure that you have the right tools, plenty of space and a clean, dry area for assembly.

Unwrap all packaging materials and place the components on suitable surface to prevent scratching your product.

Check the pack and make sure you have all of the parts listed. In the event of problems or missing parts, please contact the seller.

Check all screws and bolts are tightened and inspect regularly.

During severe weather conditions, including high winds, rain, hail, thunderstorms, extreme heat and cold temperatures, the product should be stored inside in a cool, dry place.

To best preserve this product, please use a protective cover when your furniture is not in use. We would also recommend using a gazebo or parasol over your furniture during the summer period and prolonged sunny spells. This will help prevent harmful UV rays from damaging and discolouring the material.

Timber is a natural product and contains coloured resins which may initially bleed out of the timber when its gets wet. Therefore we recommend that care is taken to protect patios and decking from possible staining where the product comes into contact with the ground. The furniture will stabilise in its environment after the first few times it gets wet.

Wood is a natural material whose appearance will deteriorate when left outside. A surface coating is vital in protecting it from premature darkening, or splitting, when exposed to the weather. The finish should be regularly maintained to ensure that the wood is protected from moisture and the furniture continues to look at its best.

This product has been treated with furniture oil during manufacture and the wood requires further treatment before being left outside. When applying furniture oil particular care should be given to the end grain and any joints or crevices.

Should you choose not to treat your furniture, then it will turn a greyish colour and develop cracks. Light sanding can restore the original colour after which furniture oil can be regularly applied in accordance with the instructions above.

A liberal coating of furniture oil should be given to the furniture before it is laid up, and again when it is removed from storage.

Clean your product with a sponge and warm soapy water then wipe with a clean, dry cloth.

Ensure that the product is clean and dry before storage.

Where instructions as to the; storage, commissioning, installation, use and maintenance of the goods or (if there is none) good trade practice are not followed and a defect arises this will void the 12 month manufacturer's guarantee on the product.

X Don'ts

Do not use scourers, abrasives, washing powders, chemical cleaners or any other substances containing abrasives since these substances can damage the product.

To preserve the product do not place greasy / oily items directly onto the wooden surface.

Do not place very hot or very cold items on the wooden surface unless adequately thick place-mats are used to prevent such items from coming into contact with the wood.

Do not strike the product with hard or pointed items.

Do not sit or lean on the arms of this product.

Do not use power tools to construct this product.

Do not tighten screws until fully assembled.

Do not overtighten screws or bolts.

Do not use this product if parts are missing, damaged or worn.

Do not stand or climb onto the product and do not use it as a ladder, as this could lead to it unbalancing and overturning.

Never tilt the product during use.

Never drag furniture when moving it, always lift it.

Number of people required for assembly

Two people



Time to assemble

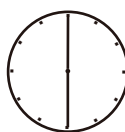

30 minutes











Tools required

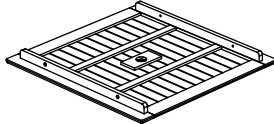

LONDON 70CM SQUARE FOLDING BISTRO TABLE

ITEM CODE: LON-70T

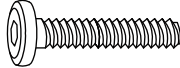
Components, fixtures & fittings (not actual size)

Parts List					
Part No.	Diagram	Qty.	Part No.	Diagram	Qty.
A	 Table Leg	1 PC	B	 Table Leg	1 PC
C	 Folding Table Leg	1 PC	D	 Folding Table Leg	1 PC
E	 Long Connecting Bar	2 PCS	F	 Short Connecting Bar	1 PC
			H	 Table Top	1 PC
I	 Parasol Hole Cap	1 PC	ST50	 Self-Tapping Screw M7*50mm	6 PCS
1	 Male Bolt M8*30mm	6 PCS	2	 Washer	6 PCS

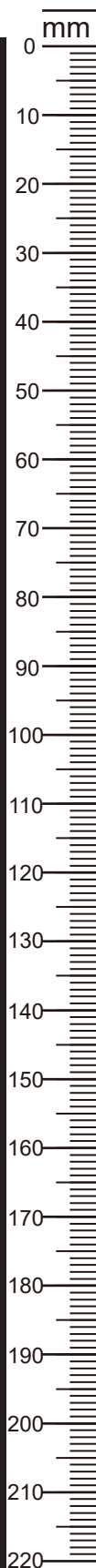

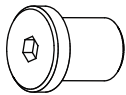
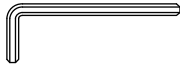
3	 Female Bolt M8x15mm	6 PCS	AK	 Allen Key	2 PCS
---	---	-------	----	---	-------

Step by step assembly instructions

Step One

With the help of another person, open the cartons, place the Table Top (H) upside down on a flat, non-abrasive and soft platform to avoid scratching the table surface or rim.

Attach the Long Connecting Bars (E) between the Table Legs (A & B) using Self-Taping Screws (ST50).

Attach the Short Connecting Bar (F) between the Folding Table Legs (C & D) using Self-Taping Screws (ST50).

Tighten with Allen Key (AK).

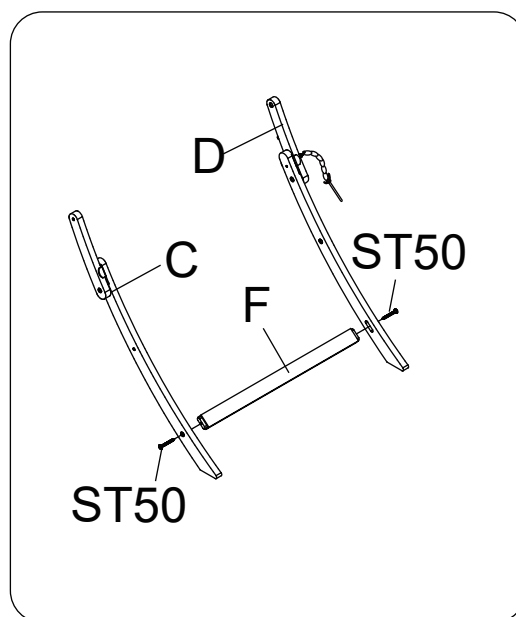
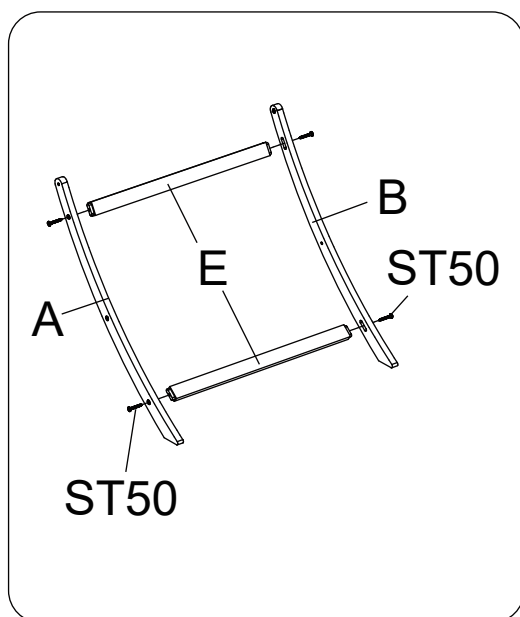
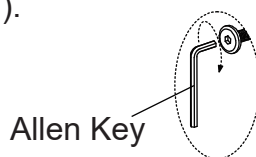

Step Two

Attach the Folding Table Legs (C & D) into the Table Legs (A & B) using Male Bolts (1), Washers (2) and Female Bolts (3).

Please note the Location of the Washers is between the Table Legs.

Tighten with Allen Key (AK).

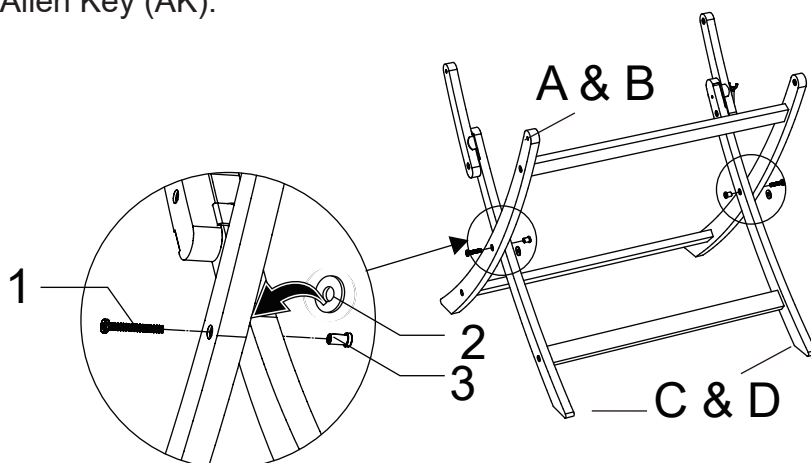

Step Three

Attach the Table Legs (A & B) and Folding Table Legs (C & D) to the Table Top (H) using Male Bolts (1), Washers (2) and Female Bolts (3).

Please note the Location of the Washers is between the components.

Tighten with Allen Key (AK).

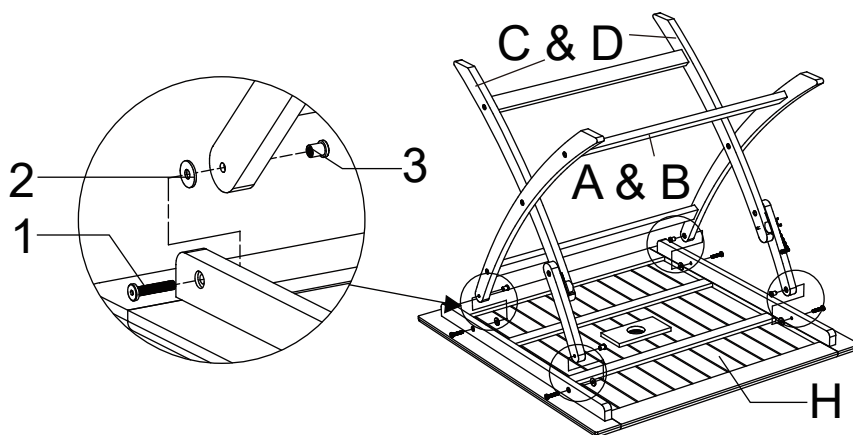

Step Four

With the help of another person, stand the table.

Place the Parasol Hole Cap (I) to the table top.

Use the Chained Pin to lock the Folding Leg.

Your table is now ready for use.

Please note this Chained Pin should be released if you would like to fold the Table.

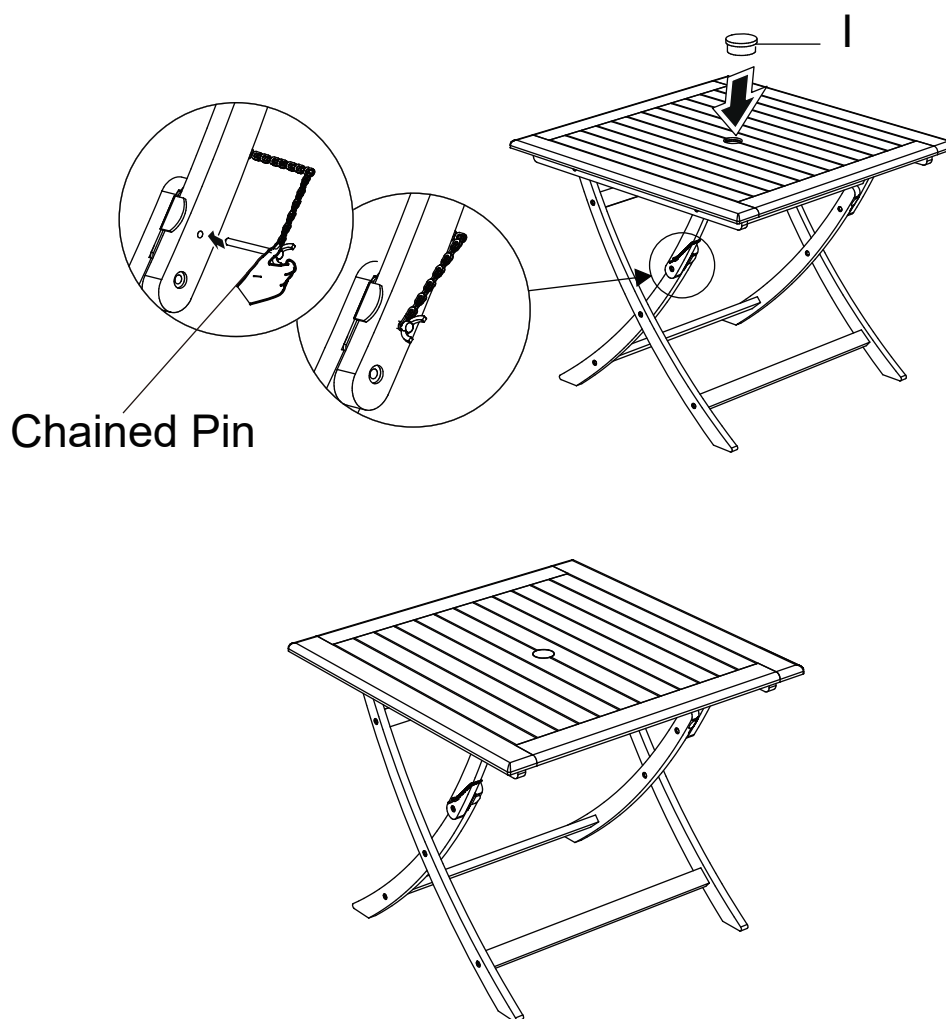

**This table is not intended to support a parasol separately.
A parasol base with suitable weight must be used to support your parasol.**

PLEASE KEEP THESE INSTRUCTIONS FOR FUTURE REFERENCE

General Furniture Care & Maintenance

The key to the longevity of your new furniture is maintenance. Regular cleaning is essential and the required frequency depends on factors such as furniture location, sun, salt, dust, moisture & pollution. These factors can affect the look of your furniture. Please follow the instructions below to help protect the look and life span of your furniture.

If stored during winter/wet season, ensure furniture is stored in a cool well-ventilated area to help prevent excessive shrinkage or expansion of the timber due to humidity. When making repairs ensure to prepare area properly.

Clean the damaged area first from dirt & dust. Shake wood preservative and then apply with required brush. Depending on the size of the damaged area, wait 6-12 hours before using furniture. To reduce maintenance, a furniture cover is recommended.

Cleaning

To clean furniture, simply wash with soapy water using a soft cloth or a soft non-metallic brush. Rinse with fresh water and dry with soft clean cloth.

Cleaning frequency will depend on location but the rule of thumb is once a month for external areas and two to three times a year for fully protected furniture.

Fabric Care

Keep fabrics dry. Vacuum regularly and avoid leaving in direct sunlight for long periods of time. Spot clean using mild soapy water and a soft cloth/sponge to affected area. Once clean, rinse with fresh water and pat dry with a soft cloth. Ensure fabrics and foam fillers are allowed to fully dry out before use.

Do not use solvents. Do not dry-clean or machine wash. For stubborn stains, commercially available fabric cleaners are available.

Strictly follow application instructions on product before use and it is recommended to test on a hidden area first.

Steam cleaners can be used but ensure cushion covers remain on the inserts and use the "Gentle" setting on the appliance.

**IMPORTANT, PLEASE RETAIN FOR FUTURE REFERENCE
READ CAREFULLY**

Step by Step Maintenance Process

Your Furniture has already been treated at the point of manufacturing. No treatment is necessary for at least 3 Months. Only when you start to see signs of weathering, it is time then to proceed to the following maintenance steps to get your furniture looking good again.

There is no immediate need to apply treatment to the wood upon purchase, as it has already been coated during the manufacturing process. However, as the wood begins to weather over time, it is recommended to lightly sand the surface and then apply a water-based oil preservative to maintain its appearance and protect it from the elements.

1. Clean the Surface: Start by cleaning the furniture to remove dust, dirt, or grease. Use a damp cloth or mild soap solution, then wipe it dry with a clean cloth. Allow the surface to dry completely before proceeding.

2. Sand the Surface: Sand the wood lightly with 220-grit sandpaper to smooth out the surface and remove any old finish. This will also help the Wood Oil adhere better. After sanding, wipe the furniture with a tack cloth to remove all dust and debris.

3. Apply the First Coat of Wood Oil:

1) Stir the Oil: We recommend using a clear water-based wood oil for the treatment of this furniture.

2) Apply the Oil: Using a small sponge, dab a thin, even coat of wood oil, working with the grain of the wood. Make sure to avoid drips or thick spots. If your product has rope material, do not apply any oil to this and wash it off immediately using luke-warm soapy water. If using a brush, apply in long, smooth strokes.

3) Let it Dry: Allow the first coat to dry according to the manufacturer's instructions. Typically, a water-based wood oil takes about 2 hours to dry.

4. Sand between Coats:

Once the first coat is dry, lightly sand the surface with 320-grit sandpaper. Sanding between coats helps to smooth out any imperfections or dust particles and provides a better surface for the next layer.

Wipe the surface with a tack cloth after sanding to remove all dust.

5. Apply Additional Coats:

Apply the Second Coat: Apply a second thin coat of wood oil using the same method as before.

Repeat Sanding: After the second coat dries, sand light with 320-grit sandpaper again and wipe clean with a tack cloth. If you want a more durable finish, you can apply additional coats (typically 3-4 coats total).

Tips:

Ventilation: Ensure you're working in a well-ventilated area.

Avoid over-brushing: Don't over-brush the oil as it can create bubbles or streaks. Apply a thin, smooth layer and let it level out on its own.

Drying Time: Let each coat fully dry before applying the next.

By following these steps. You will create a professional looking finish on your hardwood furniture that enhances its durability and beauty.

**IMPORTANT, PLEASE RETAIN FOR FUTURE REFERENCE
READ CAREFULLY**

Step by Step Maintenance Process

Your Furniture has already been treated at the point of manufacturing. No treatment is necessary for at least 3 Months. Only when you start to see signs of weathering, it is time then to proceed to the following maintenance steps to get your furniture looking good again.

There is no immediate need to apply treatment to the wood upon purchase, as it has already been coated during the manufacturing process. However, as the wood begins to weather over time, it is recommended to lightly sand the surface and then apply a water-based oil preservative to maintain its appearance and protect it from the elements.

1. Clean the Surface: Start by cleaning the furniture to remove dust, dirt, or grease. Use a damp cloth or mild soap solution, then wipe it dry with a clean cloth. Allow the surface to dry completely before proceeding.

2. Sand the Surface: Sand the wood lightly with 220-grit sandpaper to smooth out the surface and remove any old finish. This will also help the Wood Oil adhere better. After sanding, wipe the furniture with a tack cloth to remove all dust and debris.

3. Apply the First Coat of Wood Oil:

1) Stir the Oil: We recommend using a clear water-based wood oil for the treatment of this furniture.

2) Apply the Oil: Using a small sponge, dab a thin, even coat of wood oil, working with the grain of the wood. Make sure to avoid drips or thick spots. If your product has rope material, do not apply any oil to this and wash it off immediately using luke-warm soapy water. If using a brush, apply in long, smooth strokes.

3) Let it Dry: Allow the first coat to dry according to the manufacturer's instructions. Typically, a water-based wood oil takes about 2 hours to dry.

4. Sand between Coats:

Once the first coat is dry, lightly sand the surface with 320-grit sandpaper. Sanding between coats helps to smooth out any imperfections or dust particles and provides a better surface for the next layer.

Wipe the surface with a tack cloth after sanding to remove all dust.

5. Apply Additional Coats:

Apply the Second Coat: Apply a second thin coat of wood oil using the same method as before.

Repeat Sanding: After the second coat dries, sand light with 320-grit sandpaper again and wipe clean with a tack cloth. If you want a more durable finish, you can apply additional coats (typically 3-4 coats total).

Tips:

Ventilation: Ensure you're working in a well-ventilated area.

Avoid over-brushing: Don't over-brush the oil as it can create bubbles or streaks. Apply a thin, smooth layer and let it level out on its own.

Drying Time: Let each coat fully dry before applying the next.

By following these steps. You will create a professional looking finish on your hardwood furniture that enhances its durability and beauty.

**IMPORTANT, PLEASE RETAIN FOR FUTURE REFERENCE
READ CAREFULLY**