

XRocker.

CARBON-TEK
BY XRocker

2 DOORS WARDROBE BLACK/RED

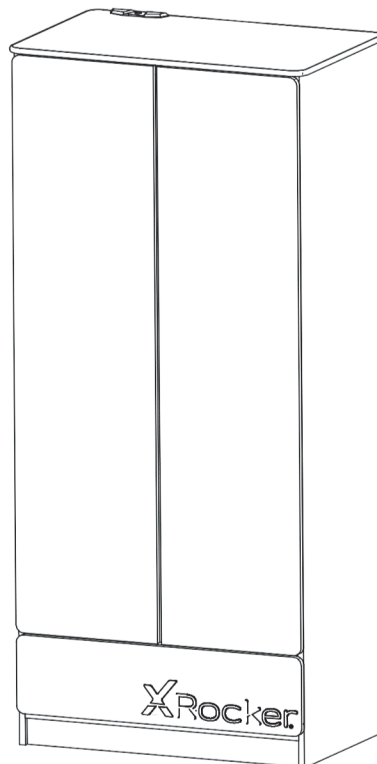

Size: 79x51.5x181.5cm(WDH)

NEED SUPPORT?



SCAN THIS QR CODE
OR VISIT
WWW.XRockerUK.COM

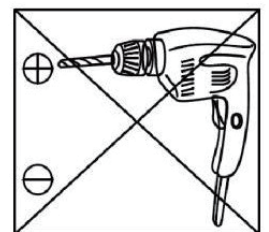

PLEASE READ this sheet prior to assembly to familiarise yourself with the various stages of construction.

Carefully open the pack supplied and check the contents against the parts and fittings check list. Do not destroy any of the packaging until you are certain that you have all the necessary parts for the assembly.

CAUTION: There are small components used in the construction of this unit. These loose items should be kept away from young children whilst assembling your unit to avoid the danger of choking.

Not Provided

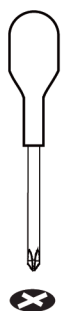

Not Provided

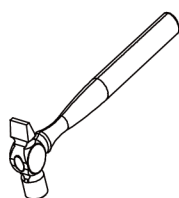

Tools Required

Number of people



Page 1



2 Hours Set Up



**ENGLISH -ASSEMBLY INSTRUCTIONS
IMPORTANT - READ CAREFULLY -
RETAIN THESE INSTRUCTIONS FOR
FUTURE REFERENCE
INFORMATION**

- This product is designed to hold 60Kg in total. Do not exceed this weight.
 - We recommend that this unit is assembled in the room intended for use.
 - When you are ready to start, make sure that you have the right tools, plenty of space and a clean, dry area for assembly.
 - Unwrap all packaging materials and place each component on top of the carton box or on a clean floor to prevent it from scratching.
 - Check the pack and make sure you have all the parts listed.
 - Ensure that this product is fully assembled as illustrated before use.
 - Check all screws or bolts are tightened and inspect regularly.
 - Tools are not included unless specified in the parts list.
- WARNINGS**
- This product should only be used on a firm and level floor.
 - Keep small parts out of reach of children.
 - Make sure the legs/base remain in contact with the floor.
 - DO NOT use power tools to construct this product.
 - DO NOT tighten screws until parts are assembled or as advised in this guide.
 - DO NOT over tighten screws or bolts.
 - DO NOT use this product if parts are missing, damaged or worn.
 - DO NOT climb, sit or stand on the product.
 - The product must be filled using of wall straps provided to avoid accidents and possible fatal injuries if the item falls over or tips over during use.
 - If wall fixings are supplied, always ensure the wall area to be drilled is free of electrical wires, water and gas pipes. The wall fixing supplied are suitable for solid walls. For other types of wall suitable fixings must be obtained separately. If in doubt, please consult a qualified tradesperson.
- CARE INFORMATION**
- Never use scourers, abrasives, or chemical cleaners.
 - To clean, wipe with a damp sponge and warm soapy water. Do not use solvent-based cleaners or detergents as they can bleach or damage the product.

**FRANÇAIS - INSTRUCTIONS DE
MONTAGE
IMPORTANT - LIRE ATTENTIVEMENT -
CONSERVER CES INSTRUCTIONS POUR
RÉFÉRENCE ULTÉRIEURE
INFORMATIONS**

- Ce produit est conçu pour contenir 60 kg au total. Ne dépassez pas ce poids.
 - Nous recommandons que cet appareil soit assemblé dans la pièce prévue pour l'utilisation.
 - Lorsque vous êtes prêt à commencer, assurez-vous d'avoir les bons outils, beaucoup d'espace et une zone propre et sèche pour l'assemblage.
 - Déballez tous les matériaux d'emballage et placez chaque composant sur le dessus de la boîte en carton ou sur un sol propre pour éviter qu'il ne se raye.
 - Vérifiez l'emballage et assurez-vous que vous disposez de toutes les pièces répertoriées.
 - Assurez-vous que ce produit est entièrement assemblé comme illustré avant utilisation.
 - Vérifiez que toutes les vis ou tous les boulons sont bien serrés et inspectez-les régulièrement.
 - Les outils ne sont pas inclus, sauf indication contraire dans la liste des pièces.
- AVERTISSEMENT**
- Ce produit ne doit être utilisé que sur un sol ferme et de niveau.
 - Gardez les petites pièces hors de portée des enfants.
 - Assurez-vous que les pieds/la base restent en contact avec le sol.
 - N'UTILISEZ PAS d'outils électriques pour construire ce produit.
 - NE serrez PAS les vis tant que les pièces ne sont pas assemblées ou comme indiqué dans ce guide.
 - NE PAS trop serrer les vis ou les boulons.
 - NE PAS utiliser ce produit si des pièces sont manquantes, endommagées ou usées.
 - NE PAS grimper, s'asseoir ou se tenir debout sur le produit.
 - Le produit doit être rempli à l'aide des sangles murales fournies pour éviter les accidents et d'éventuelles blessures mortelles si l'article tombe ou se renverse pendant l'utilisation.
 - Si des fixations murales sont fournies, assurez-vous toujours que la zone du mur à percer est exempte de fils électriques, de conduites d'eau et de gaz. Les fixations murales fournies conviennent aux murs pleins. Pour les autres types de murs, des fixations appropriées doivent être obtenues séparément. En cas de doute, veuillez consulter un professionnel qualifié.

INFORMATIONS D'ENTRETIEN

- N'utilisez jamais de tampons à récurer, d'abrasifs ou de nettoyants chimiques.
- Pour nettoyer, essuyer avec une éponge humide et de l'eau chaude savonneuse. N'utilisez pas de nettoyants ou de détergents à base de solvants car ils peuvent blanchir ou endommager le produit.

**DEUTSCH - MONTAGEANLEITUNG
WICHTIG - SORGFÄLTIG LESEN -
BEWAHREN SIE DIESE ANLEITUNG ZUM
SPÄTEREN NACHSCHLAGEN AUF
INFORMATION**

- Dieses Produkt ist für ein Gesamtgewicht von 60 kg ausgelegt. Überschreiten Sie dieses Gewicht nicht.
 - Wir empfehlen, dieses Gerät in dem Raum zu montieren, in dem es verwendet werden soll.
 - Wenn Sie bereit sind zu beginnen, vergewissern Sie sich, dass Sie über die richtigen Werkzeuge, ausreichend Platz und einen sauberen, trockenen Bereich für die Montage verfügen.
 - Packen Sie alle Verpackungsmaterialien aus und legen Sie jede Komponente auf den Karton oder auf einen sauberen Boden, um Kratzer zu vermeiden.
 - Überprüfen Sie die Packung und vergewissern Sie sich, dass alle aufgeführten Teile vorhanden sind.
 - Stellen Sie vor der Verwendung sicher, dass dieses Produkt wie abgebildet vollständig zusammengebaut ist.
 - Überprüfen Sie, ob alle Schrauben oder Bolzen festgezogen sind, und führen Sie regelmäßige Inspektionen durch.
 - Werkzeuge sind nicht enthalten, sofern nicht in der Teileliste angegeben.
- WARNUNGEN**
- Dieses Produkt sollte nur auf einem festen und ebenen Boden verwendet werden.
 - Bewahren Sie Kleinteile außerhalb der Reichweite von Kindern auf.
 - Stellen Sie sicher, dass die Beine/Basis in Kontakt mit dem Boden bleiben.
 - Verwenden Sie KEINE Elektrowerkzeuge, um dieses Produkt zu konstruieren.
 - Ziehen Sie die Schrauben NICHT fest, bis die Teile zusammengebaut sind oder wie in dieser Anleitung empfohlen.
 - Schrauben oder Bolzen NICHT zu fest anziehen.
 - Verwenden Sie dieses Produkt NICHT, wenn Teile fehlen, beschädigt oder abgenutzt sind.
 - Klettern, sitzen oder stehen Sie NICHT auf dem Produkt.
 - Das Produkt muss mit den mitgelieferten Wandlaschen gefüllt werden, um Unfälle und möglicherweise tödliche Verletzungen zu vermeiden, wenn das Produkt während des Gebrauchs umfällt oder umkippt.
 - Wenn Wandbefestigungen geliefert werden, stellen Sie immer sicher, dass der zu bohrende Wandbereich frei von elektrischen Leitungen, Wasser- und Gasleitungen ist. Die mitgelieferten Wandbefestigungen sind für Massivwände geeignet. Für andere Wandarten müssen geeignete Befestigungen separat erworben werden. Wenden Sie sich im Zweifelsfall an einen Fachhandwerker.
- PFLEGE INFORMATIONEN**
- Verwenden Sie niemals Scheuermittel, Scheuermittel oder chemische Reinigungsmittel.
 - Zum Reinigen mit einem feuchten Schwamm und warmem Seifenwasser abwischen. Verwenden Sie keine lösungsmittelhaltigen Reiniger oder Reinigungsmittel, da diese das Produkt bleichen oder beschädigen können.

ESPAÑOL - INSTRUCCIONES DE MONTAJE IMPORTANTE - LEER CUIDADOSAMENTE - CONSERVAR ESTAS INSTRUCCIONES PARA FUTURAS CONSULTAS INFORMACIÓN

- Este producto está diseñado para contener 60 kg en total. No exceda este peso.
- Recomendamos que esta unidad se ensamble en la habitación prevista para su uso.
- Cuando esté listo para comenzar, asegúrese de tener las herramientas adecuadas, mucho espacio y un área limpia y seca para el montaje.
- Desenvuelva todos los materiales de embalaje y coloque cada componente encima de la caja de cartón o sobre un suelo limpio para evitar que se raye.
- Verifique el paquete y asegúrese de tener todas las piezas enumeradas.
- Asegúrese de que este producto esté completamente ensamblado como se ilustra antes de usarlo.
- Verifique que todos los tornillos o pernos estén apretados e inspeccione periódicamente.
- Las herramientas no están incluidas a menos que se especifique en la lista de piezas.

ADVERTENCIAS

- Este producto solo debe usarse en un piso firme y nivelado.
 - Mantenga las piezas pequeñas fuera del alcance de los niños.
 - Asegúrese de que las patas/base permanezcan en contacto con el piso.
 - NO utilice herramientas eléctricas para construir este producto.
 - NO ajuste los tornillos hasta que las piezas estén ensambladas o como se recomienda en esta guía.
 - NO apriete demasiado los tornillos o pernos.
 - NO utilice este producto si faltan piezas, están dañadas o desgastadas.
 - NO se suba, se siente ni se pare sobre el producto.
 - El producto debe llenarse con las correas de pared provistas para evitar accidentes y posibles lesiones fatales si el artículo se cae o vuelca durante el uso.
 - Si se suministran fijaciones de pared, asegúrese siempre de que el área de la pared a perforar esté libre de cables eléctricos, tuberías de agua y gas. Las fijaciones de pared suministradas son adecuadas para paredes macizas. Para otros tipos de paredes, las fijaciones adecuadas deben obtenerse por separado. En caso de duda, consulte a un comerciante calificado.
- INFORMACIÓN DE CUIDADO**
- Nunca use estropajos, abrasivos o limpiadores químicos.
 - Para limpiar, pase una esponja húmeda y agua jabonosa tibia. No use limpiadores o detergentes a base de solventes, ya que pueden blanquear o dañar el producto.

NEDERLANDS - MONTAGE-INSTRUCTIES BELANGRIJK - ZORGVULDIG LEZEN - BEWAAR DEZE INSTRUCTIES VOOR TOEKOMSTIGE REFERENTIE INFORMATIE

- Dit product is ontworpen om in totaal 60 kg te dragen. Overschrijd dit gewicht niet.
- We raden aan om dit apparaat te monteren in de ruimte die bedoeld is voor gebruik.
- Als u klaar bent om te beginnen, zorg dan voor het juiste gereedschap, voldoende ruimte en een schone, droge montageplaats.
- Pak al het verpakkingsmateriaal uit en plaats elk onderdeel op de kartonnen doos of op een schone vloer om krassen te voorkomen.
- Controleer de verpakking en zorg ervoor dat u alle vermelde onderdelen hebt.
- Zorg ervoor dat dit product vóór gebruik volledig is gemonteerd zoals afgebeeld.
- Controleer of alle schroeven of bouten zijn aangedraaid en inspecteer deze regelmatig.
- Gereedschap is niet inbegrepen, tenzij gespecificeerd in de onderdelenlijst.

WAARSCHUWINGEN

- Dit product mag alleen worden gebruikt op een stevige en vlakke vloer.
 - Houd kleine onderdelen buiten het bereik van kinderen.
 - Zorg ervoor dat de poten/voet in contact blijven met de vloer.
 - Gebruik GEEN elektrisch gereedschap om dit product te bouwen.
 - Draai de schroeven NIET vast voordat de onderdelen zijn gemonteerd of zoals geadviseerd in deze handleiding.
 - Draai schroeven of bouten NIET te vast aan.
 - Gebruik dit product NIET als er onderdelen ontbreken, beschadigd of versleten zijn.
 - Klim, zit of sta NIET op het product.
 - Het product moet worden gevuld met behulp van meegeleverde muurriemen om ongelukken en mogelijk dodelijk letsel te voorkomen als het item tijdens het gebruik valt of omvalt.
 - Als er muurbevestigingen worden meegeleverd, zorg er dan altijd voor dat het te boren muuropervlak vrij is van elektrische draden, water- en gasleidingen. De meegeleverde wandbevestiging is geschikt voor massieve wanden. Voor andere wandtypes dienen geschikte bevestigingen apart te worden aangeschaft. Raadpleeg bij twijfel een gekwalificeerde vakman.
- VERZORGINGSINFORMATIE**
- Gebruik nooit schuursponsjes, schuurmiddelen of chemische reinigingsmiddelen.
 - Om schoon te maken, afvegen met een vochtige spons en warm zeepsop. Gebruik geen reinigingsmiddelen of reinigingsmiddelen op basis van oplosmiddelen, omdat deze het product kunnen bleken of beschadigen.

ITALIANO - ISTRUZIONI DI MONTAGGIO IMPORTANTE - LEGGERE ATTENTAMENTE - CONSERVARE QUESTE ISTRUZIONI PER FUTURI RIFERIMENTI INFORMAZIONE

- Questo prodotto è progettato per contenere 60 kg in totale. Non superare questo peso.
 - Si consiglia di assemblare questa unità nella stanza destinata all'uso.
 - Quando sei pronto per iniziare, assicurati di avere gli strumenti giusti, molto spazio e un'area pulita e asciutta per il montaggio.
 - Scartare tutti i materiali di imballaggio e posizionare ogni componente sopra la scatola di cartone o su un pavimento pulito per evitare che si graffi.
 - Controllare la confezione e assicurarsi di avere tutte le parti elencate.
 - Assicurarsi che questo prodotto sia completamente assemblato come illustrato prima dell'uso.
 - Controllare che tutte le viti o bulloni siano serrati e ispezionarli regolarmente.
 - Gli strumenti non sono inclusi se non specificato nell'elenco delle parti.
- AVVERTENZE**
- Questo prodotto deve essere utilizzato solo su un pavimento solido e piano.
 - Tenere le parti piccole fuori dalla portata dei bambini.
 - Assicurarsi che le gambe/base rimangano a contatto con il pavimento.
 - NON utilizzare utensili elettrici per costruire questo prodotto.
 - NON serrare le viti fino a quando le parti non sono state assemblate o come consigliato in questa guida.
 - NON serrare eccessivamente viti o bulloni.
 - NON utilizzare questo prodotto se le parti sono mancanti, danneggiate o usurate.
 - NON arrampicarsi, sedersi o stare in piedi sul prodotto.
 - Il riempimento del prodotto deve essere effettuato utilizzando le cinghie a muro fornite per evitare incidenti e possibili lesioni mortali in caso di caduta o ribaltamento dell'oggetto durante l'uso.
 - Se vengono forniti fissaggi a parete, assicurarsi sempre che l'area della parete da forare sia priva di cavi elettrici, tubi dell'acqua e del gas. I fissaggi in dotazione sono adatti per pareti solide. Per altri tipi di parete, gli opportuni fissaggi devono essere ottenuti separatamente. In caso di dubbio, consultare un professionista qualificato.
- INFORMAZIONI PER LA CURA**
- Non utilizzare mai pagliette, abrasivi o detergenti chimici.
 - Per pulire, strofinare con una spugna umida e acqua tiepida e sapone. Non utilizzare detersivi o detersivi a base di solventi in quanto possono sbiancare o danneggiare il prodotto.

SVENSKA - MONTERINGSINSTRUKTIONER
VIKTIGT - LÄS NOGGRANT - BEHÅLL DESSA INSTRUKTIONER
FÖR FRAMTIDA REFERENS
INFORMATION

- Denna produkt är designad för att hålla 60 kg totalt. Överskrid inte denna vikt.
- Vi rekommenderar att denna enhet monteras i det rum som är avsett för användning.
- När du är redo att börja, se till att du har rätt verktyg, gott om plats och en ren, torr plats för montering.
- Packa upp allt förpackningsmaterial och placera varje komponent ovanpå kartongen eller på ett rent golv för att förhindra att den repas.
- Kontrollera förpackningen och se till att du har alla listade delar.
- Se till att denna produkt är helt monterad enligt bilden före användning.
- Kontrollera att alla skruvar eller bultar är åtdragna och inspektera regelbundet.
- Verktyg ingår inte om det inte anges i reservdelslistan.

VARNINGAR

- Denna produkt bör endast användas på ett fast och plant golv.
- Förvara små delar utom räckhåll för barn.
- Se till att benen/basen förblir i kontakt med golvet.
- ANVÄND INTE elverktyg för att tillverka denna produkt.
- Dra INTE åt skruvarna förrän delarna är monterade eller enligt anvisningarna i denna guide.
- Dra INTE åt skruvar eller bultar för hårt.
- ANVÄND INTE denna produkt om delar saknas, är skadade eller slitna.
- Klättra, sitt eller stå INTE på produkten.
- Produkten måste fyllas med hjälp av medföljande väggremmar för att undvika olyckor och eventuella dödliga skador om föremålet välter eller välter under användning.
- Om väggfästen medföljer, se alltid till att väggområdet som ska borras är fritt från elektriska ledningar, vatten- och gasrör. Det medföljande väggfästet är lämpligt för massiva väggar. För andra typer av väggar måste lämpliga fästen erhållas separat. Om du är osäker, kontakta en kvalificerad hantverkare.

VÅRDINFORMATION

- Använd aldrig skurmedel, slipmedel eller kemiska rengöringsmedel.
- För att rengöra, torka av med en fuktig svamp och varmt . . tvålwaterAnvänd inte lösningsmedelsbaserade rengöringsmedel eller rengöringsmedel eftersom de kan bleka eller skada produkten.

POLSKA - INSTRUKCJA MONTA U
WA NE – PRZECZYTAJ UWA NIE – ZACHOWAJ TE
INSTRUKCJE DO WYKORZYSTANIA W PRZYSZŁO CI
INFORMACJA

- Ten produkt został zaprojektowany, aby pomie ci ł cznie 60 kg. Nie przekraczaj tej wagi.
- Zalecamy, aby urz dzenie było montowane w pomieszczeniu przeznaczonym do u ytku.
- Kiedy b dziesz gotowy do rozpocz cia, upewnij si , e masz odpowiednie narz dzia, du o miejsca i czyste, suche miejsce do monta u.
- Rozwi wszystkie materiały opakowaniowe i umie ka dy element na wierzchu kartonu lub na czystej podłodze, aby zapobiec zarysowaniu.
- Sprawdź opakowanie i upewnij si , e masz wszystkie wymienione cz ci.
- Przed u yciem upewnij si , e produkt jest w pełni zmontowany,

jak pokazano na ilustracji.

- Sprawdź , czy wszystkie ruby lub ruby s dokr cone i regularnie sprawdzaj.
- Narz dzia nie s uwzgl dniane, chyba e okre lono je na li cie cz ci.

OSTRZE ENIA

- Ten produkt powinien by u ywany tylko na twardej i równej podłodze.
- Przechowuj małe cz ci poza zasi giem dzieci.
- Upewnij si , e nogi/podstawa pozostaj w kontakcie z podłog .
- NIE NALE Y u ywa elektronarz dzi do budowy tego produktu.
- NIE WOLNO dokr ca rub, dopóki cz ci nie zostan zmontowane lub zgodnie z zaleceniami zawartymi w tym przewodniku.
- NIE WOLNO nadmiernie dokr ca rub ani rub.
- NIE u ywaj tego produktu, je li brakuje cz ci, s one uszkodzone lub zu yte.
- NIE WOLNO wspina si , siada ani stawa na produkcie.
- Produkt nale y napełnia za pomoc dostarczonych ta m ciennych, aby unikn wypadków i mo liwych miertelnych obra e , je li przedmiot przewróci si lub przewróci podczas u ytkowania.
- Je li dostarczane s mocowania cienne, nale y zawsze upewni si , e wiercony obszar ciany jest wolny od przewodów elektrycznych, rur wodoci gowych i gazowych. Dostarczone mocowanie cienne nadaje si do cian litych. W przypadku innych rodzajów cian odpowiednie mocowania nale y zakupi osobno. W razie w tpiwo ci skonsultuj si z wykwalifikowanym handlowcem.

INFORMACJE DOTYCZ CE OPIEKI

- Nigdy nie u ywaj druciaków, materiałów ciennych ani chemicznych rodków czyszcz cych.
- Do czyszczenia przetrzyj wilgotn g bk i ciepł wod z . mydłemNie u ywaj rodków czyszcz cych ani detergentów na bazie rozpuszczalników, poniewa mog one wybieli lub uszkodzi produkt.

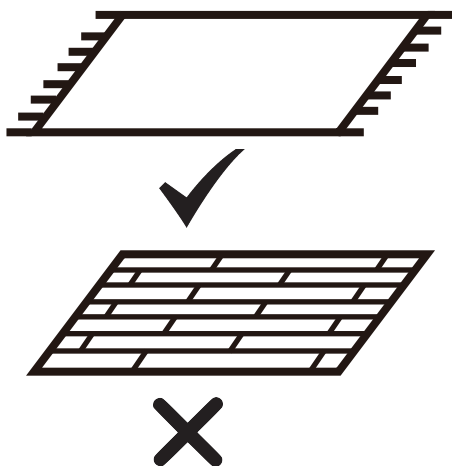

NEED HELP?



CONTACT

www.xrockeruk.com/pages/support

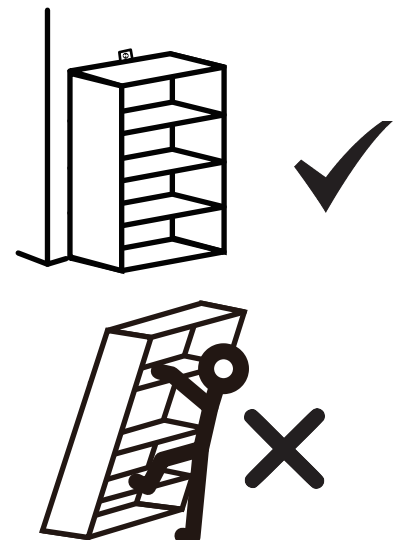

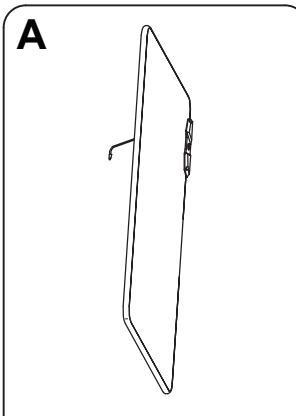

Description:Top Panel
Qty:1

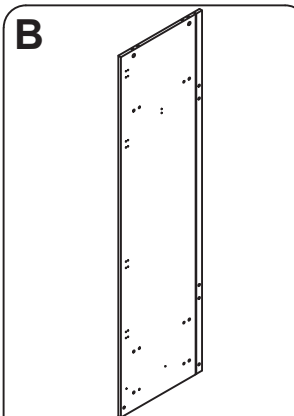

Description:Left Side Panel
Qty:1

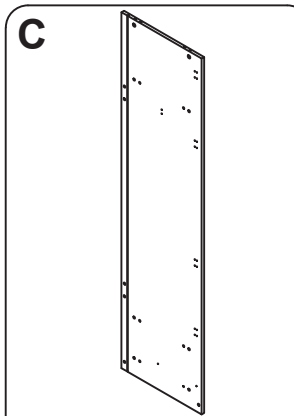

Description:Right Side Panel
Qty:1

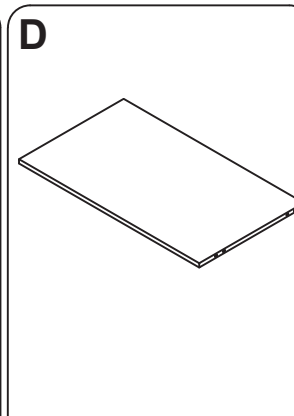

Description:Top Shelf Panel
Qty:1

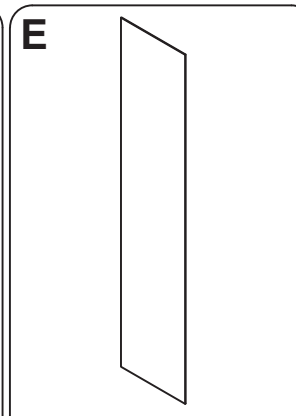

Description:Back Panel
Qty:2

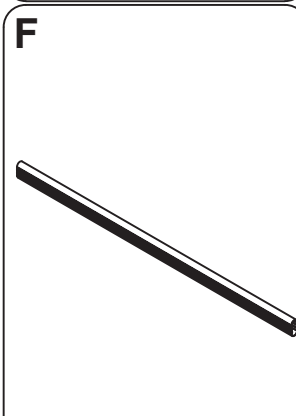

Description:Hanging Rail
Qty:1

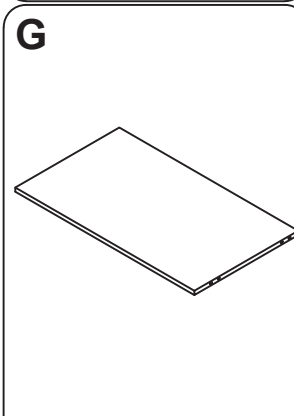

Description:Middle Shelf Panel
Qty:1

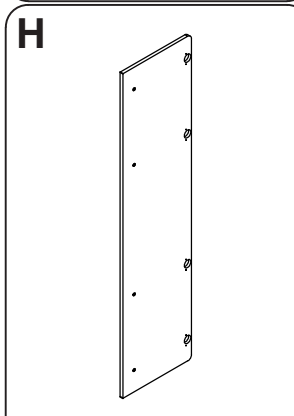

Description:Left Door Panel
Qty:1

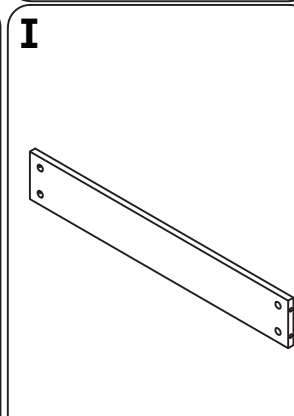

Description:Back Support
Panel
Qty:2

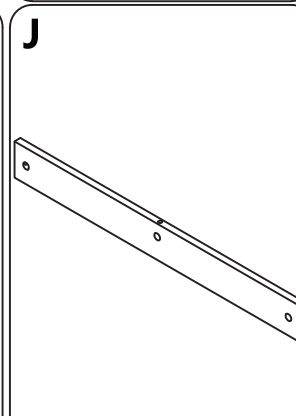

Description:Bottom Support
Panel
Qty:2

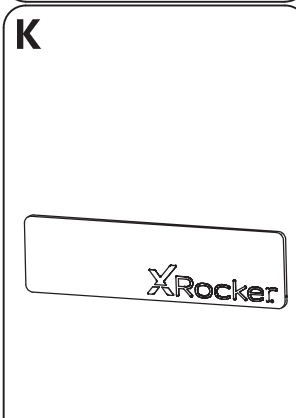

Description:Drawer Panel
Qty:1

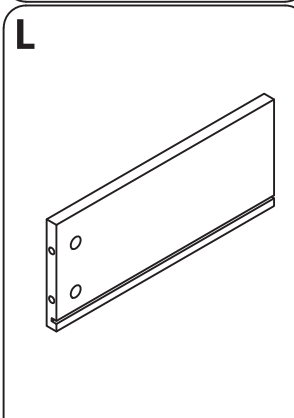

Description:Drawer Left Panel
Qty:1

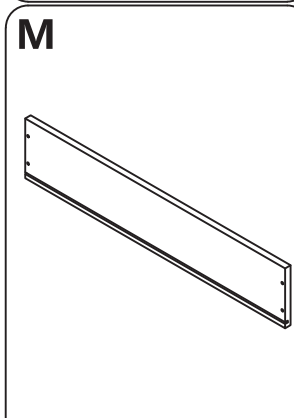

Description:Drawer Back Panel
Qty:1

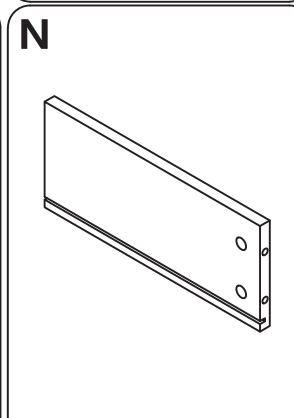

Description:Drawer Right Panel
Qty:1

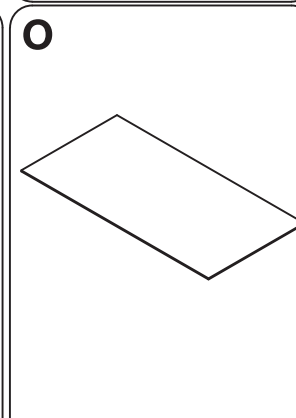

Description:Drawer Bottom
Panel
Qty:1

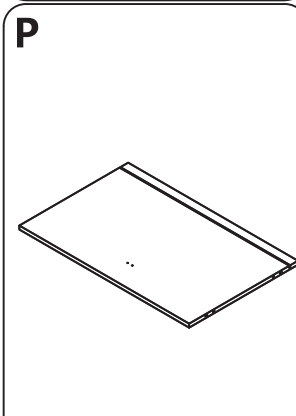

Description:Bottom Panel
Qty:1

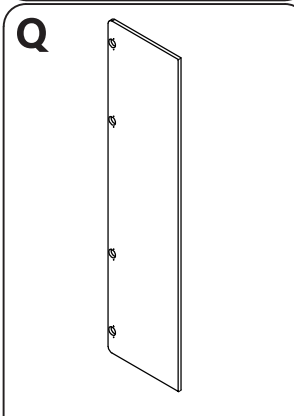

Description:Right Door Panel
Qty:1

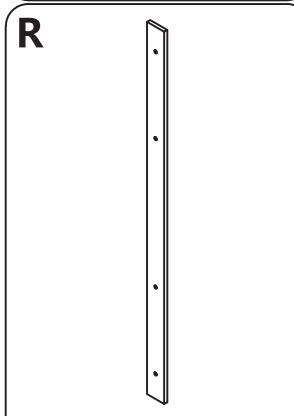

Description:Left Door Back
Panel
Qty:1

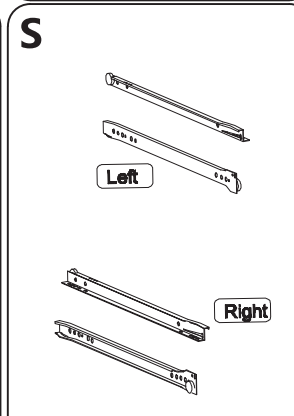

X 1 SET

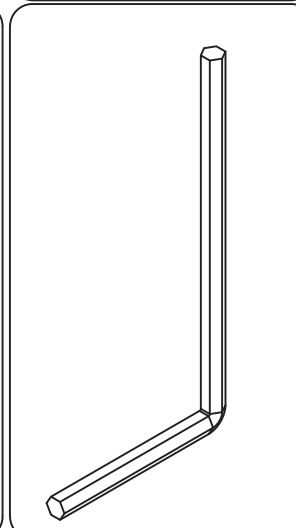

Fittings (to scale)

Code	Item	Quantity
①	Cam Bolt (Ø6x35mm)	34
②	Cam Lock (Ø15x10mm)	34
③	Wood Dowel (Ø6x40mm)	16
④	Screw (Ø4x35mm)	4
⑤	Screw (Ø4x12mm)	74
⑥	Screw (Ø6x15mm)	4

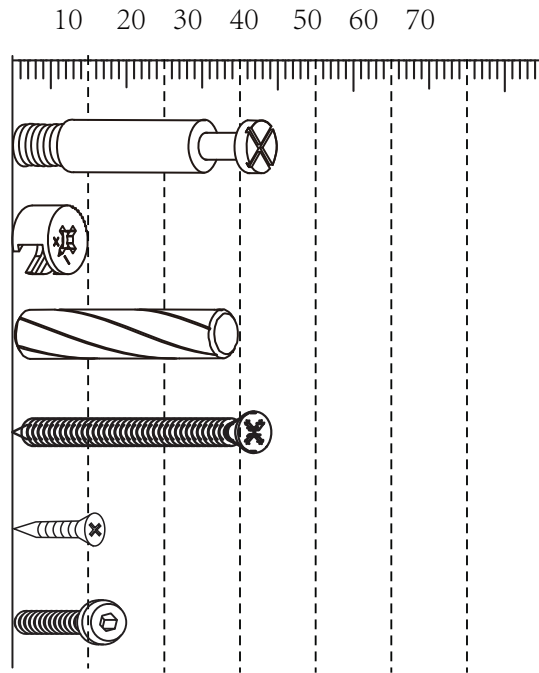

Not to scale)

⑦	Adhesive tape	2	
⑧	Wall Fixings Hardware Set	2	
⑨	Plastic Bracket	12	
⑩	Door Hinges	8	
⑪	Hanging Rail Support	2	
⑫	Remote Control	1	
⑬	Screwdriver (Not Provided)	1	
⑭	Plastic Drawer Stop	1	

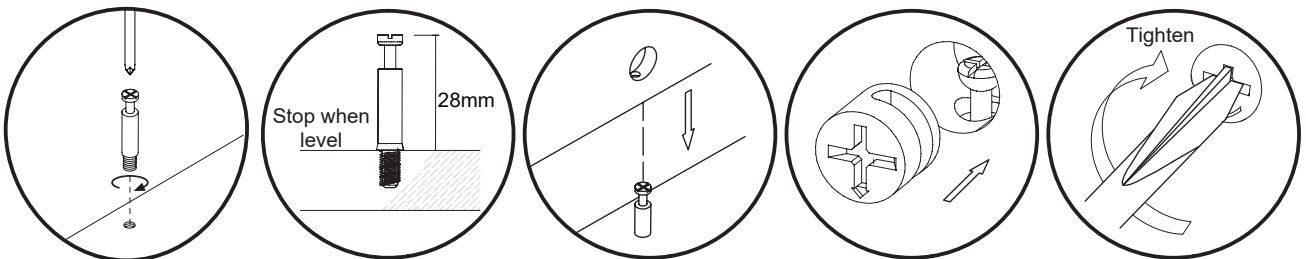

1

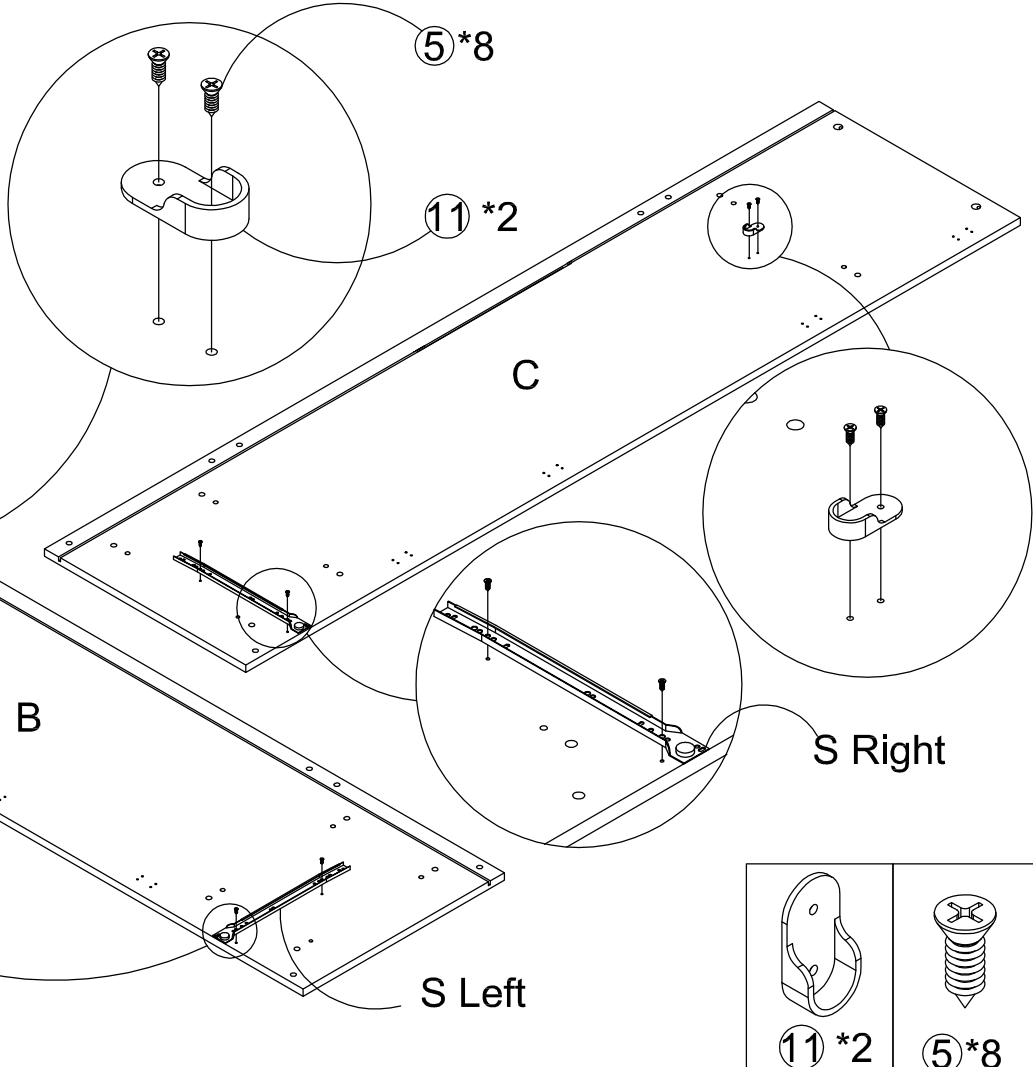
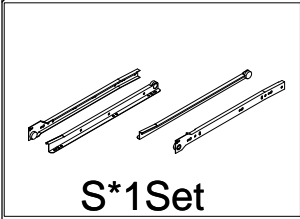

2

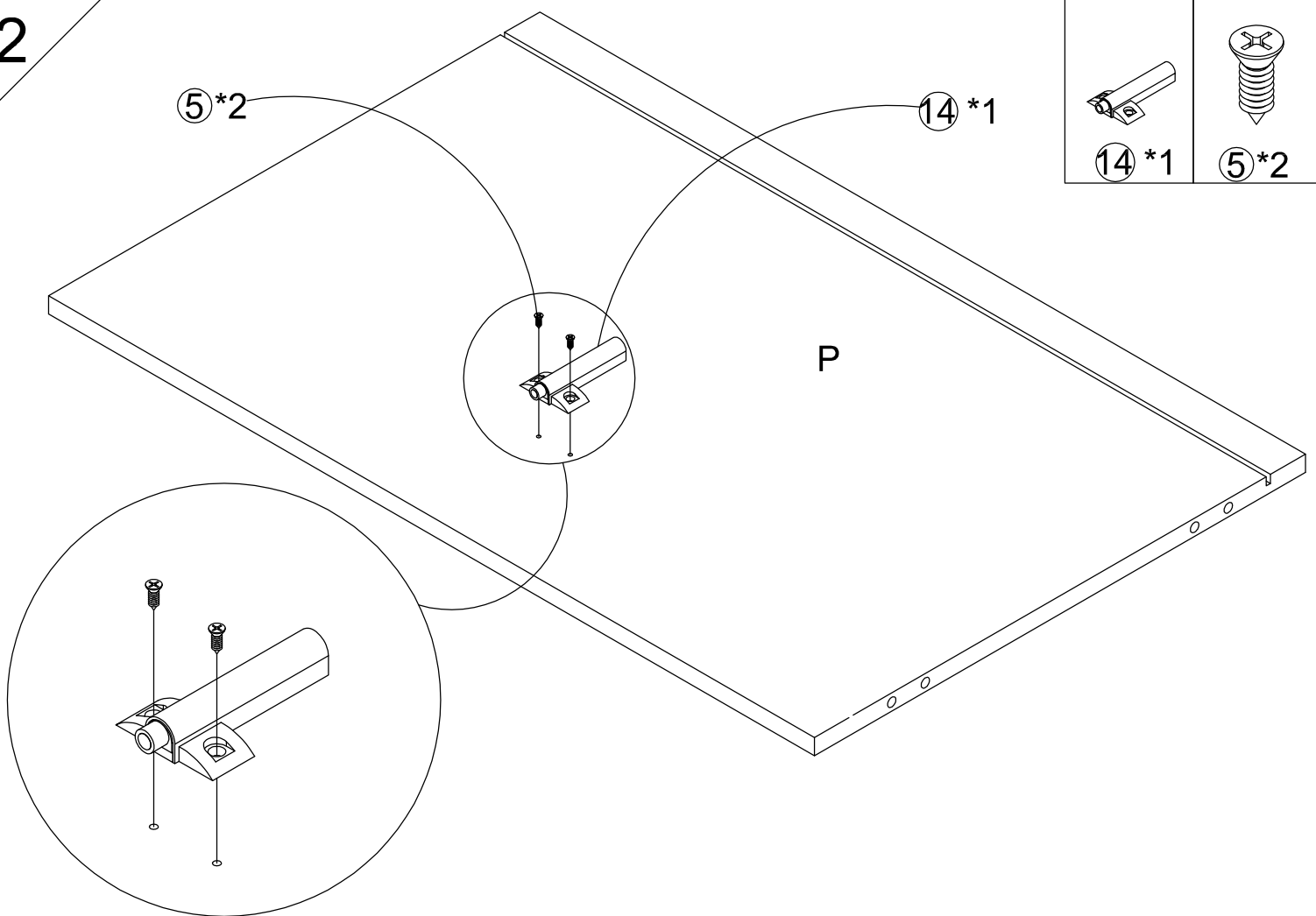

3

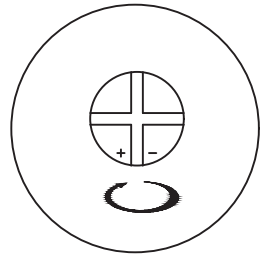
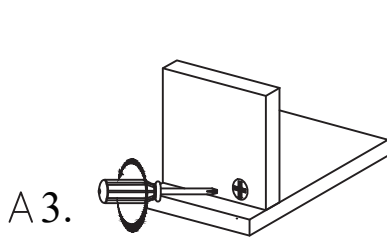
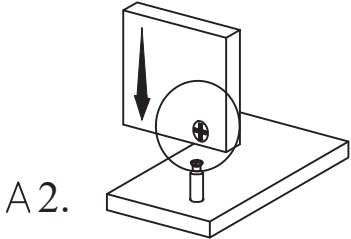
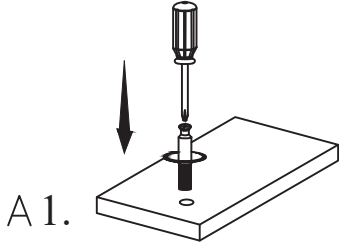
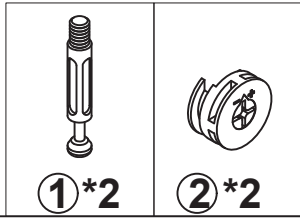
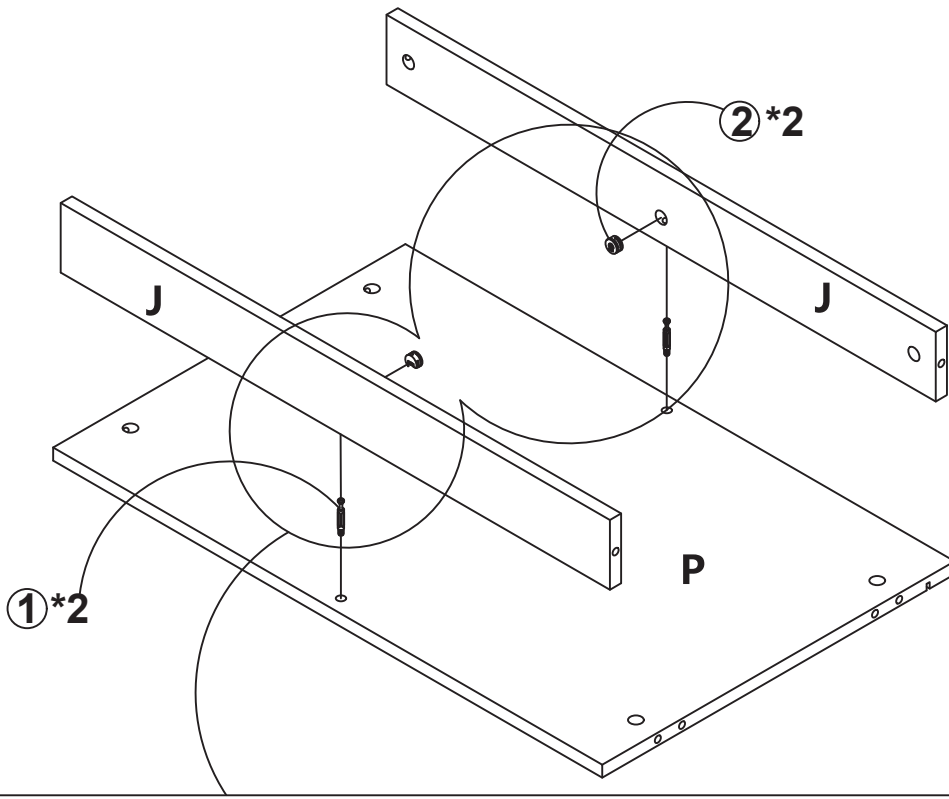

4

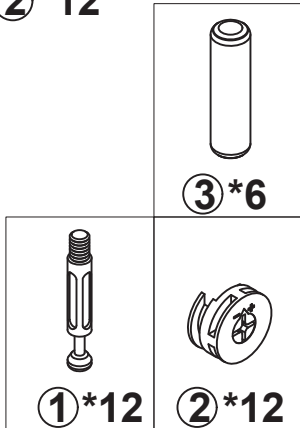
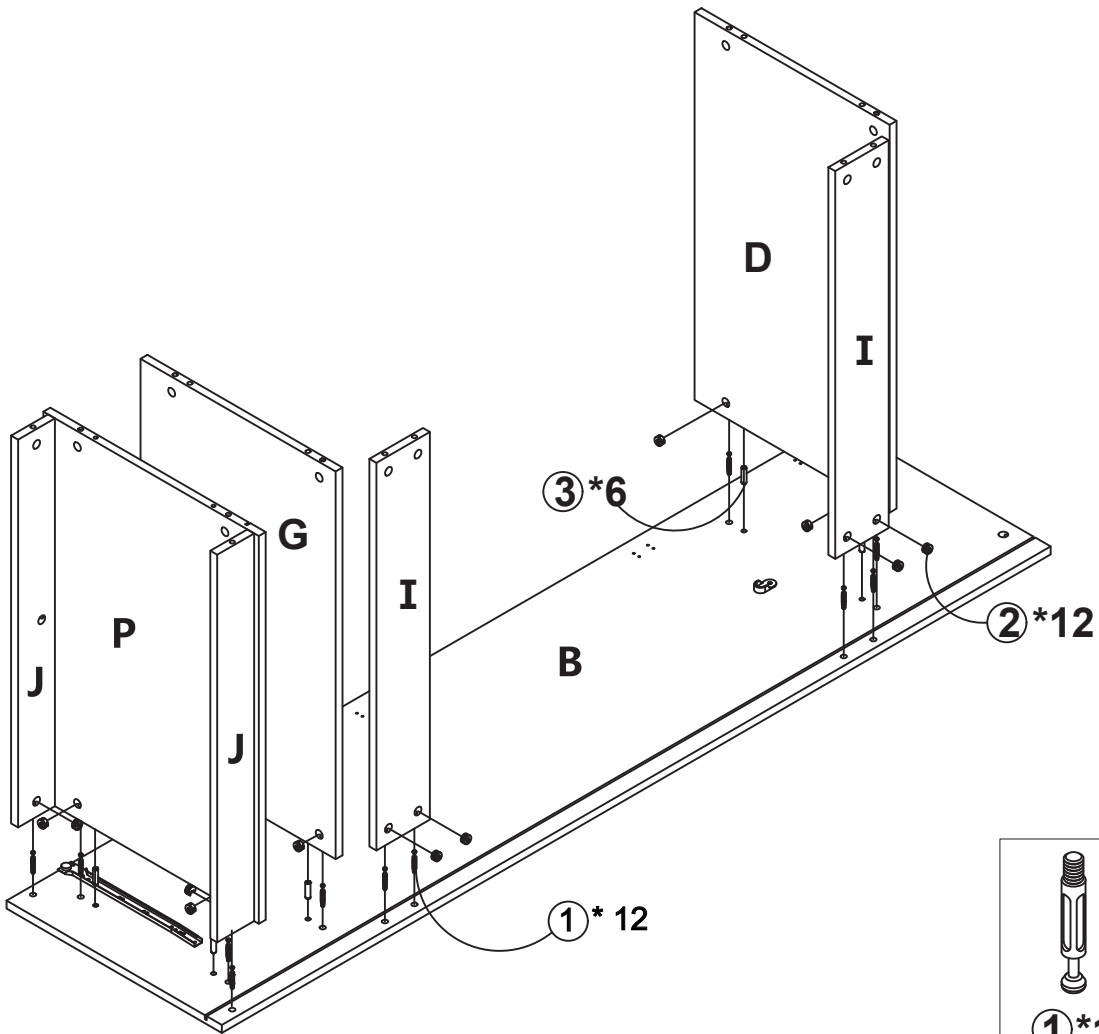

5

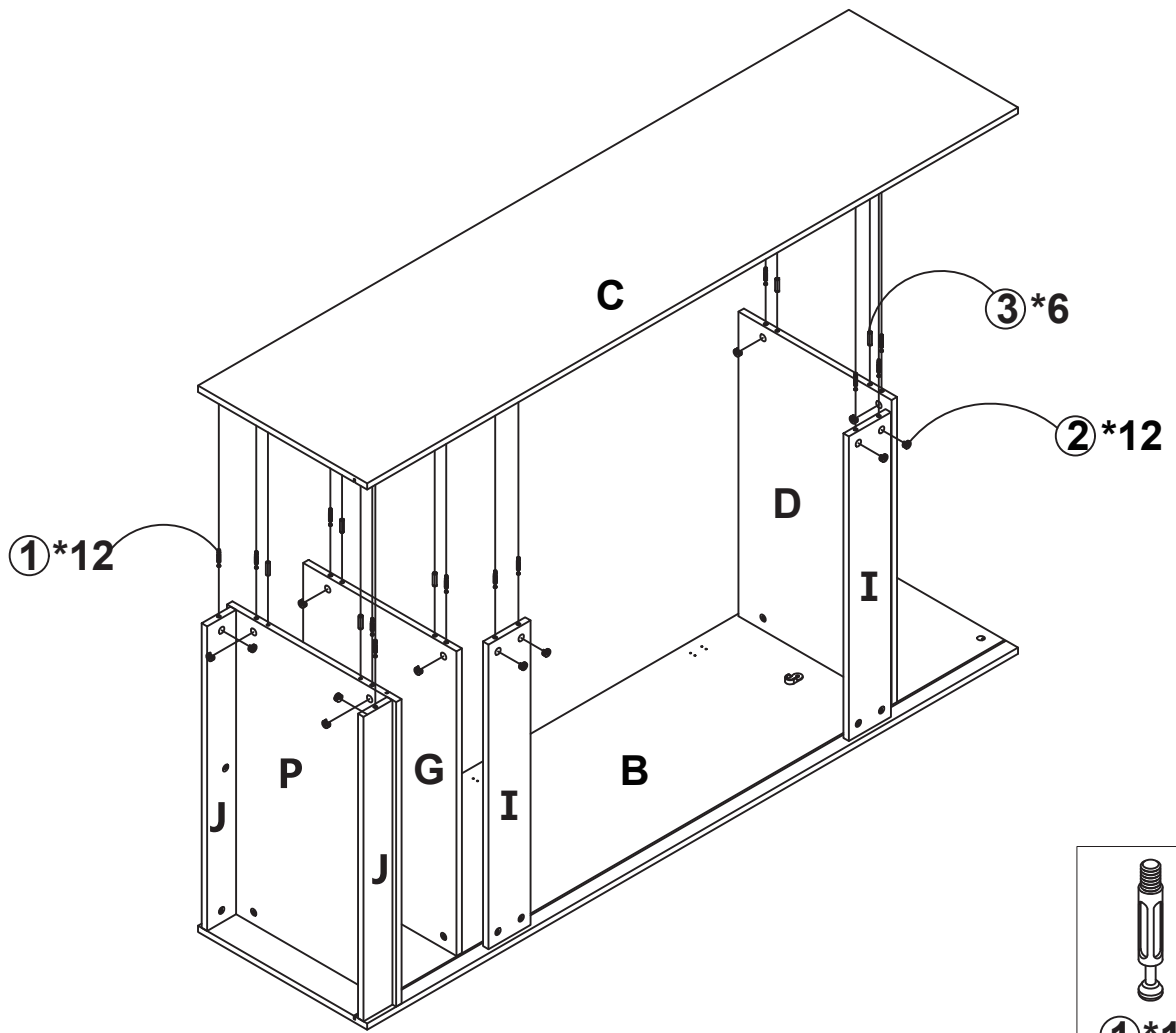

6

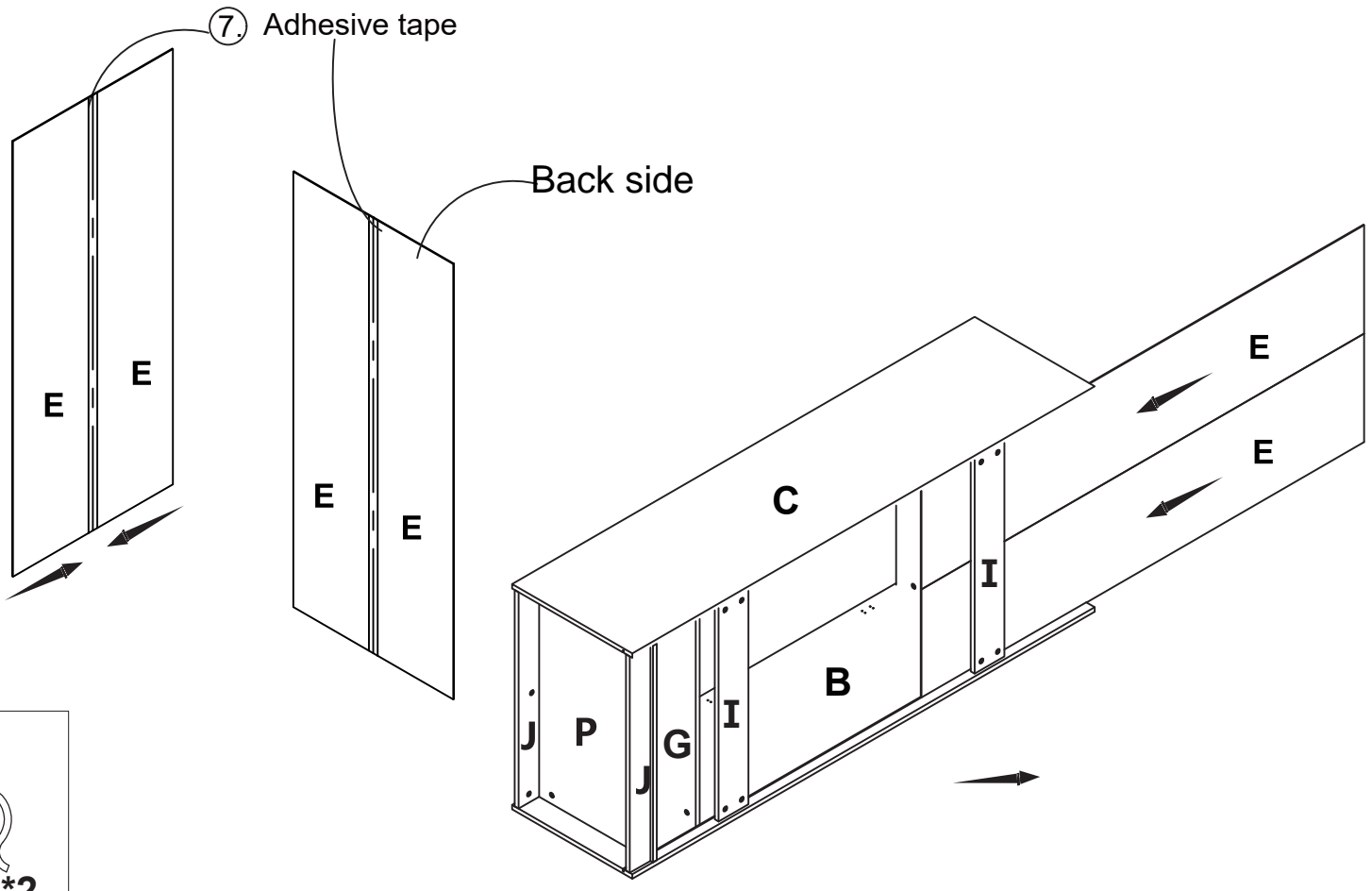

7

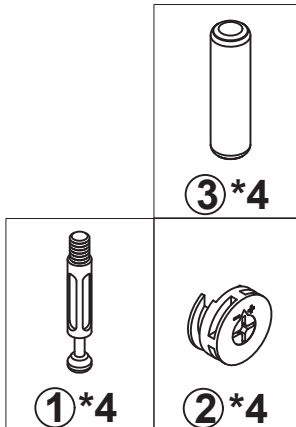
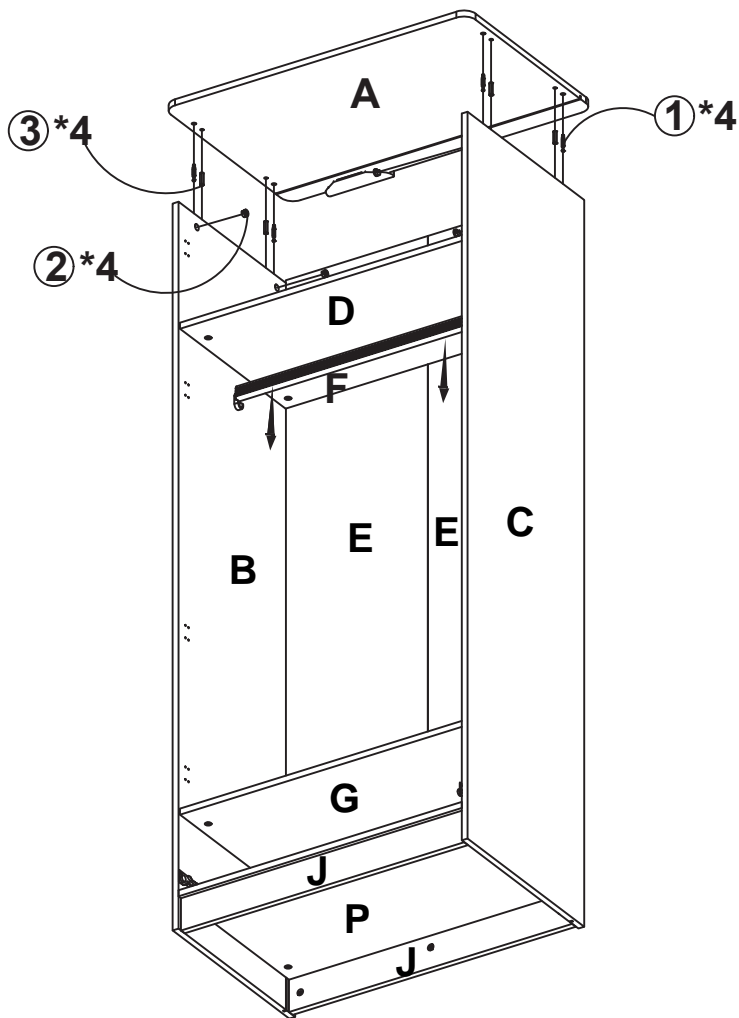

8

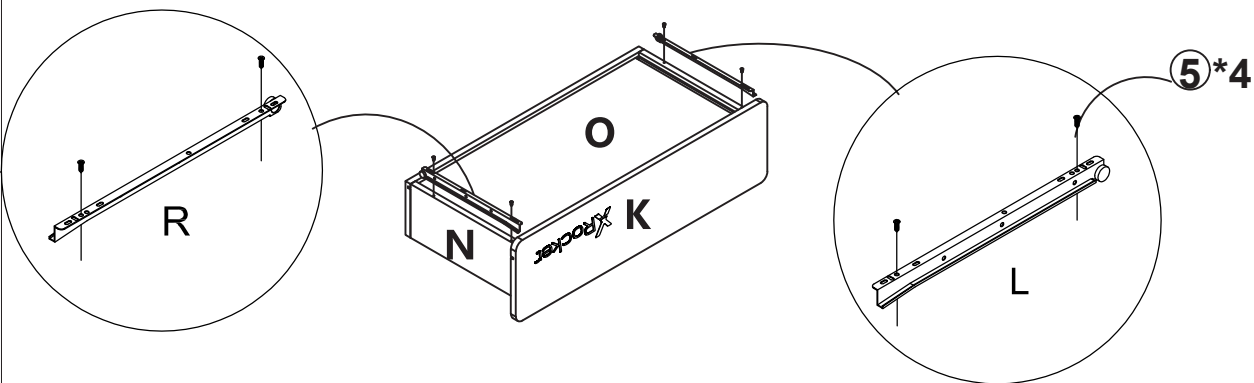
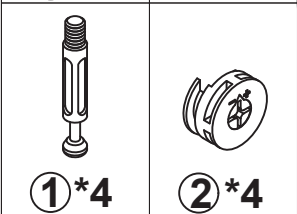
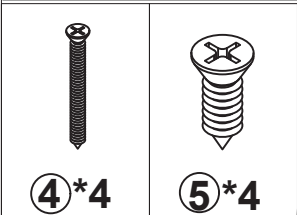
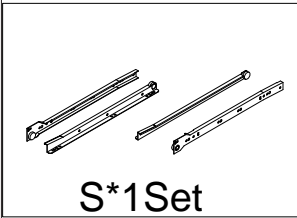
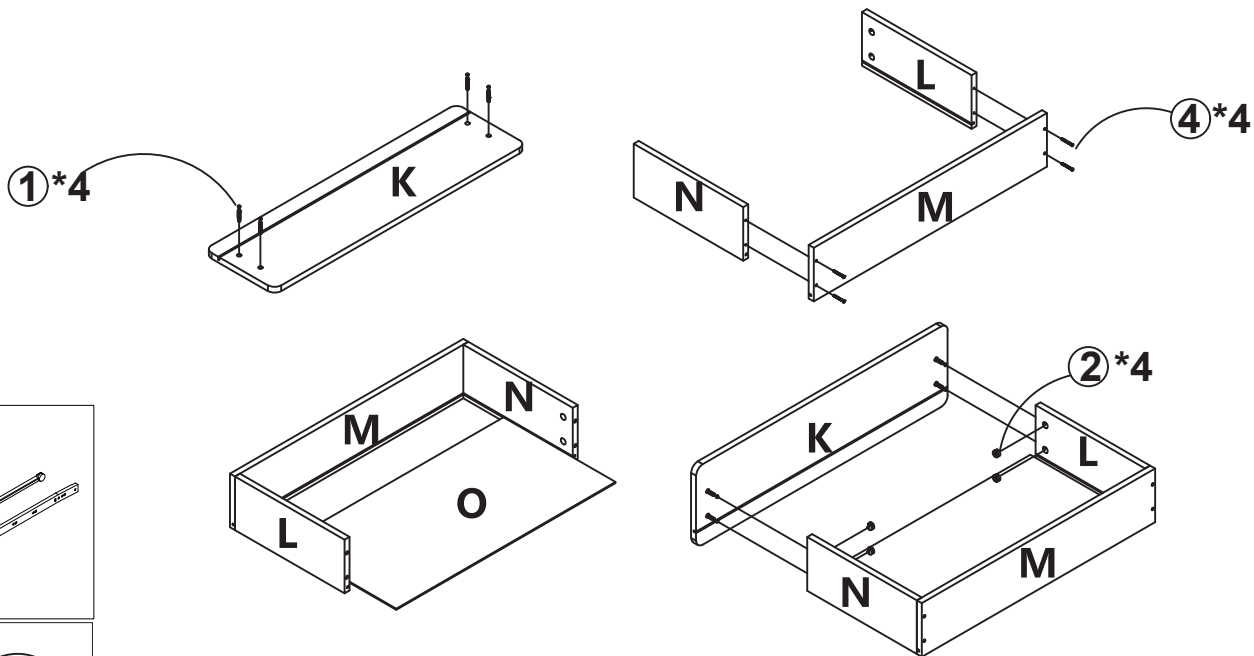

9

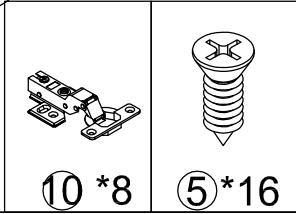
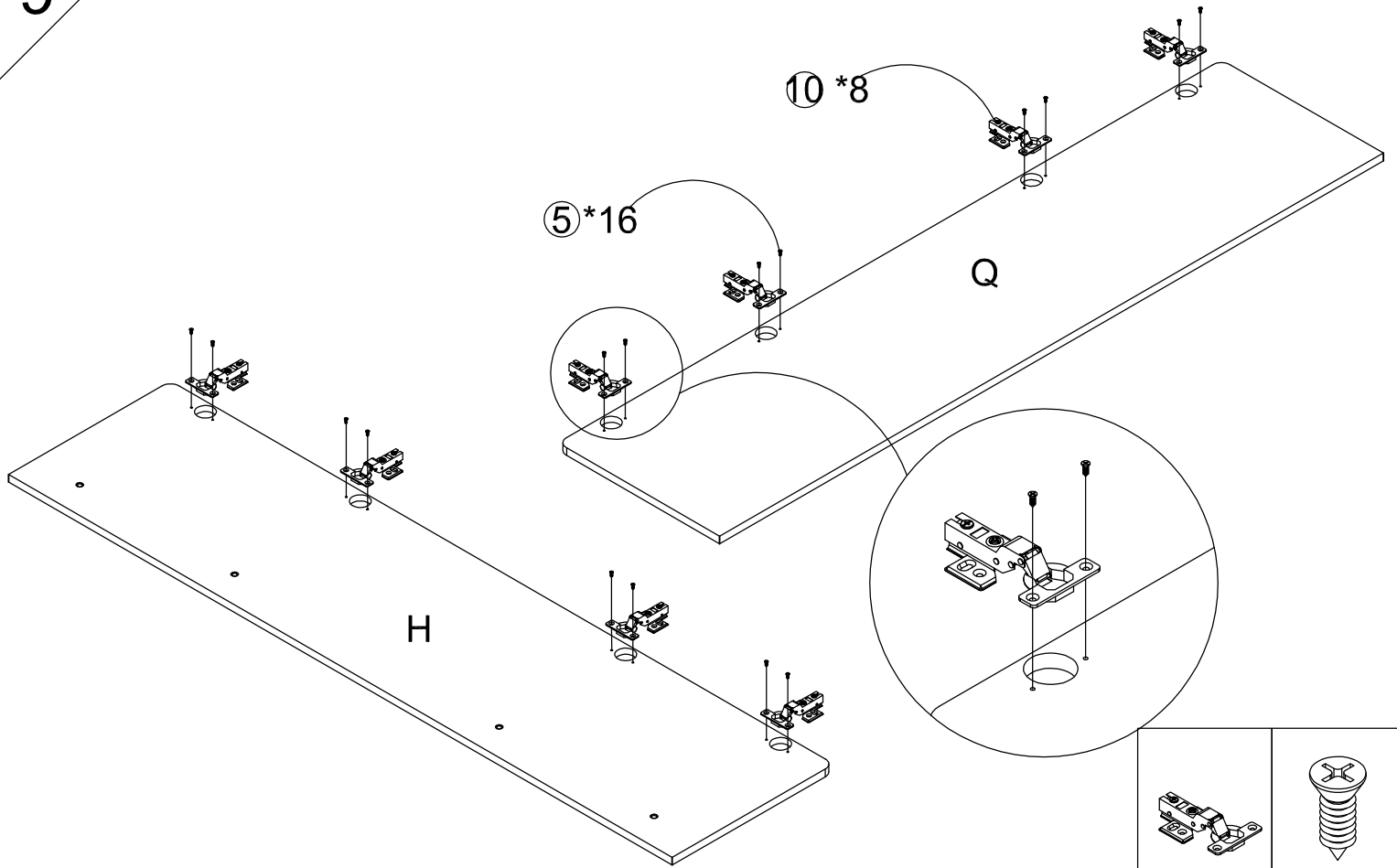

10

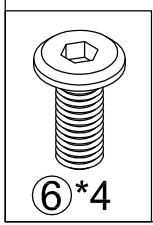
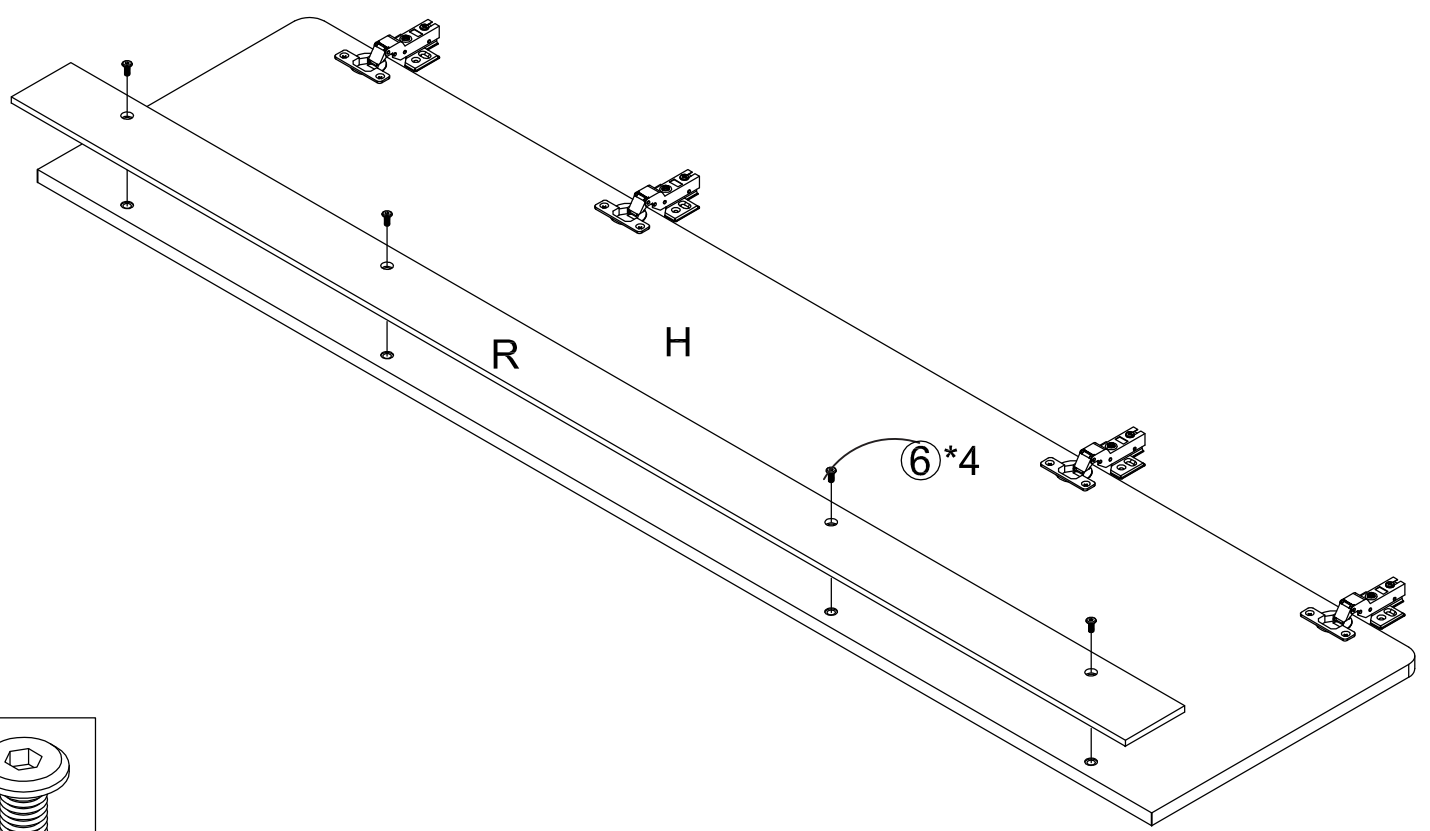

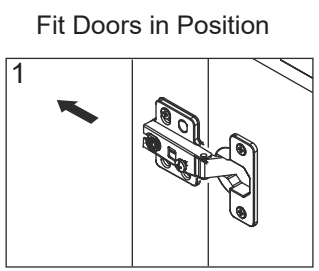
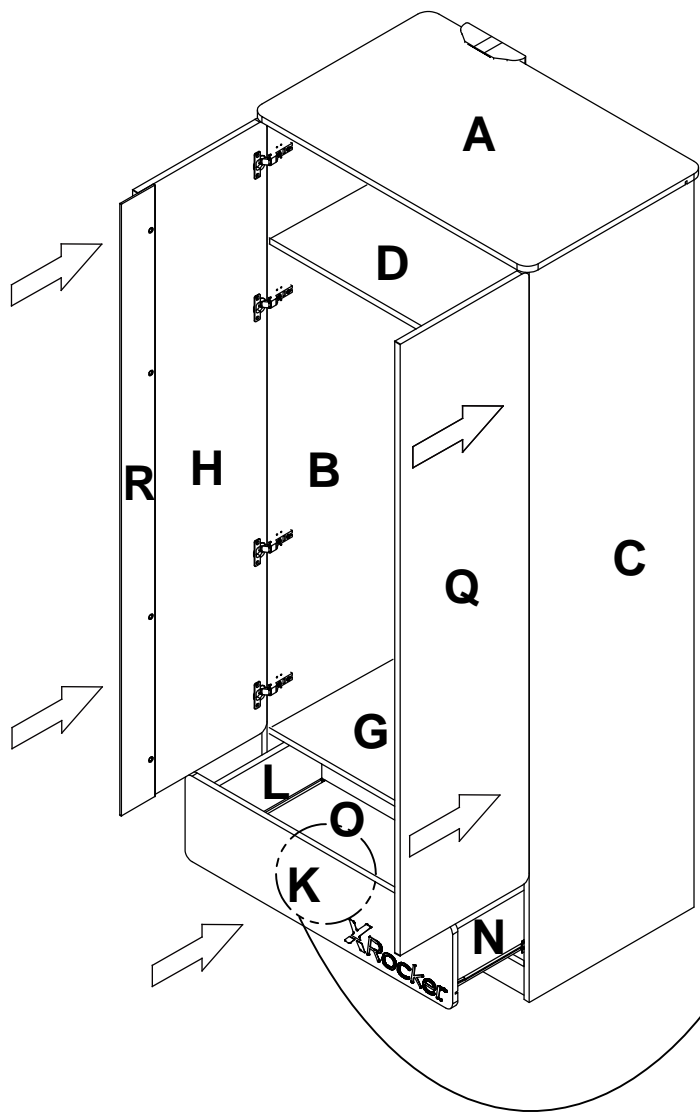

Fittings required

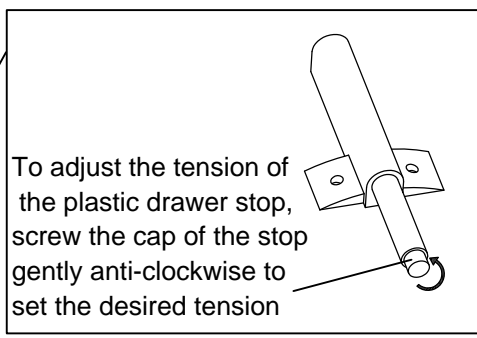
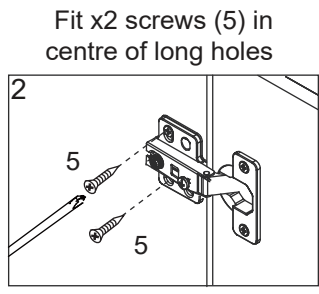

MAKE SURE WARDROBE IS LEVEL
IF DOORS NEED ADJUSTING, CAREFULLY FOLLOW THESE STEPS

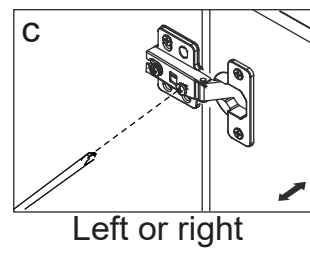
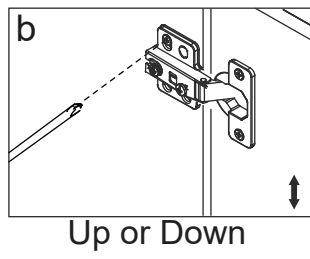
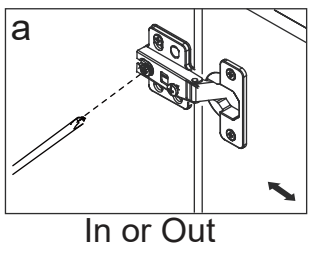

Once both doors are level, (adjusting if necessary as per the steps a, b & c), fix x2 more screws (5) in the round holes, to lock each hinge plate (10) in its final position.

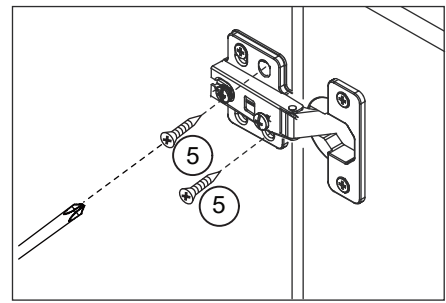

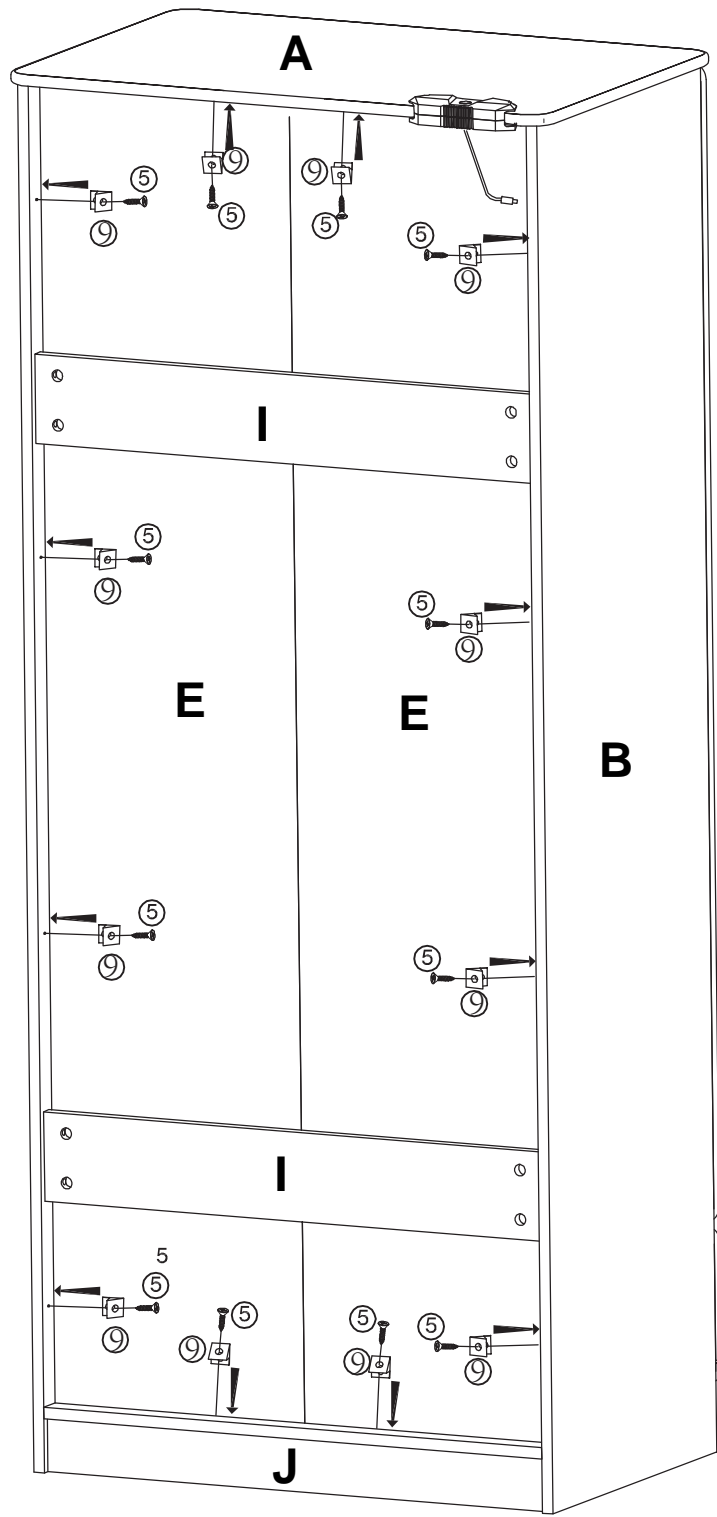
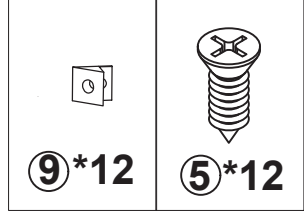

13

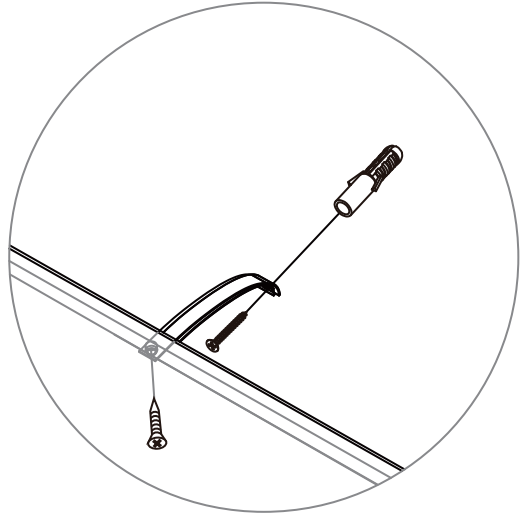
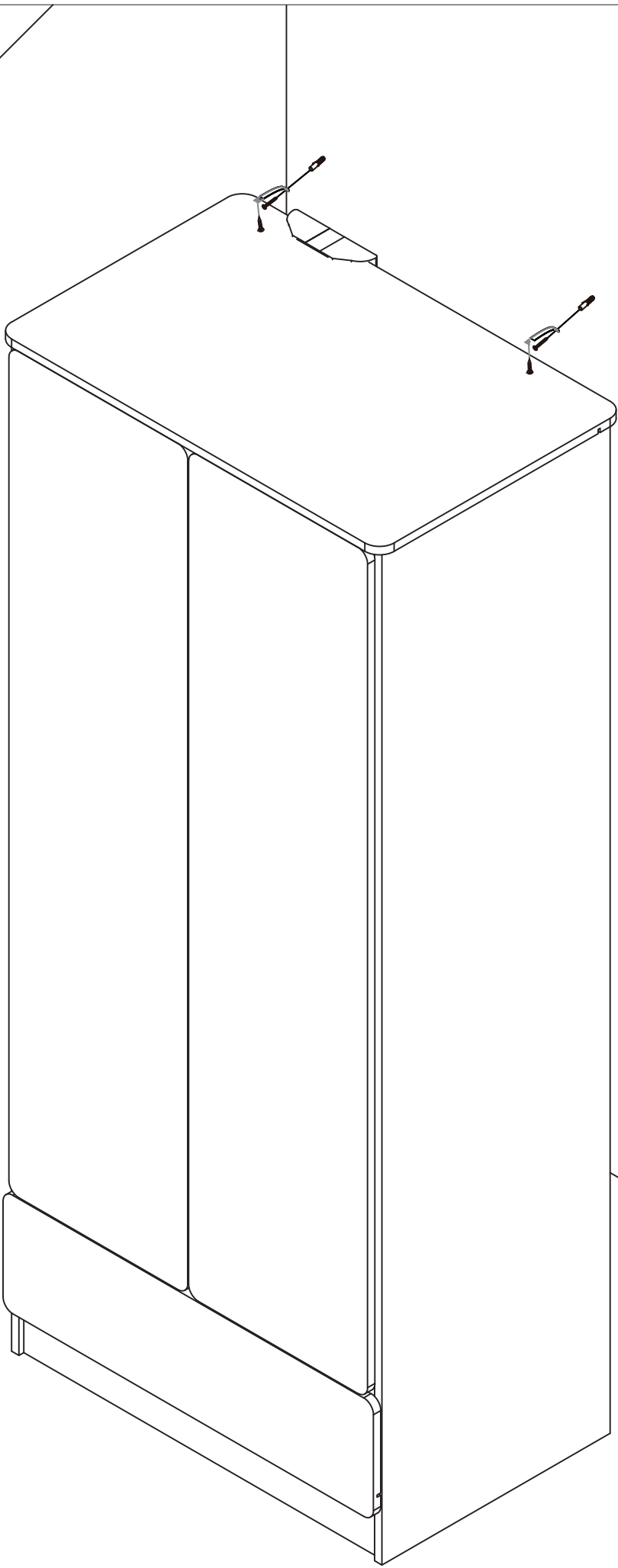

For this step: Tools required

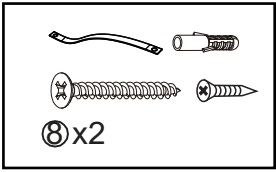
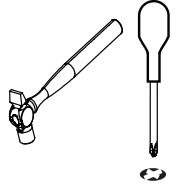

A Guide to Wall Mounting & Fixings

Important note:

If plastic wall plugs are supplied with your product:



- these are only suitable for use in masonry walls.

If you are in any doubt about the correct wall plugs for your wall, seek professional advice.

Failure of the product due to using incorrect fixings is the responsibility of the installer.



Important: When drilling into walls always check that there are no hidden wires or pipes etc.

Make sure that the screws and wall plugs being used are suitable for supporting your unit. Consult a qualified tradesperson if you are unsure.

Hints:

- 1: General rule:  Always use a larger screw and wall plug if you are not sure.
- 2: Ensure you use the recommended drill bit to match the wall plug and hole size.
- 3: Ensure you drill the hole horizontally, do not force the drill or enlarge the hole.
- 4: Take extra care when drilling high walls, ceilings and ceramic tiles. Ensure wall plugs are inserted beyond the thickness of the ceramic tiles to avoid the tiles splitting or cracking.
- 5: Ensure wall plugs are well fitted and are a tight fit in the drilled hole.

ALL HOME FITTINGS ARE PERFORMED AT THE USERS OWN RISK. PLEASE CONSULT PROFESSIONAL ASSISTANCE IF NEEDED.

Types of walls

You can use one of the following types of wall plug if your walls are made of brick, breeze block, concrete, stone or wood.

No.1 "General Purpose" wall plug

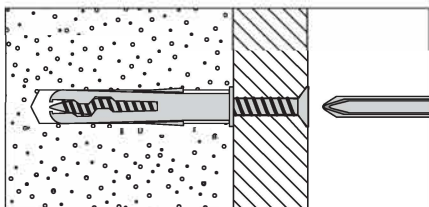

Generally aerated blocks should not be used to support heavy loads, use a specialist fitting in this case. For light loads, general purpose wall plugs can be used.

No.2 "Plasterboard" wall plug

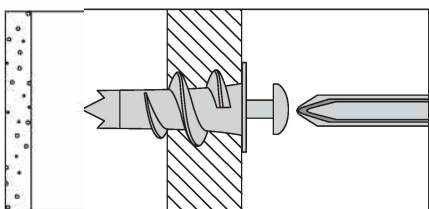

For use when attaching light loads on to plasterboard partitions.

No.3 "Cavity Fixing" wall plug

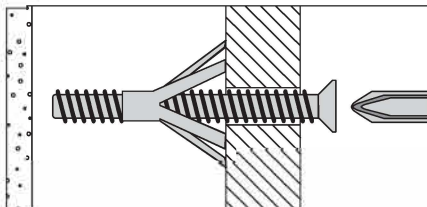

For use with plasterboard partitions or hollow wooden doors.

No.4 "Cavity Fixing-Heavy Duty" wall plug

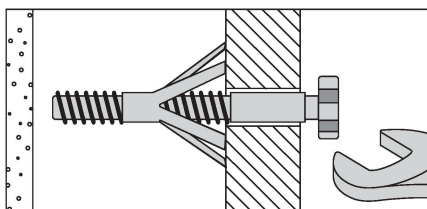

For use when fitting or supporting heavy loads such as shelving, wall cabinets and coat racks.

No.5 "Hammer Fixing" wall plug

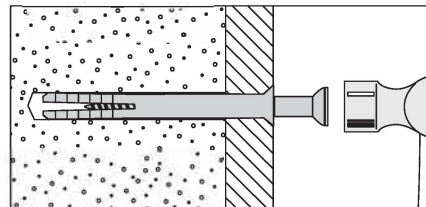

For use with walls stuck with plasterboard. The hammer fixing allows it to be fixed to the wall rather than the plasterboard. Always check the fixing is secure to the retaining wall.

No.6 "Shield Anchor" wall plug Heavy loads

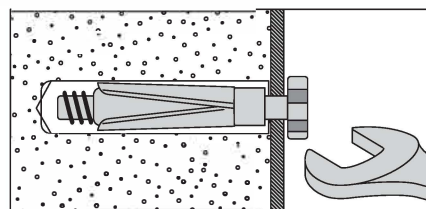

For use with heavier loads such as TV & HiFi speakers and satellite dishes etc.



Care & Maintenance

Safety: Always check the fitting and location to ensure your safety in and around the home.

Fitting: From time to time check the fitting to ensure the wall plugs or screws do not become loose.

Control panel operating instructions

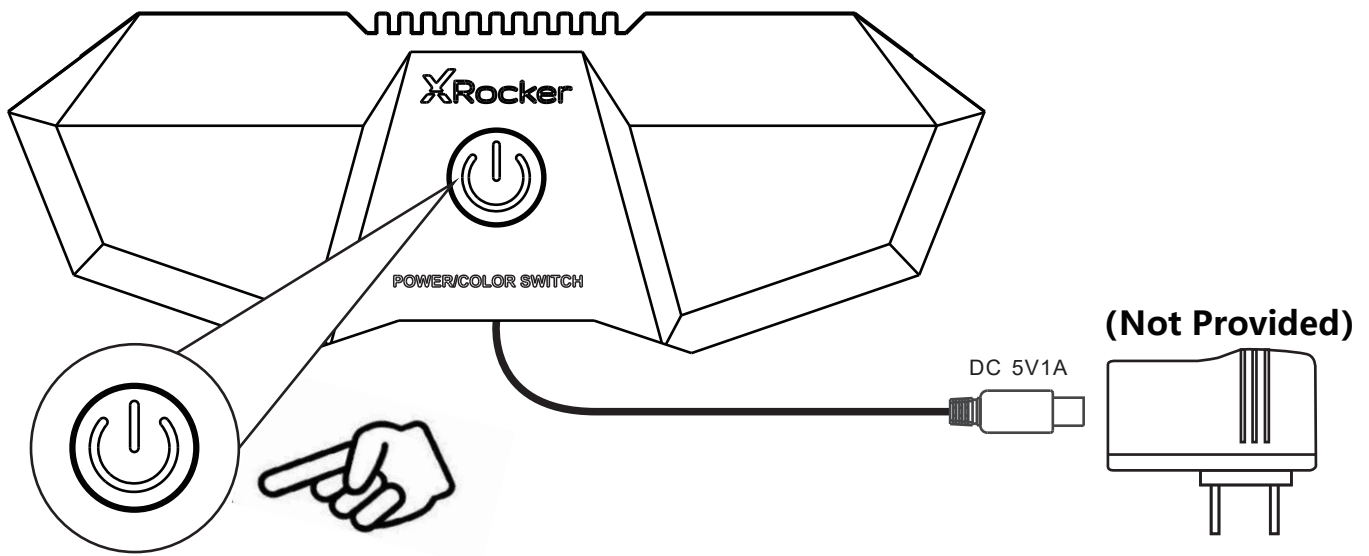

1. Press and hold the standby button to turn on the control panel.
2. Press the standby button to toggle between the different color modes.
3. Press and hold the standby button to turn off the control panel.

Remote control function introduction

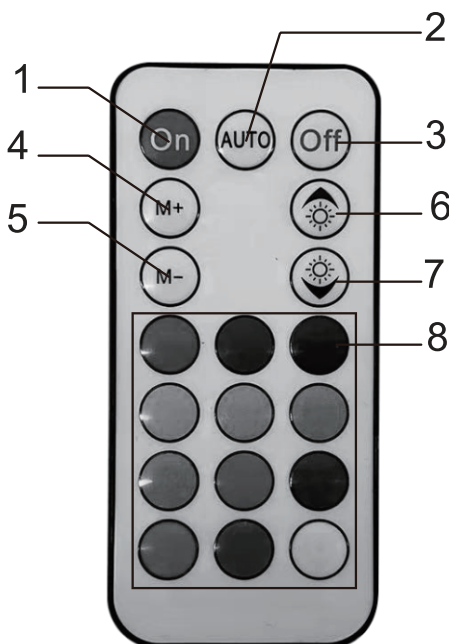

1. Light On
2. Light Auto
3. Light Off
4. Light Mode+
5. Light Mode-
6. Increase Brightness
7. Decerase Brightness
8. Light Color Selection

