

56985

CORONA BUDGET DINING CHAIR ASSEMBLY INSTRUCTIONS

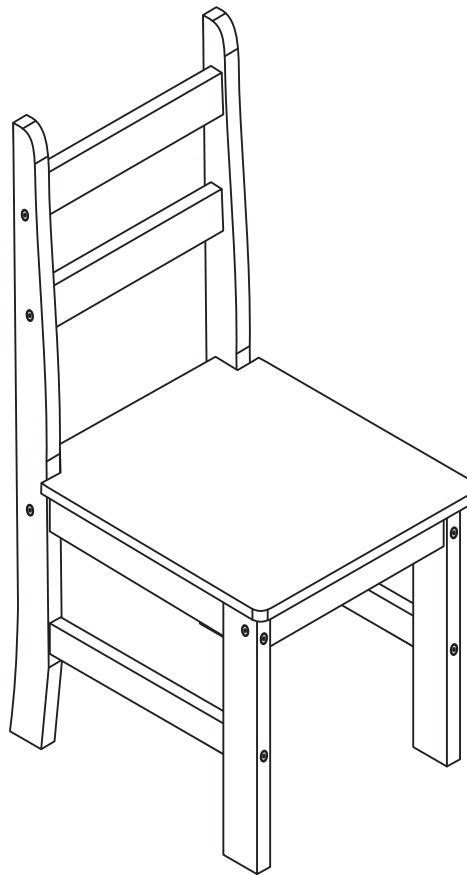

IMPORTANT FOR DOMESTIC USE ONLY PLEASE READ BEFORE YOU CONTINUE FURTHER CARE AND MAINTENANCE

After unpacking this product please keep the original packaging in case it needs to be returned for any reason.



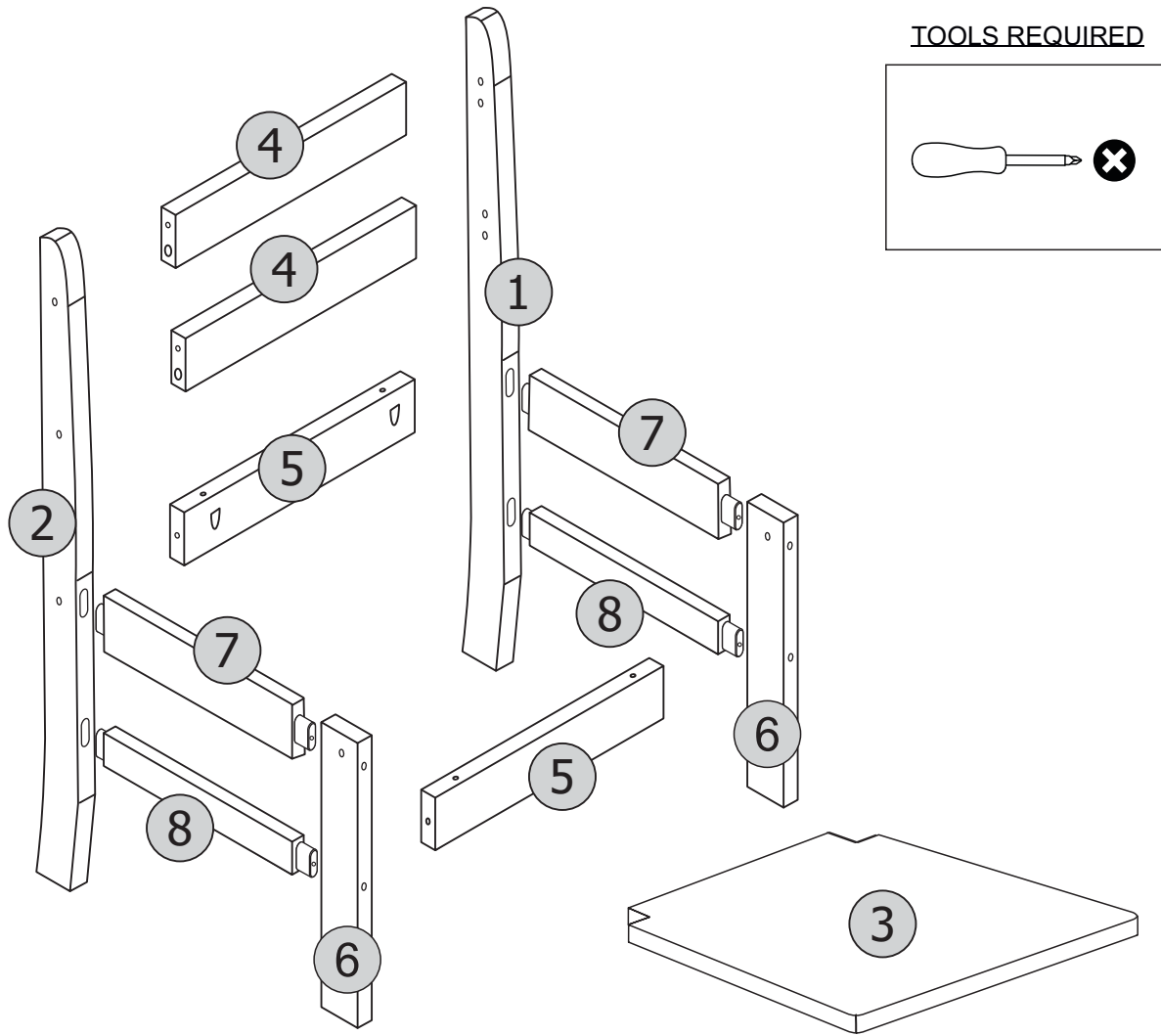

- Please ensure all fittings and parts are present before commencing with assembly.
- We recommend that you lay a blanket or sheet on the floor to avoid damage to both your floor and the product.
- We strongly recommend that you keep children away from your work area.
- Assemble this product as close to its final position as possible.
- Never drag or push products as this could cause damage to the joints making it inferior.
- Do not place this product next to a radiator or in direct sunlight.
- Wood is a natural product and may expand if subjected to damp and may shrink or crack if subjected to heat. Therefore it is recommended that room temperature is maintained, with no sudden temperature fluctuations.
- Make sure any spillage is wiped off immediately.
- Do not place hot or chilled items directly on to the surface, use a place mat or marking will occur.
- For general cleaning use a duster, and do not use detergents of any kind. However, the surface will need to be retreated from time to time. This can be done by using block wax (unperfumed) and rubbing it over the whole item.
- From time to time it may be necessary to tighten fittings, regular inspections should be carried out.



PARTS LIST (PER CHAIR)

Part Number	Part Code	Part Description	Quantity	Carton
1	S400-401-152-DC1-01C	Right Chair Side	1	1/1
2	S400-401-152-DC1-02C	Left Chair Side	1	1/1
3	S400-402-152-DC1-03C	Seat Pad	1	1/1
4	S400-402-152-DC1-04C	Back Rail	2	1/1
5	S400-402-152-DC1-05C	Seat Rail	2	1/1
6	S400-402-152-DC1-06C	Front Leg	2	1/1
7	S400-402-152-DC1-07C	Side Seat Rail	2	1/1
8	S400-402-152-DC1-08C	Stretcher	2	1/1

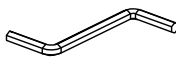
HARDWARE LIST

A	 GLUE	01	D	 Ø7,0x60mm (Black)	08
B	 8,0 x 30mm	04	E		01
C	 Ø4,0 x 35mm	04	F	 Ø7,0x70mm (Black)	08

STEP 1

PARTS REQUIRED

1 - RIGHT CHAIR SIDE	x1
2 - LEFT CHAIR SIDE	x1
6 - FRONT LEG	x2
7 - SIDE SEAT RAIL	x2
8 - STRETCHER	x2

HARDWARE REQUIRED

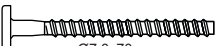
A	GLUE	01
F	 Ø7,0x70mm	08

TOOLS REQUIRED

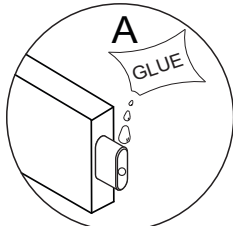
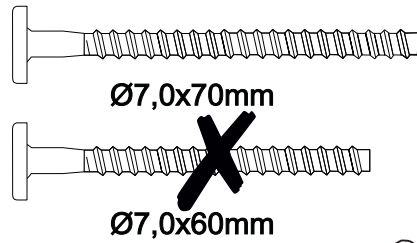

Detail 1

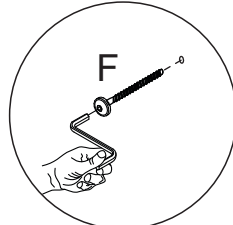

Detail 2

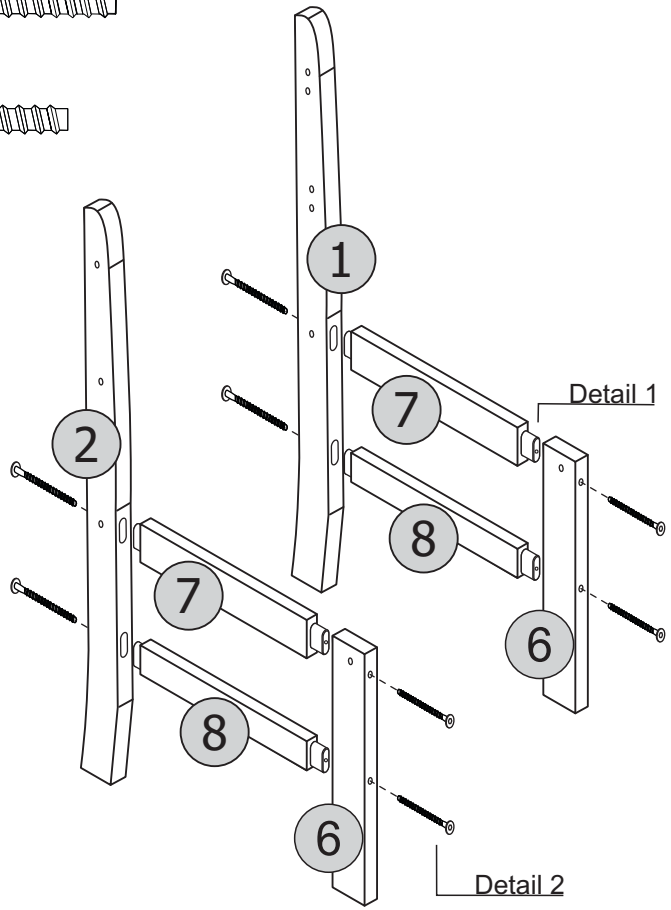

Detail 1

Detail 2

STEP 2

PARTS REQUIRED

4 - BACK RAIL	x2
---------------	----

HARDWARE REQUIRED

A	GLUE	01
B	 Ø8x30mm	04

TOOLS REQUIRED

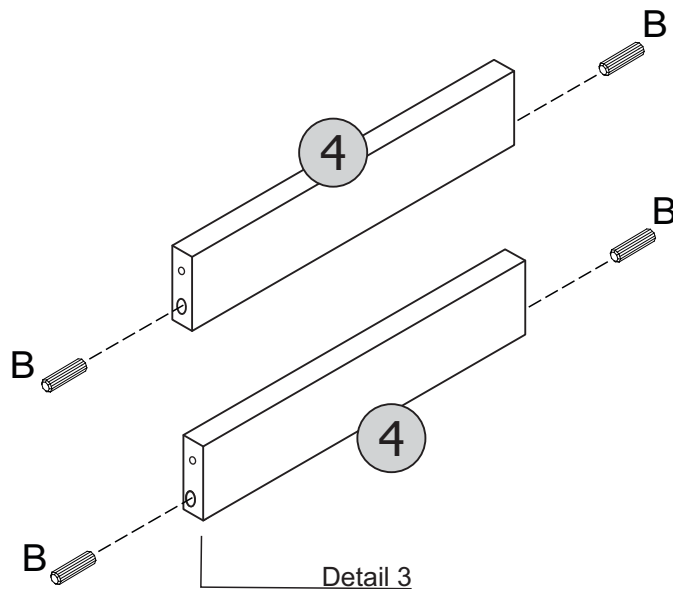

Detail 3

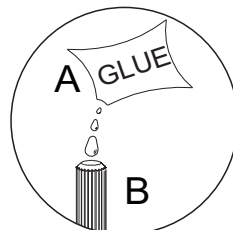

Detail 3

STEP 3

PARTS REQUIRED

- 4 - BACK RAIL x2
- 5 - SEAT RAIL x2

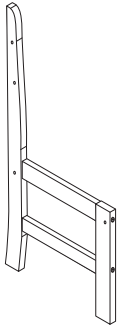

HARDWARE REQUIRED

- A GLUE 01
- D Ø7,0x60mm 04

TOOLS REQUIRED

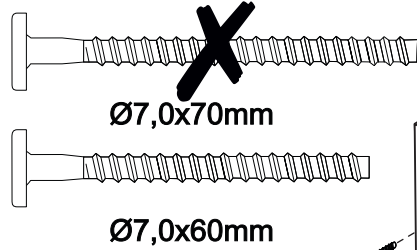

Detail 4

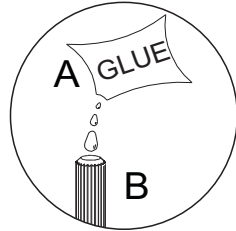

Detail 3

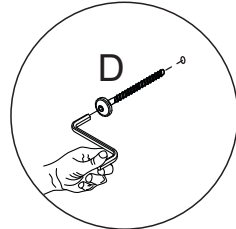

Detail 4

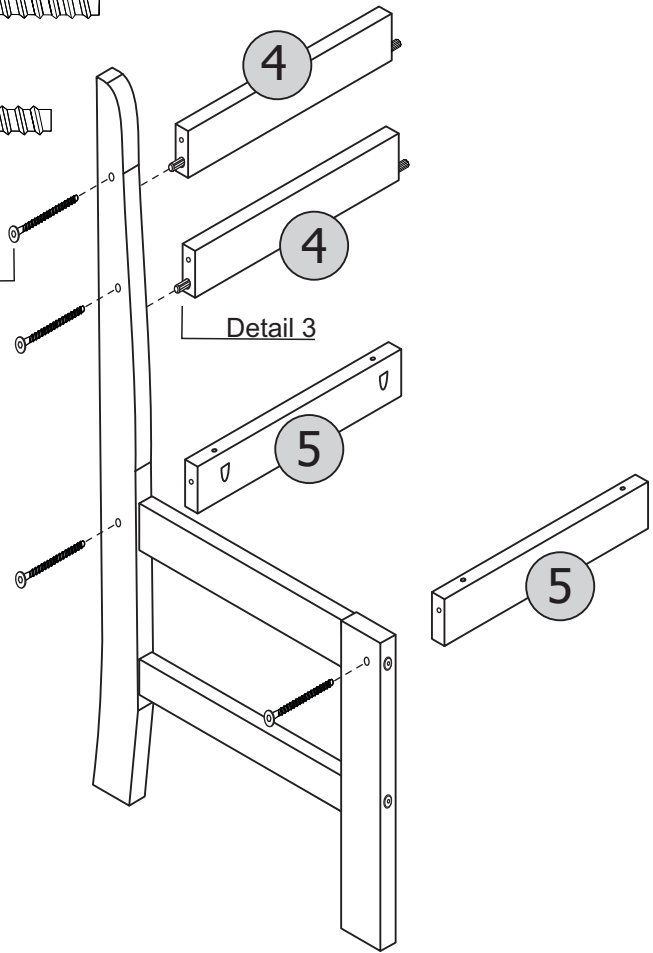

STEP 4

PARTS REQUIRED

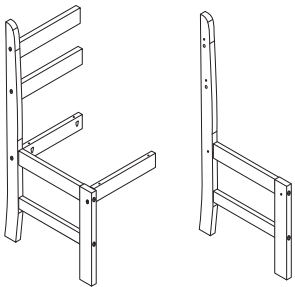

HARDWARE REQUIRED

- A GLUE 01
- D Ø7,0x60mm 04

TOOLS REQUIRED

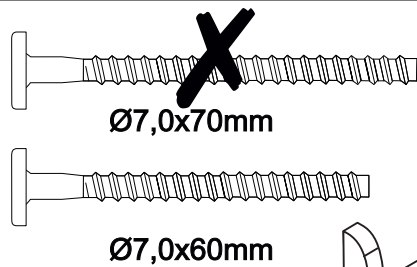

Detail 3

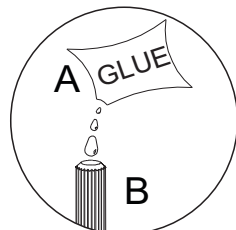

Detail 3

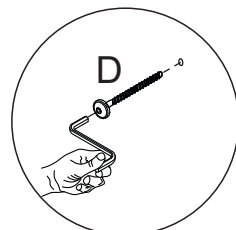

Detail 4

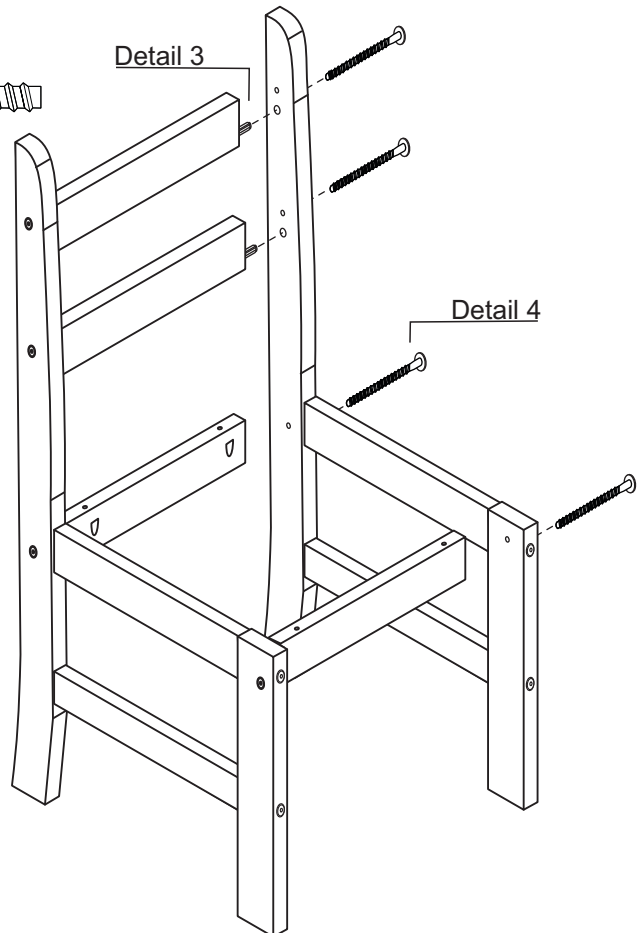

STEP 5

PARTS REQUIRED

3 - SEAT PAD x1

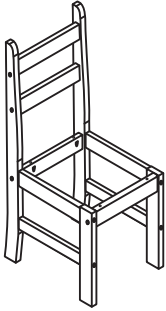

HARDWARE REQUIRED

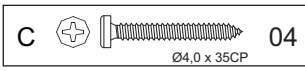

TOOLS REQUIRED

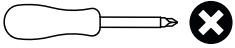

FOR YOUR FUTURE
REFERENCE
ORDER NUMBER
SHOULD BE HERE

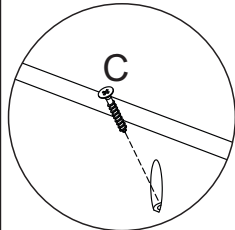

Detail 5

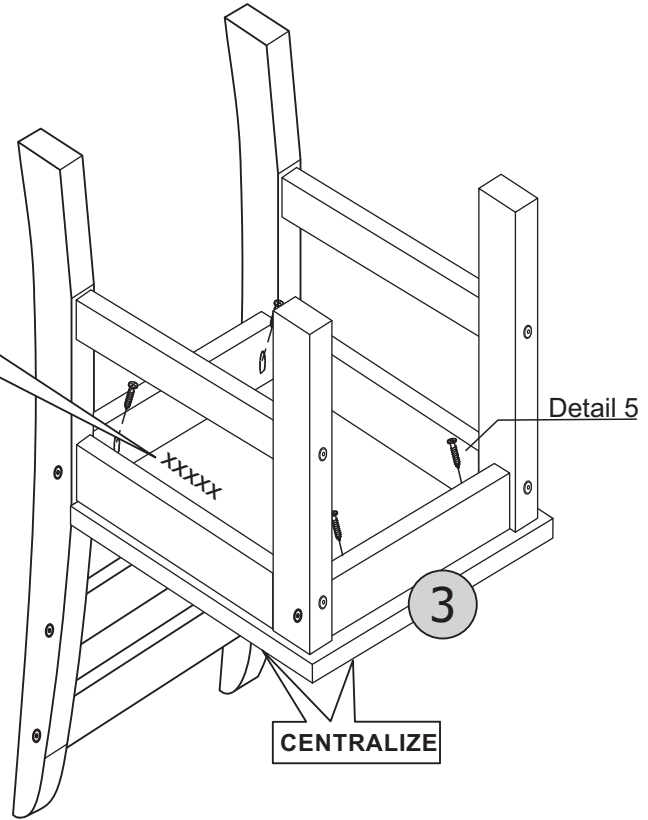

STEP 6

PARTS REQUIRED

HARDWARE REQUIRED

TOOLS REQUIRED

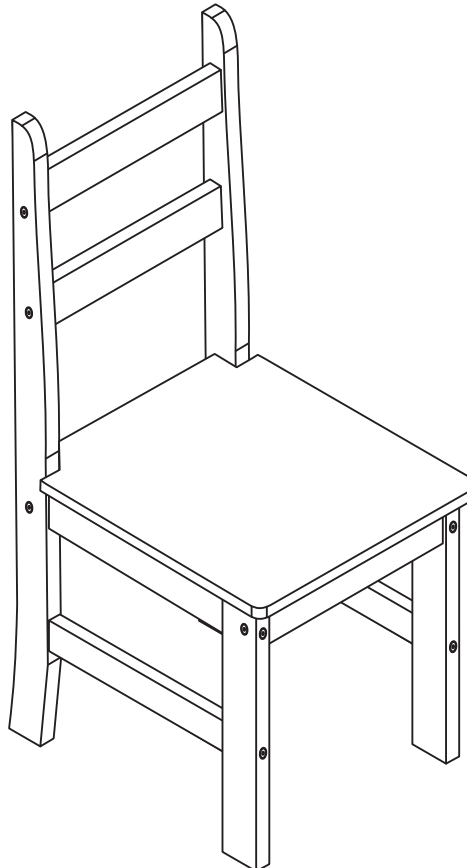

56985

CORONA BUDGET DINING TABLE ASSEMBLY INSTRUCTIONS

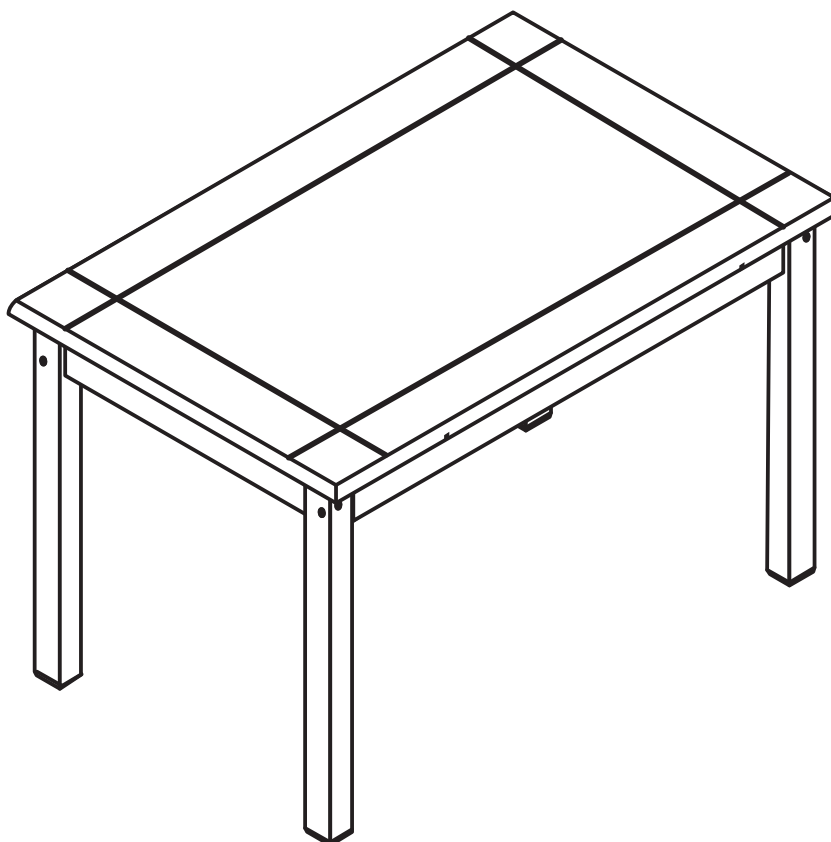

IMPORTANT

**PLEASE READ BEFORE YOU CONTINUE FURTHER
FOR DOMESTIC USE ONLY**

CARE AND MAINTENANCE

After unpacking this product please keep the original packaging in case it needs to be returned for any reason.

- Please ensure all fittings and parts are present before commencing with assembly.
- We recommend that you lay a blanket or sheet on the floor to avoid damage to both your floor and the product.
- We strongly recommend that you keep children away from your work area.
- Assemble this product as close to its final position as possible.
- Never drag or push products as this could cause damage to the joints making it inferior.
- Do not place this product next to a radiator or in direct sunlight.
- Wood is a natural product and may expand if subjected to damp and may shrink or crack if subjected to heat. Therefore it is recommended that room temperature is maintained, with no sudden temperature fluctuations.
- Make sure any spillage is wiped off immediately.
- Do not place hot or chilled items directly on to the surface, use a place mat or marking will occur.
- For general cleaning use a duster, and do not use detergents of any kind. However, the surface will need to be retreated from time to time. This can be done by using block wax (unperfumed) and rubbing it over the whole item.
- From time to time it may be necessary to tighten fittings, regular inspections should be carried out.

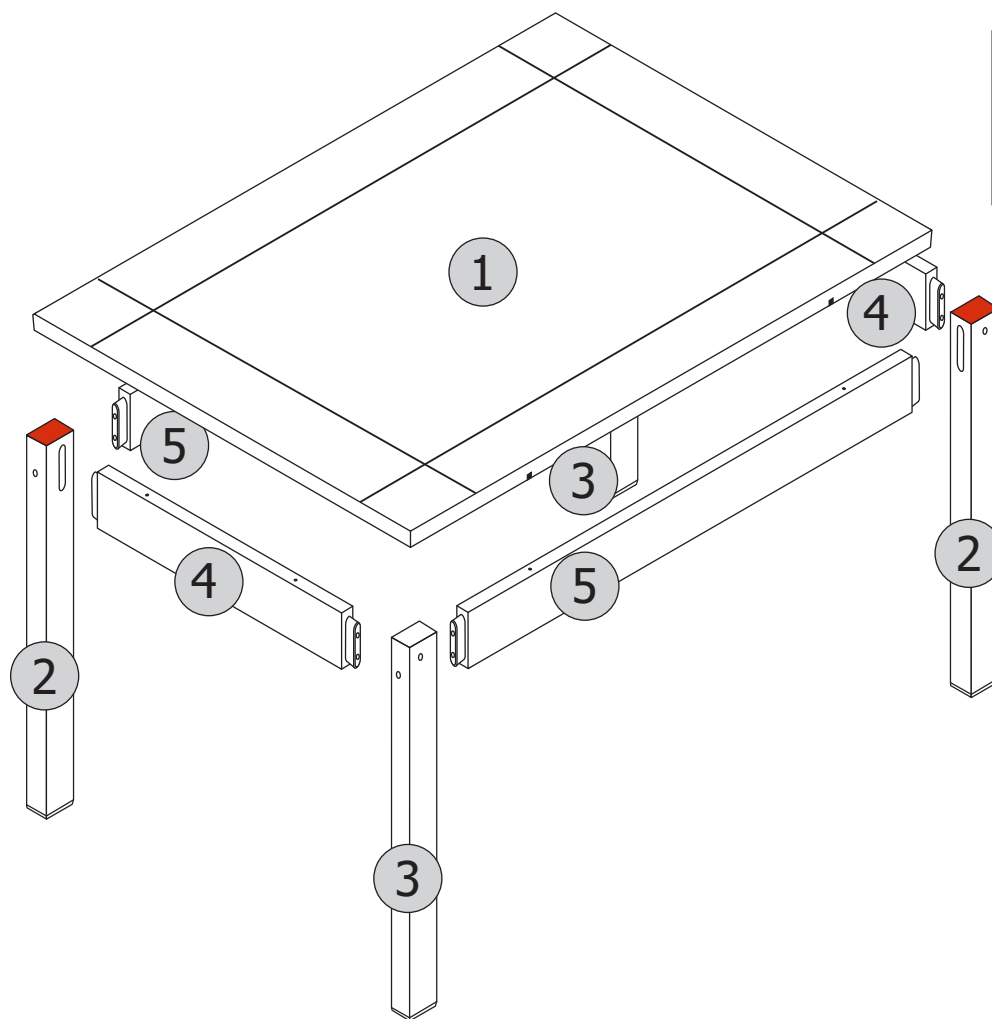

TOOLS REQUIRED

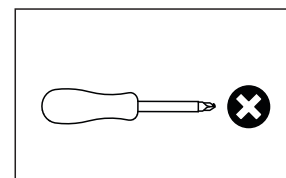





Please Note:
The below parts have been number/colour coded to help identify them during assembly.

PARTS LIST

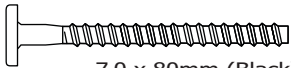
Part Number	Part Code	Part Description	Quantity	Carton
1	S400-401-152-DC1-01T	Table Top	1	1/1
2	S400-401-152-DC1-02T	Table Leg (Red Marking)	2	1/1
3	S400-401-152-DC1-03T	Table Leg	2	1/1
4	S400-401-152-DC1-04T	Short Frame Side	2	1/1
5	S400-401-152-DC1-05T	Long Frame Side	2	1/1

HARDWARE LIST

A	 GLUE	01	C	 7,0 x 80mm (Black)	04	E	 7,0 x 60mm (Black)	04
B	 Ø4,0 x 35CP	10	D		01			

STEP 1

PARTS REQUIRED

2 - TABLE LEG (RED) x1

3 - TABLE LEG x1

5 - LONG FRAME SIDE x1

HARDWARE REQUIRED

A  01

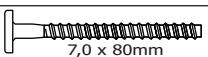
C  02
7,0 x 80mm

TOOLS REQUIRED

D  01



Ø7,0x80mm



Ø7,0x60mm

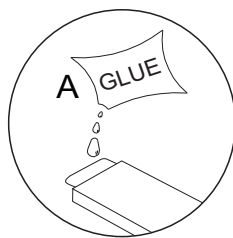
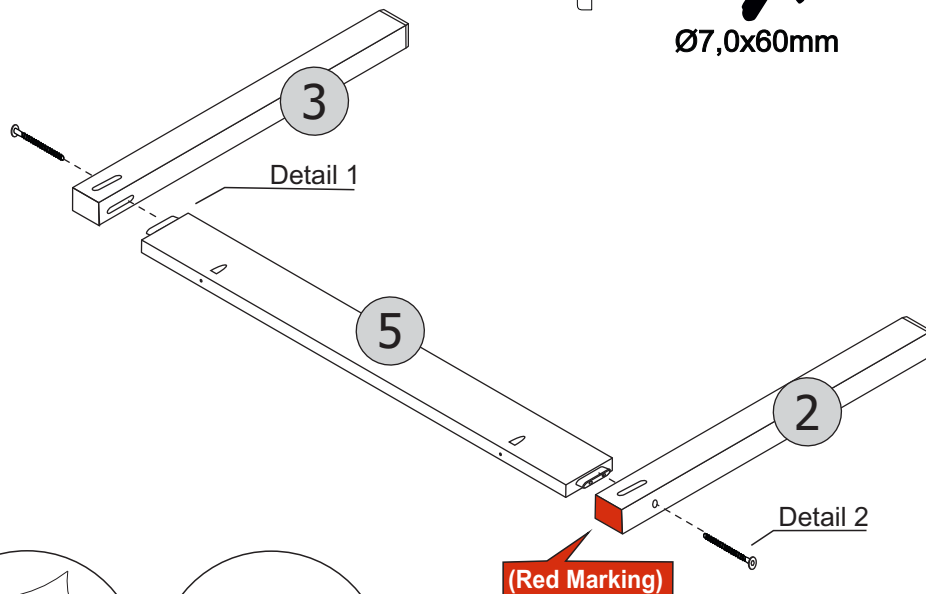

Detail 1

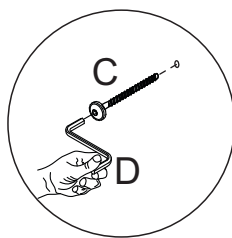

Detail 2

STEP 2

PARTS REQUIRED

2 - TABLE LEG (RED) x1

3 - TABLE LEG x1

5 - LONG FRAME SIDE x1

HARDWARE REQUIRED

A  01

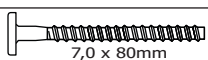
C  02
7,0 x 80mm

TOOLS REQUIRED

D  01



Ø7,0x80mm



Ø7,0x60mm

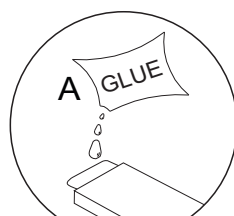
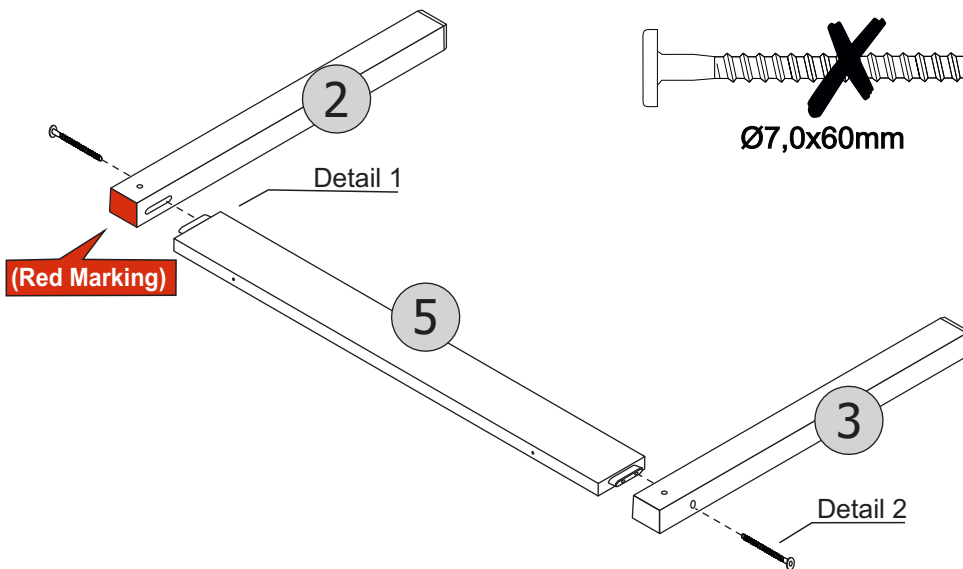

Detail 1

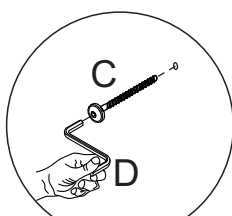

Detail 2

STEP 3

PARTS REQUIRED

4 - SHORT FRAME SIDE x2

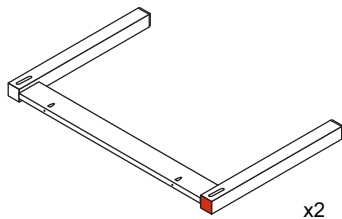

HARDWARE REQUIRED

A  01

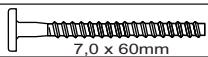
E  04
7,0 x 60mm

TOOLS REQUIRED

D  01



Ø7,0x80mm

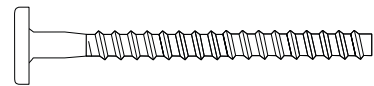

Ø7,0x60mm

(Red Marking)

4

Detail 1

4

Detail 2

(Red Marking)

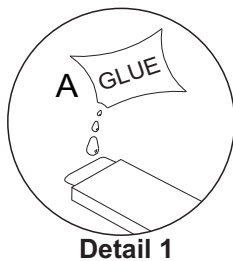

Detail 1

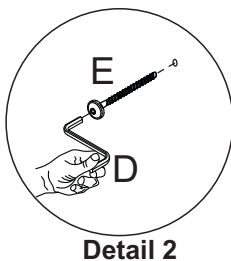

Detail 2

STEP 4

PARTS REQUIRED

1 - TABLE TOP x1

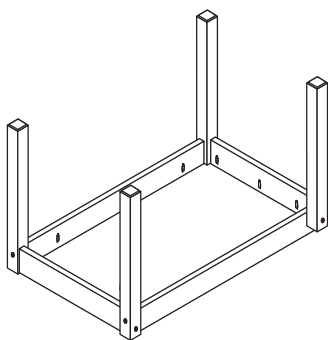

HARDWARE REQUIRED

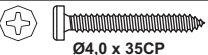
B  10
Ø4,0 x 35CP

TOOLS REQUIRED

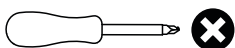

FOR YOUR FUTURE
REFERENCE
ORDER NUMBER
SHOULD BE HERE

Detail 3

CENTRALIZE

XXXXXXXX

1

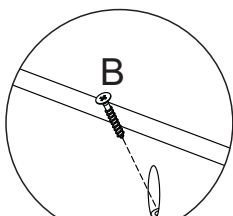

Detail 3